

KIT FEATURES

- ▶ ISO head unit provisions



99-7310

INSTALLATION INSTRUCTIONS

KIT COMPONENTS

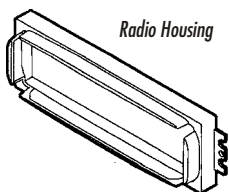

Radio Housing

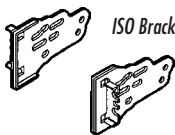

ISO Brackets



(4) #10 x 3/4" Phillips Pan-head Screws

APPLICATIONS

CAR

PAGE

HYUNDAI

Accent 2000-01.....1-2



TOOLS REQUIRED



Phillips screwdriver



1-800-221-0932



www.metraonline.com

© COPYRIGHT 2001 METRA ELECTRONICS CORPORATION

rev. 240701

ALL VEHICLES

1

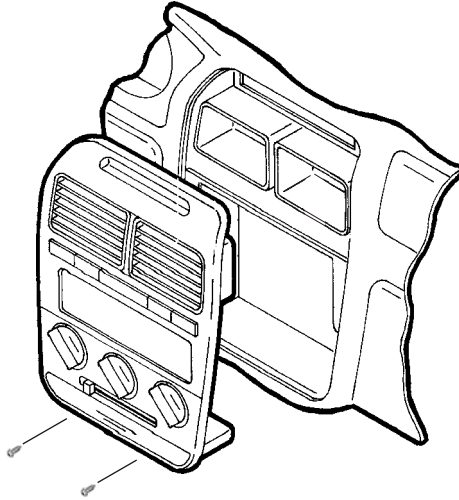

Disconnect the negative battery terminal to prevent an accidental short circuit. Open the cupholder and remove (2) Phillips screws exposed. Lower the glove box and detach the vent cable exposed. Reach under the driver's side dash and detach (2) vent cables located above the accelerator. Unclip the dash trim bezel and remove. Remove (4) screws securing the factory head unit and disconnect the wiring.

2

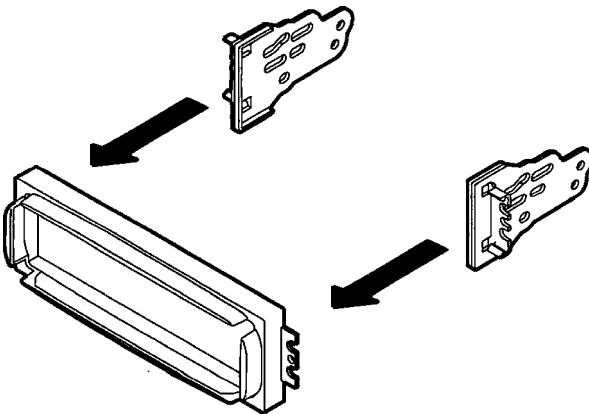

Snap the **ISO Brackets** over the mounting tabs on the **Radio Housing**.

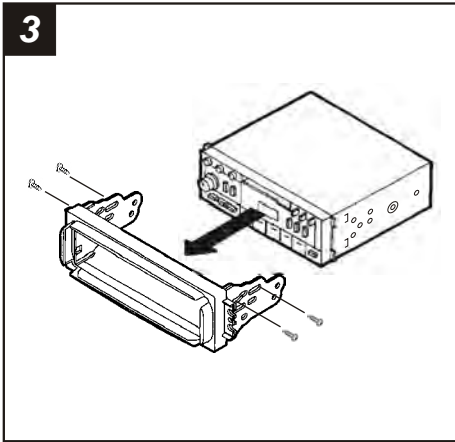

Slide the head unit into the **Radio Housing**, align the holes in the head unit with the holes in the Housing and mount the unit with the screws supplied with the unit.

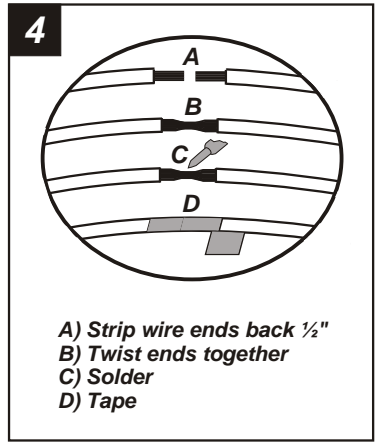

Locate the factory wiring harness in the dash. Metra recommends using the proper mating adaptor and making connections as shown. (Isolate and individually tape off the ends of any unused wires to prevent electrical short circuit).

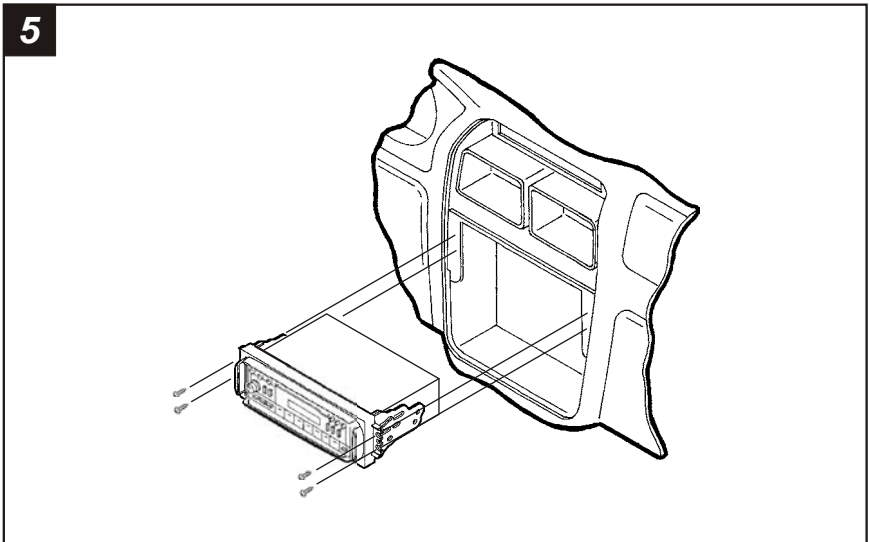

Re-connect the battery terminal and test the unit for proper operation. Mount the head unit/kit assembly to the sub-dash with (4) Phillips screws previously removed in step #1.