

KIT FEATURES

- ▶ ISO head unit provisions
- ▶ CD jewel case pocket (holds 2 jewel cases)



99-7311 INSTALLATION INSTRUCTIONS

KIT COMPONENTS

Radio Housing

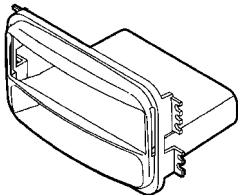

ISO Brackets

(2) #10 x 3/4" Phillips
Pan-head Screws



APPLICATIONS

CAR

HYUNDAI

Sonata 1999-01.....1-2

PAGE



TOOLS REQUIRED



Phillips screwdriver



1-800-221-0932



www.metraonline.com

© COPYRIGHT 2001 METRA ELECTRONICS CORPORATION

rev. 240701

ALL VEHICLES

1

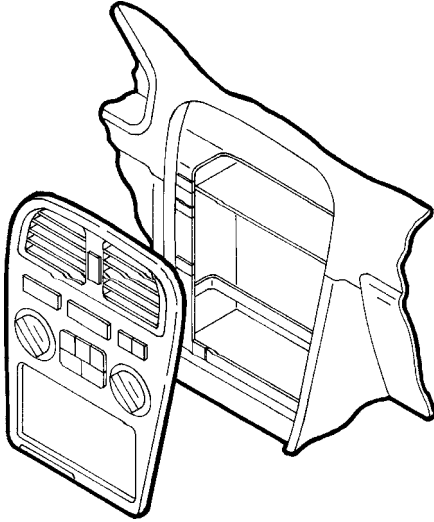

Disconnect the negative battery terminal to prevent an accidental short circuit. Detach the cable located under the left side of the glove box. Unclip the trim piece in front of the gear shifter and remove (2) Phillips screws exposed. Unclip the gear shifter trim and remove (2) Phillips screws exposed. Unclip the radio trim bezel and remove. Remove (6) Phillips screws securing the factory head unit and disconnect the wiring.

2

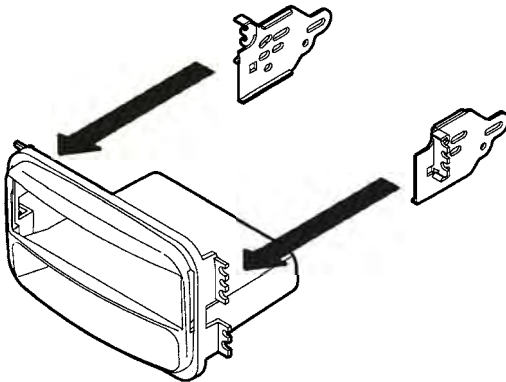

Snap the **ISO Brackets** over the mounting tabs on the **Radio Housing**.

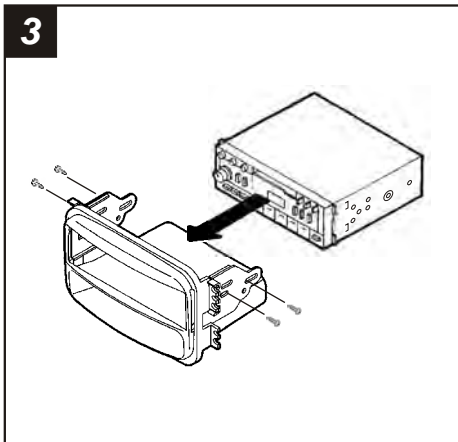

Slide the head unit into the **Radio Housing**, align the holes in the head unit with the holes in the Housing and mount the unit with the screws supplied with the unit.

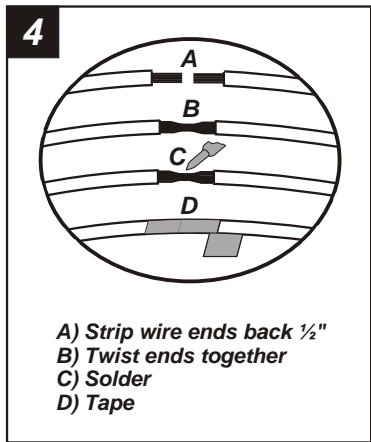

- A) Strip wire ends back ½"**
- B) Twist ends together**
- C) Solder**
- D) Tape**

Locate the factory wiring harness in the dash. Metra recommends using the proper mating adaptor and making connections as shown. (Isolate and individually tape off the ends of any unused wires to prevent electrical short circuit).

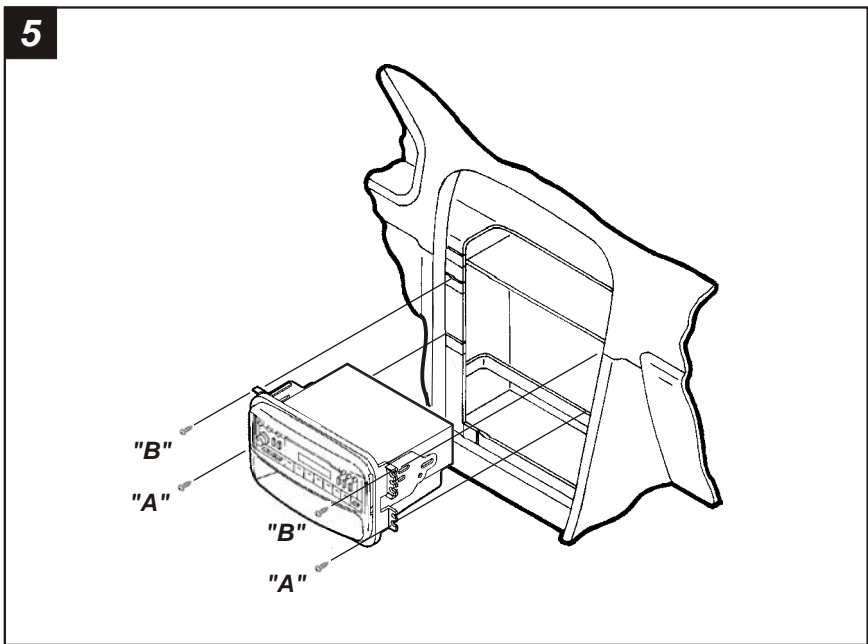

Re-connect the battery terminal and test the unit for proper operation. Mount the head unit/kit assembly to the sub-dash with (2) Phillips screws previously removed in step #1 ("A") and (2) **#10 x ¾" Phillips Pan-head Screws** supplied ("B").