

KIT FEATURES

- ▶ DIN head unit provisions
- ▶ Pocket



99-7314

INSTALLATION INSTRUCTIONS

KIT COMPONENTS

Radio Housing

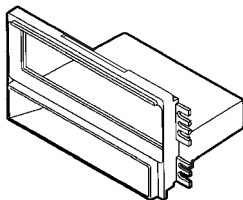

APPLICATIONS

CAR

PAGE

KIA

Optima 2001-06.5.....	1-2
Sonata 2002.....	1-2



TOOLS REQUIRED



Phillips screwdriver



1-800-221-0932



www.metraonline.com

© COPYRIGHT 2001-07 METRA ELECTRONICS CORPORATION

rev. 06-15-07

ALL VEHICLES

1

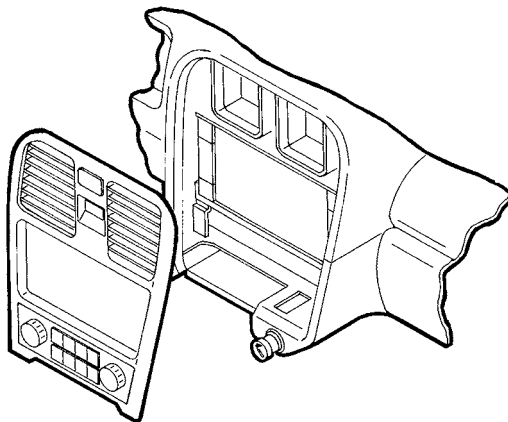

Disconnect the negative battery terminal to prevent an accidental short circuit. Unclip the dash trim bezel. Disconnect the clock and climate control wiring and remove the bezel. Remove (4) Phillips screws securing the factory head unit and disconnect the wiring.

2

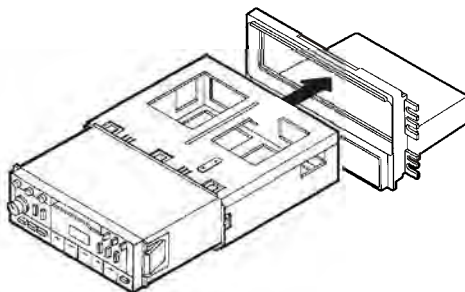

Slide the DIN cage into the Radio Housing and secure by bending the metal locking tabs down. Slide the aftermarket head unit into the cage until secure.

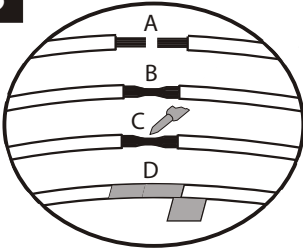
3

- A) Strip wire ends back ½"
- B) Twist ends together
- C) Solder
- D) Tape

Locate the factory wiring harness in the dash. Metra recommends using the proper mating adaptor and making connections as shown. (Isolate and individually tape off the ends of any unused wires to prevent electrical short circuit).

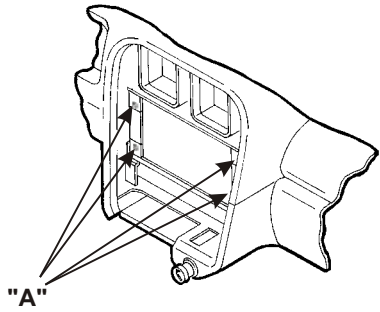
4

Locate the (4) mounting positions in the sub-dash ("A").

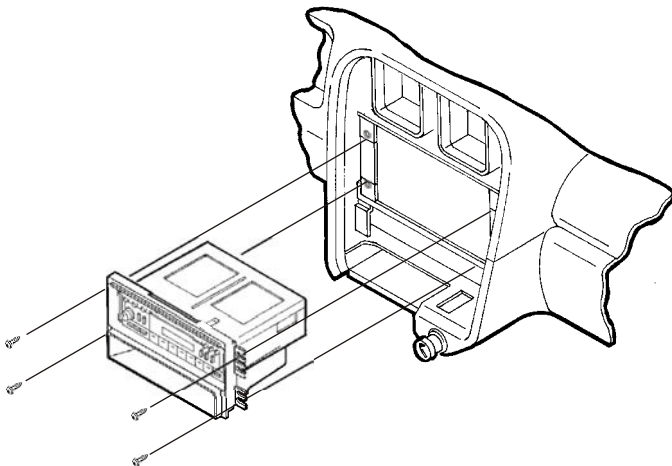
5

Re-connect the battery terminal and test the unit for proper operation. Mount the head unit/kit assembly to the sub-dash with (4) Phillips screws previously removed in step #1.