



INSTALLATION INSTRUCTIONS FOR PART 99-7319

APPLICATIONS 2004-2006 Kia Amanti

99-7319

KIT FEATURES

- DIN Head Unit Provision
- ISO DIN Head Unit Provision



KIT COMPONENTS

A) Radio Housing B) A/C Control Brackets C) ISO Brackets D) Trim plate

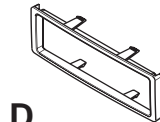
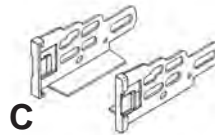
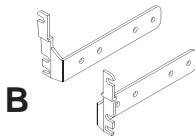
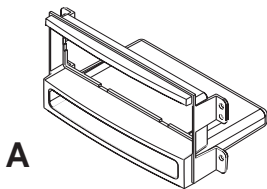

TOOLS REQUIRED:

Phillips Screwdriver | Small Flat Blade Screwdriver

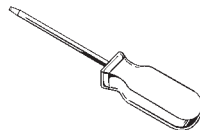
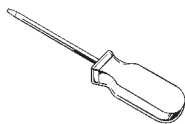

1-800-221-0932



www.metraonline.com

© COPYRIGHT 2004-07 METRA ELECTRONICS CORPORATION



TABLE OF CONTENTS

***Dash Disassembly** 1, 2*

***Kit Assembly** 3, 4*

***Final Assembly** 5*

2004-2006 KIA AMANTI

- 1** Disconnect the negative battery terminal to prevent an accidental short circuit.
- 2** Unclip and remove panel surrounding shifter including cup holders. (Figure A)
- 3** Remove (2) Phillips screws at base of panel surrounding radio and a/c controls. (Figure B)
- 4** Unclip and remove panel surrounding radio and a/c control. (Figure C)

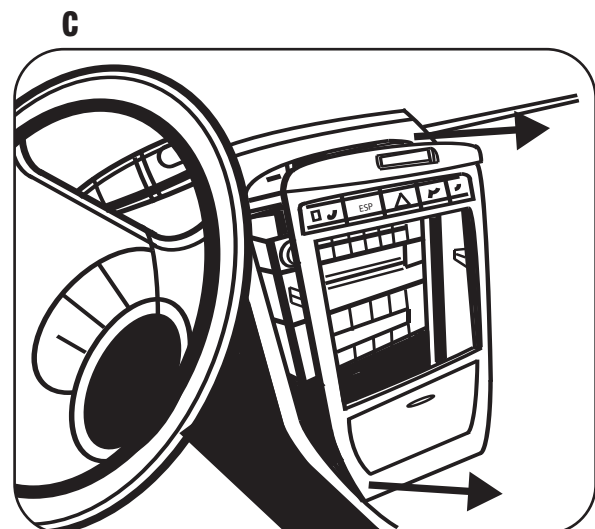
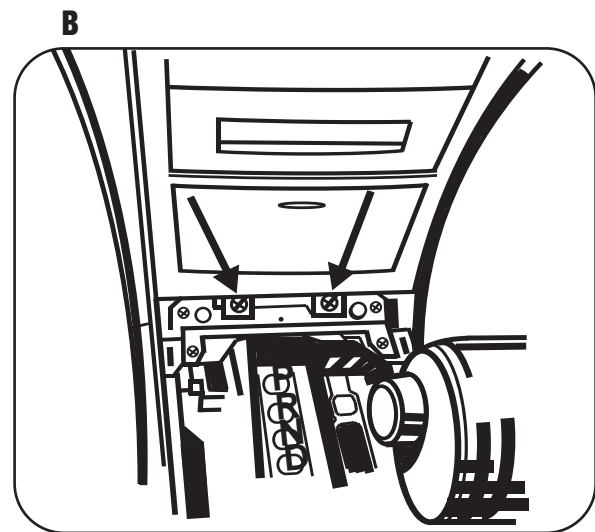
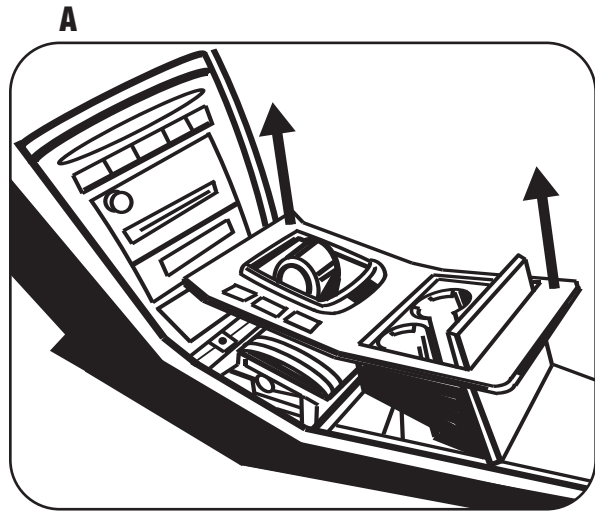

2004-2006 KIA AMANTI

- 5 Remove (6) Phillips screws securing radio and a/c control. (Figure D)
- 6 Remove (4) Phillips screws securing factory a/c control to bracket assembly. (Figure E)

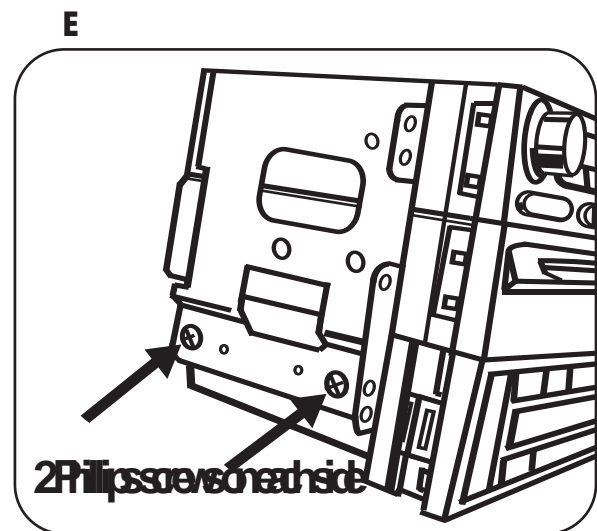
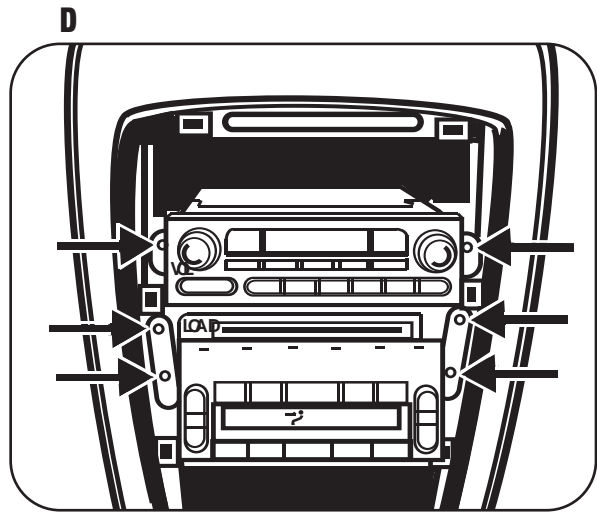

2004-2006 KIA AMANTI DIN HEAD UNIT PROVISION

- 1 Attach the corresponding a/c control bracket to the factory a/c control using the factory hardware. (Figure A)

Note: The radio housing must be installed first before the a/c control.

- 1 Slide the DIN cage into the radio housing and secure by bending the metal locking tabs down. (Figure B)
- 2 Slide the aftermarket head unit into the cage and secure. (Figure C)

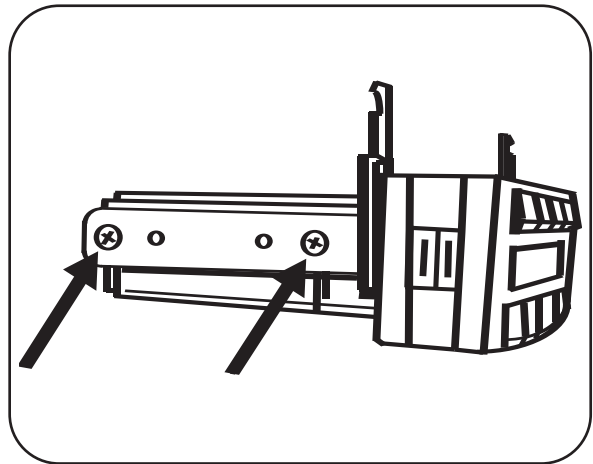
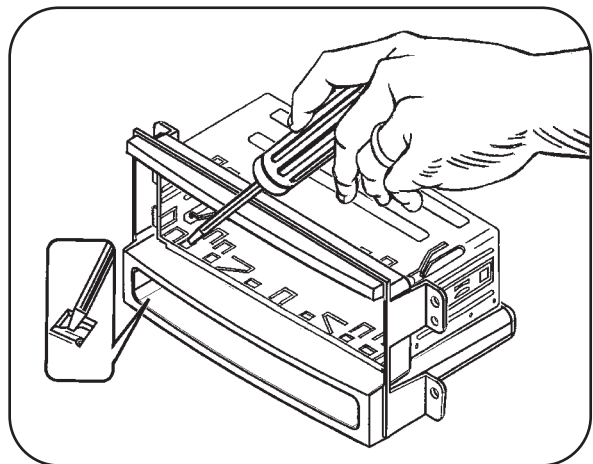
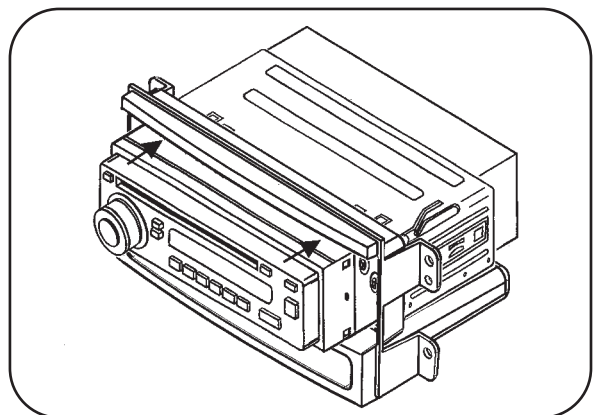
A

B

C

2004-2006 KIA AMANTI

ISO DIN HEAD UNIT PROVISION

- 1 Attach the corresponding a/c control bracket to the factory a/c control using the factory hardware. (Figure A)

Note: *The radio housing must be installed first before the a/c control.*

A

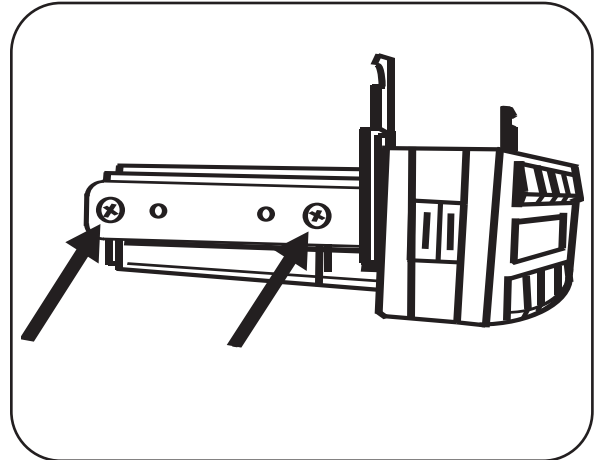

- 1 Mount the ISO bracket to the head unit with screws supplied with the unit. (Figure B)

B

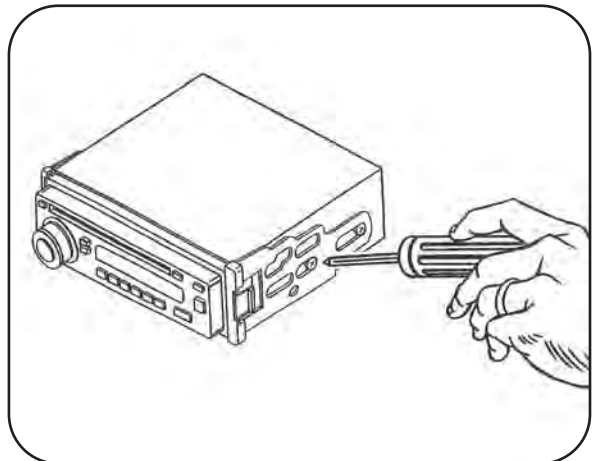

- 2 Slide the head unit into the radio opening until the side clips engage. (Figure C)

- 3 Snap the trim plate into the radio housing. (Figure C)

C

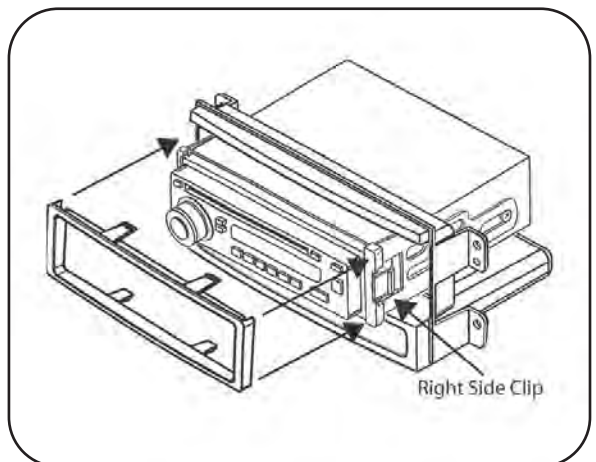

FINAL ASSEMBLY

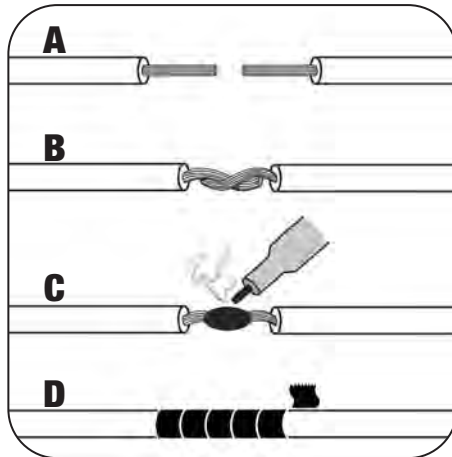

- A) Strip wire ends back 1/2"**
- B) Twist ends together**
- C) Solder**
- D) Tape**

- 1** Locate the factory wiring harness in the dash. Metra recommends using the proper mating adapter and making connections as shown. (Isolate and individually tape off the ends of any unused wires to prevent electrical short circuit.)
- 2** Re-connect the negative battery terminal and test the unit for proper operation.
- 3** Reassemble radio and dash assemblies in reverse order of disassembly installing the radio housing first and then the a/c control.

FINAL WIRING CONNECTIONS

Make wiring connections using the EIA color code chart shown below and the instructions included with the head unit. Metra recommends making connections as shown below; Strip, Splice, Solder, Tape. Isolate and individually tape off ends of any unused wires to prevent electrical short circuit.

METRA / EIA WIRING CODE

12V Ignition / Acc . . . Red	Right Front (+) Gray
12V Batt / Memory . . Yellow	Right Front (-) Gray / Black
Ground Black*	Left Front (+) White
Power Antenna Blue	Left Front (-) White / Black
Amp Turn-On Blue / White	Right Rear (+) Violet
Amp Ground Black / White	Right Rear (-) Violet / Black
Illumination Orange	Left Rear (+) Green
Dimmer Orange / White	Left Rear (-) Green / Black

***NOTE:** When Black a wire is not present, ground radio to vehicle chassis.
All colors may not be present on all leads due to manufacturer's specifications.

99-7319 INSTRUCTIONS



1-800-221-0932



www.metraonline.com

REV. 06/19/2007

© COPYRIGHT 2004-07 METRA ELECTRONICS CORPORATION

INST99-7319