



INSTALLATION INSTRUCTIONS FOR PART 99-7406

APPLICATIONS Nissan Titan 2004-2005

Nissan Titan (Without Dual Zone
Climate Controls) 2006-2007

Nissan Pathfinder Armada 2004-2005

99-7406



KIT FEATURES

- DIN Head Unit Provisions with Pocket
- ISO DIN Head Unit Provisions with Pocket

KIT COMPONENTS

- A) Radio Housing
- B) Radio Housing Trim Panel
- C) ISO Brackets
- D) Trim Plate
- E) (6) PPH-38 Screws
- F) (6) Panel Clips
- G) Two Sided Tape (Not Shown)

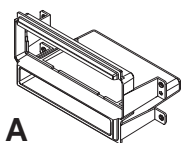

A

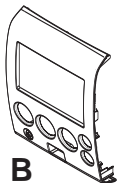

B

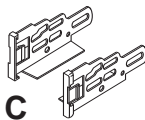

C



D



E



F

TOOLS REQUIRED:

- Torx T-10 Driver
- Small Flat Blade Screwdriver/ Panel Removal Tool
- Phillips Screwdriver



1-800-221-0932



www.metraonline.com

© COPYRIGHT 2004-2008 METRA ELECTRONICS CORPORATION

TABLE OF CONTENTS

Dash Disassembly

- Nissan Titan 2004-2007..... 1,2**
- Pathfinder Armada 2004-20051,2**

Kit Assembly

- Pre-Kit Assembly..... 3**
- DIN Head Unit Provision4**
- ISO Din Head Units Provision..... 5**

***Note:**

Refer also to the instructions included with the aftermarket radio.

Nissan Titan 2004-2007
Nissan Pathfinder Armada 2004-2005

- 1** Disconnect the negative battery terminal to prevent an accidental short circuit.
 - 2** Unclip and remove entire panel including the radio and climate controls. (Figure A)
 - 3** Remove (4) Phillips screws to remove radio from sub-dash. (Figure B)
 - 4** Unsnap and remove the outer trim rings around a/c control knobs. (Figure C)
- NOTE:** The small round Airbag sticker also needs to be removed from the factory panel and placed onto the 99-7406 radio housing panel. (A round piece of double-sided tape is provided in case the factory sticker is not strong enough.) (Figure C)

Continue to kit assembly.

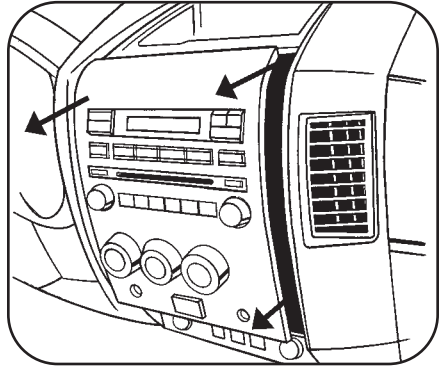
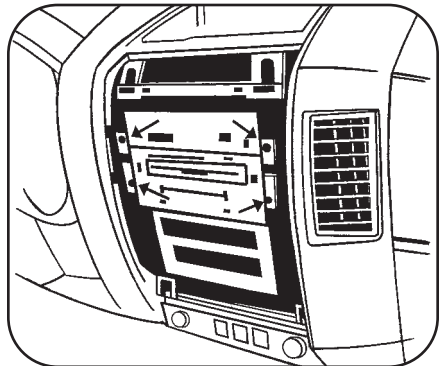
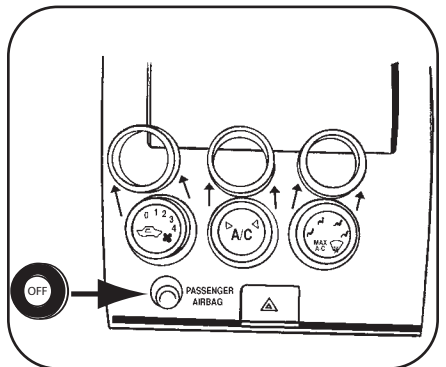
A

B

C

Nissan Titan 2004-2007
Nissan Pathfinder Armada 2004-2005

5 Remove (4) T-10 Torx screws from the a/c controls to remove from the factory radio trim panel. (Figure D)

6 Unclip and remove the Hazard Light switch assembly. (Figure D)

7 Remove (2) T10 Torx screws from the passenger air bag off light assembly and remove. (Figure D)

NOTE: *The small round sticker also needs to be removed from the factory panel and placed onto the 99-7406 radio housing trim panel.*

Continue to pre-kit assembly.

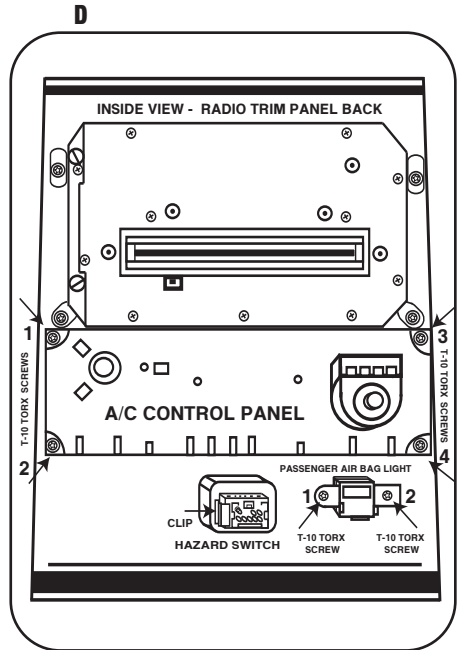

Nissan Titan 2004-2007
Nissan Pathfinder Armada 2004-2005

- 1** Attach the a/c control to the 99-7406 Radio Housing Trim Panel using the supplied (4) Phillips PPH-38 screws. (Figure A)
- 2** Snap the outer trim rings onto the a/c control knobs. (Figure B)
- 3** Attach the passenger air bag off light assembly to the 99-7406 Radio Housing Trim Panel using the supplied (2) Phillips PPH-38 screws. Also, apply to air bag button the small round airbag sticker previously removed in Step 4 dash disassembly. (Figure C)
- 4** Snap the hazard light switch into the 99-7406 Radio Housing Trim Panel. (Figure D)
- 5** Attach the (6) panel clips to the 99-7406 radio housing panel using the factory radio panel as a reference for clip positioning.

Continue to kit assembly.

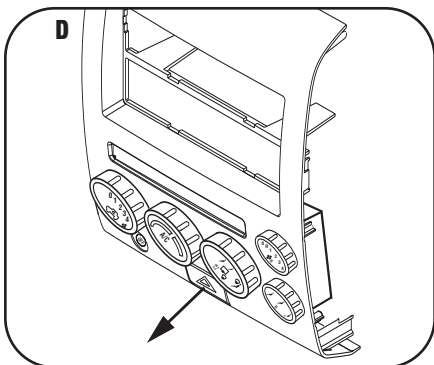
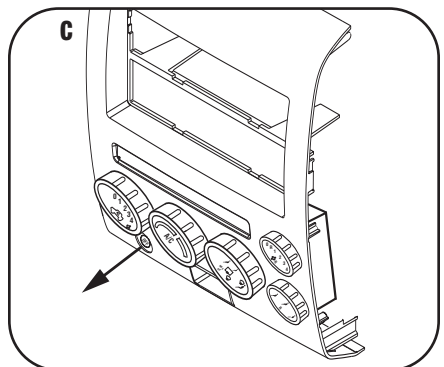
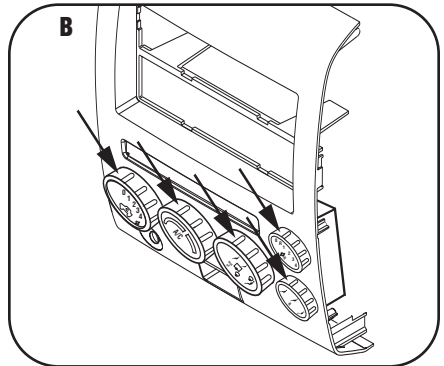
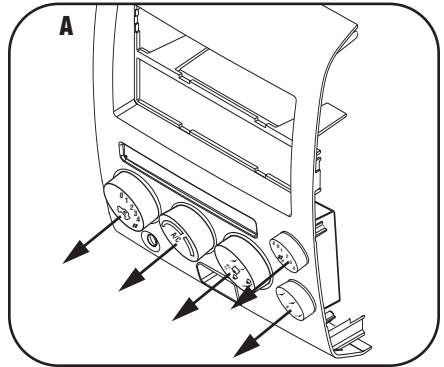

DIN HEAD UNIT PROVISION

**Note: Refer also to the instructions included with the aftermarket radio.*

- 1 Slide the DIN cage into the Radio Housing and secure by bending the metal locking tabs down. (Figure A)
- 2 Slide the aftermarket head unit into the cage and secure. (Figure B)

Continue to final assembly.

A

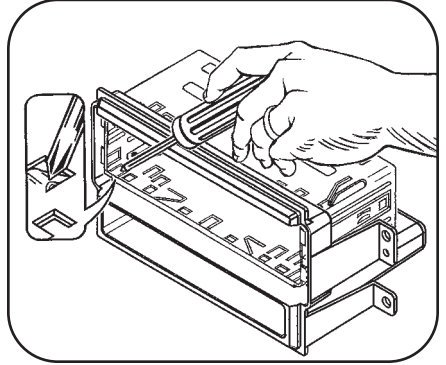

B

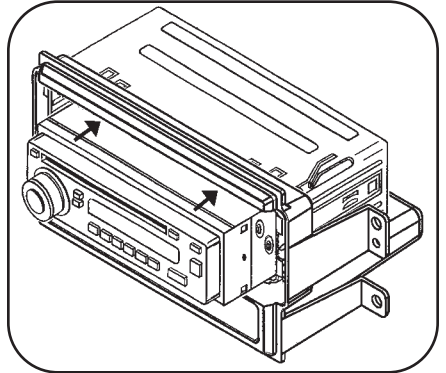

ISO DIN HEAD UNITS PROVISION

**Note: Refer also to the instructions included with the aftermarket radio.*

- 1** Mount the ISO Brackets to the head unit with the screws supplied with the unit. (Figure A)
- 2** Slide the head unit into the radio opening until the side clips engage. (Figure B)
- 3** Snap the Trim plate into the Radio Housing. (Figure B)

Continue to final assembly.

A

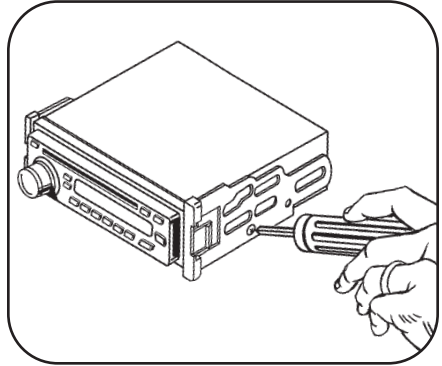

B

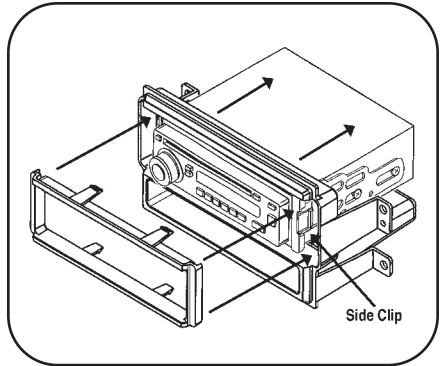

FINAL ASSEMBLY

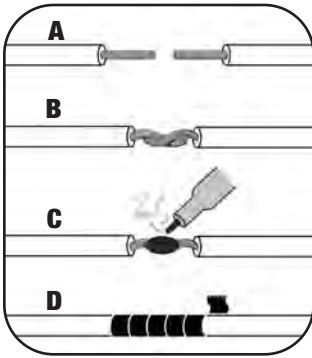

- (A) Strip wire ends back 1/2"**
- B) Twist ends together**
- C) Solder**
- D) Tape**

- 1** Locate the factory wiring harness in the dash. Metra recommends using the proper mating adapter and making connections as shown. (Isolate and individually tape off the ends of any unused wires to prevent electrical short circuit.)
- 2** Re-connect the negative battery terminal and test the unit for proper operation.
- 3** Reassemble radio and dash assemblies in reverse order of disassembly.

FINAL WIRING CONNECTIONS

Make wiring connections using the EIA color code chart shown below and the instructions included with the head unit. Metra recommends making connections as shown below; Strip, Splice, Solder, Tape. Isolate and individually tape off ends of any unused wires to prevent electrical short circuit.

METRA / EIA WIRING CODE

12V Ignition / Acc. Red	Right Front (+) Gray
12V Batt / Memory. Yellow	Right Front (-). Gray/ Black
Ground. Black*	Left Front (+) White
Power Antenna. Blue	Left Front (-). White / Black
Amp Turn-On Blue / White	Right Rear (+) Violet
Amp Ground. Black / White	Right Rear (-). Violet / Black
Illumination Orange	Left Rear (+) Green
Dimmer Orange / White	Left Rear (-) Green / Black

***NOTE:** When a Black wire is not present, ground radio to vehicle chassis.
All colors may not be present on all leads due to manufacturer's specifications.

99-7406 INSTRUCTIONS



1-800-221-0932



www.metraonline.com

REV. 02/22/08 © COPYRIGHT 2004-2008 METRA ELECTRONICS CORPORATION INST99-7406