

KIT FEATURES

- ▶ Shaft and DIN unit provisions
- ▶ Equalizer provisions

KIT COMPONENTS

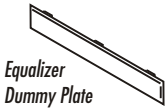
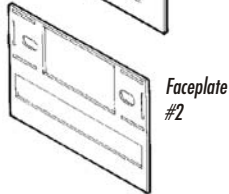
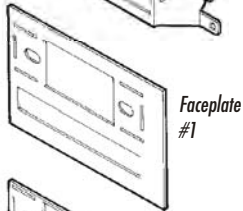
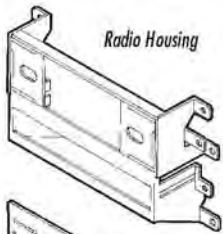

TOOLS REQUIRED



Phillips screwdriver



Cutting tool



Wrench



99-7408 INSTALLATION INSTRUCTIONS

APPLICATIONS

<u>CAR</u>	<u>PAGE</u>
NISSAN	
Maxima 1987-88.....	1
Pulsar 1987-90.....	1
Stanza 1990-92.....	2



☎ 1-800-221-0932 💻 www.metraonline.com

© COPYRIGHT 2001 METRA ELECTRONICS CORPORATION

NISSAN Maxima 1987-88

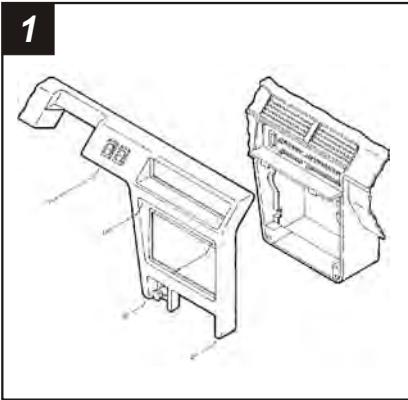

Disconnect the negative battery terminal to prevent an accidental short circuit. Remove (2) Phillips screws from the base of the dash trim bezel. Remove (2) Phillips screws above the radio opening. Remove (2) Phillips screws located to the left of the steering column. Remove (1) Phillips screw located to the right of the steering column. Unclip the dash trim bezel and remove. Remove (4) screws securing the factory head unit and disconnect the wiring.

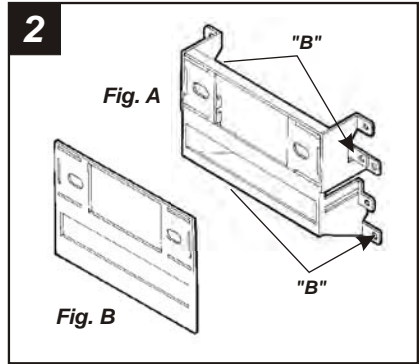

Cut and remove all mounting tabs on the **Radio Housing** EXCEPT tabs "**B**". The mounting tabs can be identified by the stamped letter on the back of each tab. (see Fig. A). Locate **Faceplate #2**. (see Fig. B). Skip to the Installation Instructions for ALL VEHICLES on Page #2.

NISSAN Pulsar 1987-90

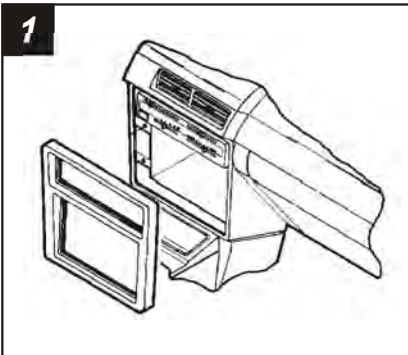

Disconnect the negative battery terminal to prevent an accidental short circuit. Remove (3) screws above the climate controls. Remove (2) screws from the base of the radio trim bezel. Unclip the bezel and remove. Remove (4) screws securing the factory head unit and disconnect the wiring.

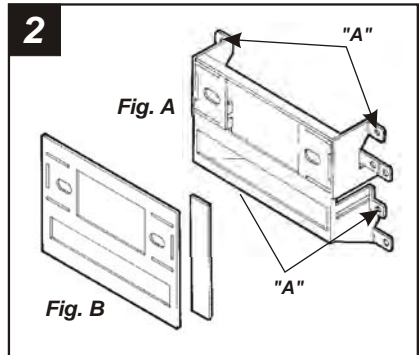

Cut and remove all mounting tabs on the **Radio Housing** EXCEPT tabs "**A**". The mounting tabs can be identified by the stamped letter on the back of each tab. (see Fig. A). Cut and remove the side portion **Faceplate #1**. (see Fig. B). Skip to the Installation Instructions for ALL VEHICLES on Page #2.

NISSAN Stanza 1990-92

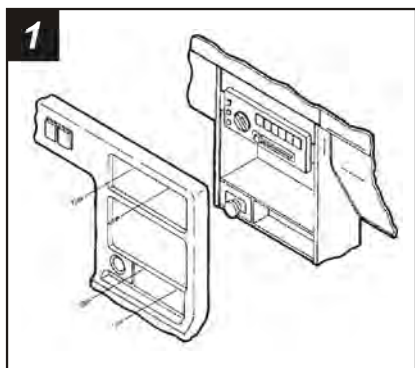

Disconnect the negative battery terminal to prevent an accidental short circuit. Remove the ashtray and (2) screws above the ashtray opening. Remove (2) screws above the radio opening. Remove (2) screws located to the left of the steering column. Remove (1) screw located to the right of the steering column. Unclip the dash trim bezel, and disconnect the flasher, rear defroster and headlight wiring. Remove the bezel. Remove (4) screws securing the factory head unit and disconnect the wiring.

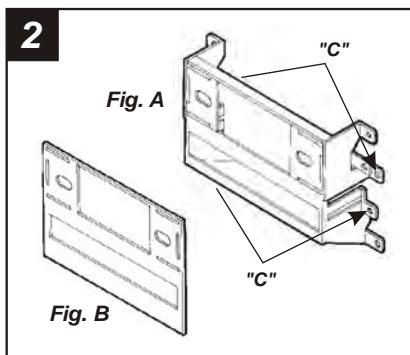

Cut and remove all mounting tabs on the **Radio Housing** EXCEPT tabs "C". The mounting tabs can be identified by the stamped letter on the back of each tab. (see Fig. A). Locate **Faceplate #2**. (see Fig. B). Skip to the **Installation Instructions for ALL VEHICLES** on Page #2.

ALL VEHICLES

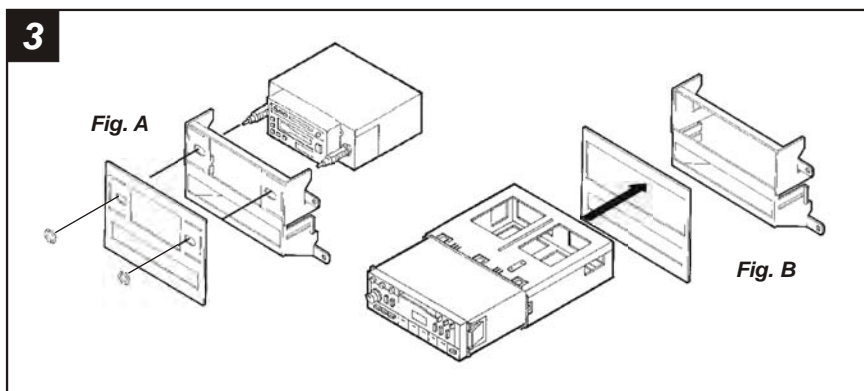

2-SHAFT HEAD UNITS: Attach the **Faceplate** to the **Radio Housing**. Slide the aftermarket head unit into the kit and secure with shaft nuts. (see Fig. A)

DIN HEAD UNITS: Cut and remove the shaft supports from the **Faceplate** and **Radio Housing**. Attach the Faceplate to the Housing. Slide the DIN cage into the kit and secure by bending the metal locking tabs down. Slide the aftermarket head unit into the cage until secure. (see Fig. B)

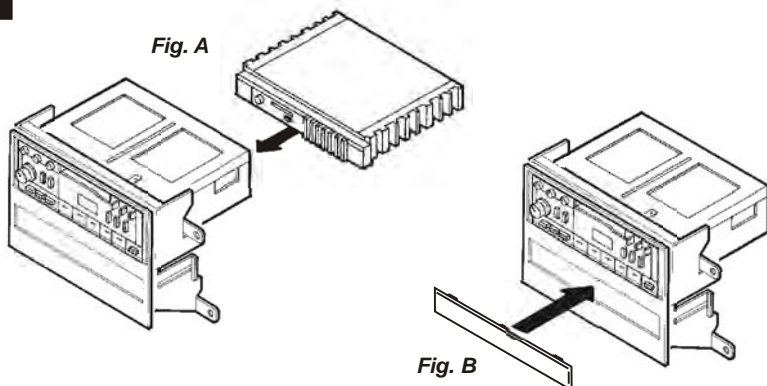
4

IF AN EQUALIZER WILL BE INCLUDED: Slide the aftermarket equalizer into the back of the **Radio Housing**. Using the hardware included with the equalizer, mount the unit to the kit. (see Fig. A)

IF AN EQUALIZER WILL NOT BE INCLUDED: Snap the **Equalizer Dummy Plate** into the **Radio Housing**. (see Fig. B)

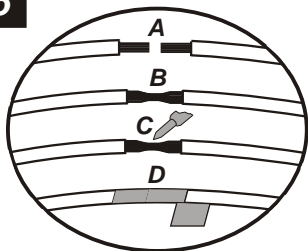
5

- A) Strip wire ends back ½"**
- B) Twist ends together**
- C) Solder**
- D) Tape**

Locate the factory wiring harness in the dash. Metra recommends using the proper mating adaptor and making connections as shown. (Isolate and individually tape off the ends of any unused wires to prevent electrical short circuit).

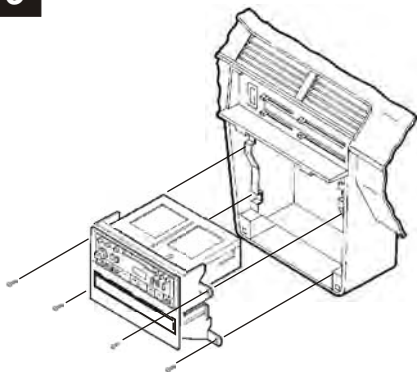
6

Re-connect the battery terminal and test the unit for proper operation. Mount the head unit/kit assembly to the sub-dash with (4) screws previously removed in step #1.