

## KIT FEATURES

- ▶ Shaft and DIN unit provisions



# 99-7411 INSTALLATION INSTRUCTIONS

## KIT COMPONENTS

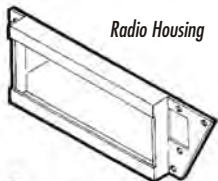

Radio Housing

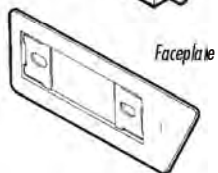

Faceplate



(4) Phillips Pan-head Screws



(4) Speed Clips

## APPLICATIONS

### CAR

### PAGE

NISSAN

300ZX 1984-87.....1-2



## TOOLS REQUIRED



Phillips screwdriver



Cutting tool



Wrench

☎ 1-800-221-0932    💻 [www.metraonline.com](http://www.metraonline.com)

© COPYRIGHT 2001 METRA ELECTRONICS CORPORATION

rev. 250701

# ALL VEHICLES

1

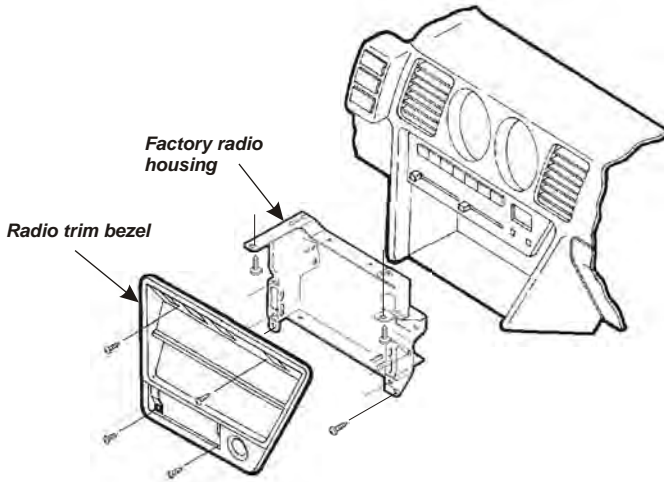

Disconnect the negative battery terminal to prevent an accidental short circuit. Remove the ashtray and (2) screws exposed. Remove (2) screws above the climate controls. Unclip the radio trim bezel and remove. Remove (4) Phillips screws securing the factory radio housing, pull the housing assembly out and disconnect the wiring. Remove the screws securing the factory radio to the factory radio housing and remove.

2a

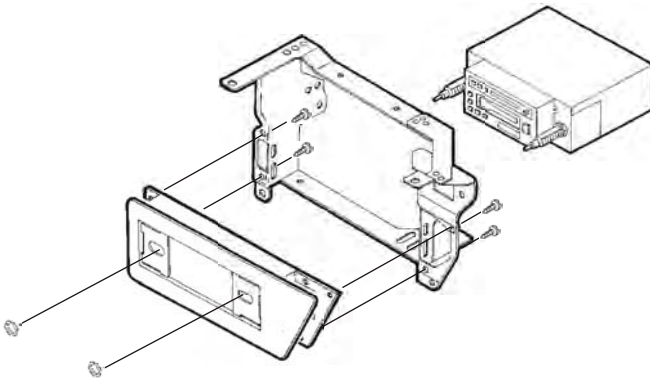

**2-SHAFT HEAD UNITS:** Snap the **Faceplate** onto the the front of the **Radio Housing**. Mount the Faceplate/Radio Housing assembly to the factory radio housing with (4) **Phillips Pan-head Screws** and (4) **Speed Clips** supplied. Slide the aftermarket head unit into the kit and secure with shaft nuts.

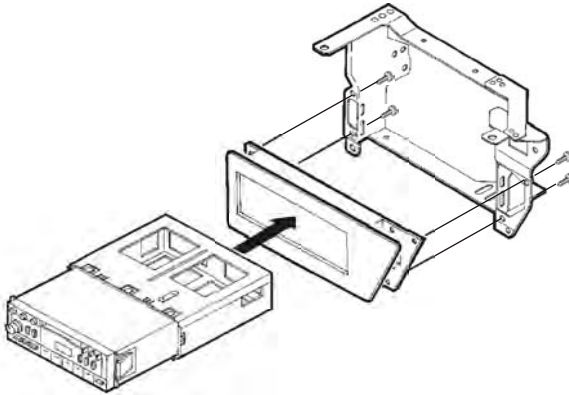
**2b**

**DIN HEAD UNITS:** Cut and remove the shaft supports from the **Faceplate**. Snap the Faceplate onto the front of the **Radio Housing**. Mount the Faceplate/Radio Housing assembly to the factory radio housing with **(4) Phillips Pan-head Screws** and **(4) Speed Clips** supplied. Slide the DIN cage into the Housing and secure by bending the metal locking tabs down. Slide the aftermarket head unit into the cage until secure.

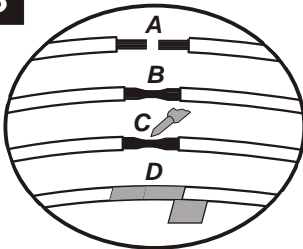
**3**

- A) Strip wire ends back ½"
- B) Twist ends together
- C) Solder
- D) Tape

Locate the factory wiring harness in the dash. Metra recommends using the proper mating adaptor and making connections as shown. (Isolate and individually tape off the ends of any unused wires to prevent electrical short circuit).

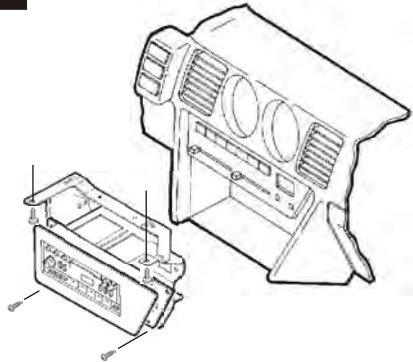
**4**

Re-connect the battery terminal and test the unit for proper operation. Mount the factory radio housing to the sub-dash with (4) Phillips screws previously removed in step #1.