

KIT FEATURES

- ▶ DIN head unit provisions



99-7415

INSTALLATION INSTRUCTIONS

KIT COMPONENTS

Radio Housing

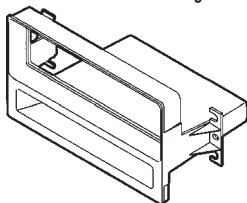

APPLICATIONS

<u>CAR</u>	<u>PAGE</u>
MERCURY	
Villager 1999-02	1-2
NISSAN	
Quest 1999-03	1-2



TOOLS REQUIRED



Phillips screwdriver



1-800-221-0932



www.metraonline.com

© COPYRIGHT 2001 METRA ELECTRONICS CORPORATION

rev. 20120

ALL VEHICLES

1

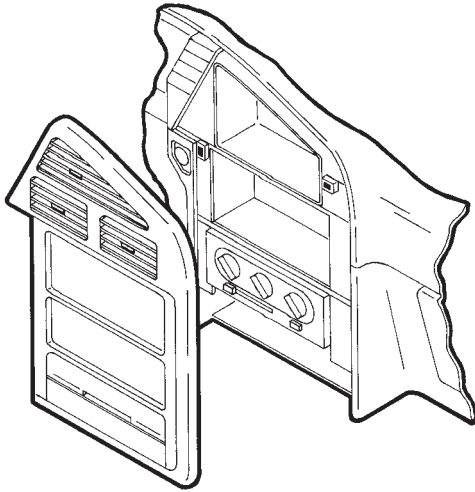

Disconnect the negative battery terminal to prevent an accidental short circuit. Open the ashtray/cupholder assembly, depress the retaining clips on each side and remove the assembly. Remove (2) Phillips screws from each side of the ashtray/cupholder assembly. Remove (4) plastic rivets from the lower pocket and slide the pocket back. (NOTE: It is NOT necessary to remove the pocket. Unclip the dash trim bezel and remove. Remove (4) Phillips screws securing the factory head unit and disconnect the wiring.

2

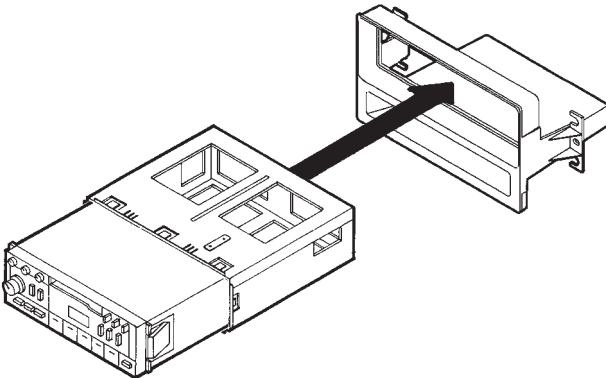

Slide the DIN cage into the Radio Housing and secure by bending the metal locking tabs down. Slide the aftermarket head unit into the DIN cage until secure.

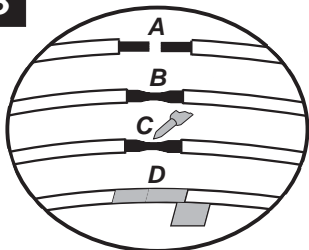
3

- A) Strip wire ends back 1/2"**
- B) Twist ends together**
- C) Solder**
- D) Tape**

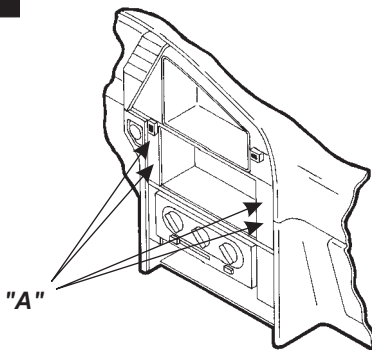
4

Locate the factory wiring harness in the dash. Metra recommends using the proper mating adaptor and making connections as shown. (Isolate and individually tape off the ends of any unused wires to prevent electrical short circuit).

Locate the (4) mounting positions in the sub-dash ("A").

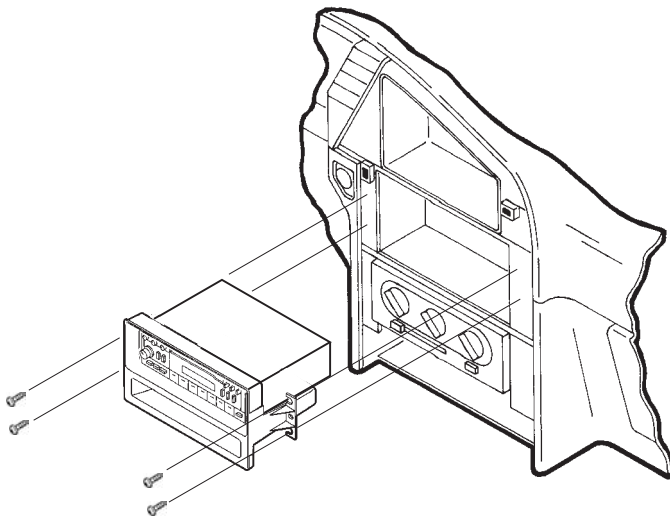
5

Re-connect the battery terminal and test the unit for proper operation. Mount the head unit/kit assembly to the sub-dash with (4) Phillips screws previously removed in step #1.