

**KIT FEATURES**

- ▶ Shaft and DIN unit provisions



# 99-7477

## INSTALLATION INSTRUCTIONS

**KIT COMPONENTS**

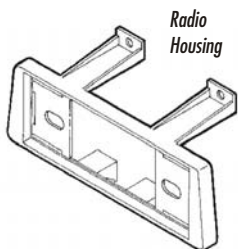

Radio Housing

**APPLICATIONS**

<b>CAR</b>	<b>PAGE</b>
<b>NISSAN</b>	
Hardbody Pickup 1987-93.....	1-2
Pathfinder 1987-93.....	1-2

**TOOLS REQUIRED**



Phillips screwdriver



Cutting tool



Adjustable wrench



☎ 1-800-221-0932    💻 [www.metraonline.com](http://www.metraonline.com)

© COPYRIGHT 2001 METRA ELECTRONICS CORPORATION

rev. 250701

# ALL VEHICLES

1

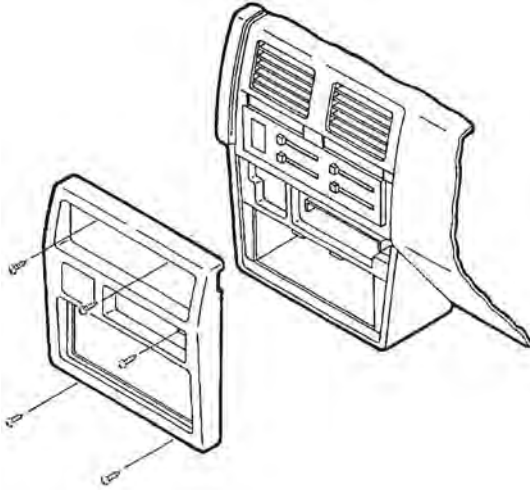

Disconnect the negative battery terminal to prevent an accidental short circuit. Remove the ashtray and (1) screw exposed in the top-right corner of the ashtray cavity. Remove (2) Phillips screws above the climate controls. Remove (2) Phillips screws from the base of the radio trim bezel. Unclip the radio trim bezel and disconnect the cigarette lighter wiring. Remove the bezel. Remove (4) screws securing the factory head unit and disconnect the wiring.

2

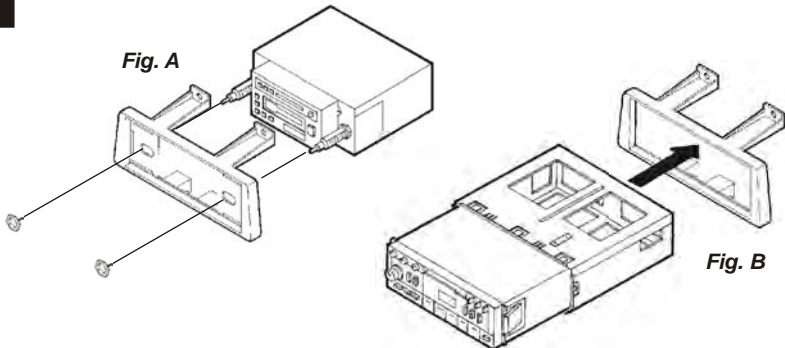

**2-SHAFT HEAD UNITS:** Slide the aftermarket head unit into the kit and secure with shaft nuts. (see Fig. A)

**DIN HEAD UNITS:** Cut and remove the shaft supports from the **Radio Housing**. Slide the DIN cage into the kit and secure by bending the metal locking tabs down. Slide the aftermarket head unit into the cage until secure. (see Fig. B)

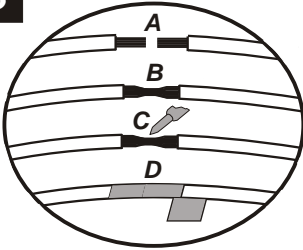
**3**

- A) Strip wire ends back 1/2"**
- B) Twist ends together**
- C) Solder**
- D) Tape**

Locate the factory wiring harness in the dash. Metra recommends using the proper mating adaptor and making connections as shown. (Isolate and individually tape off the ends of any unused wires to prevent electrical short circuit).

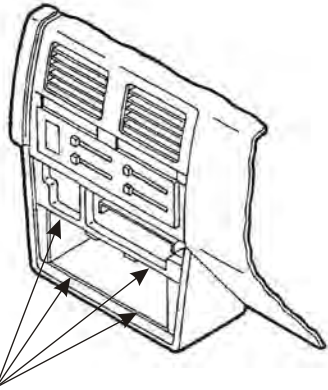
**4****"A"**

Locate the (4) mounting positions in the sub-dash ("A").

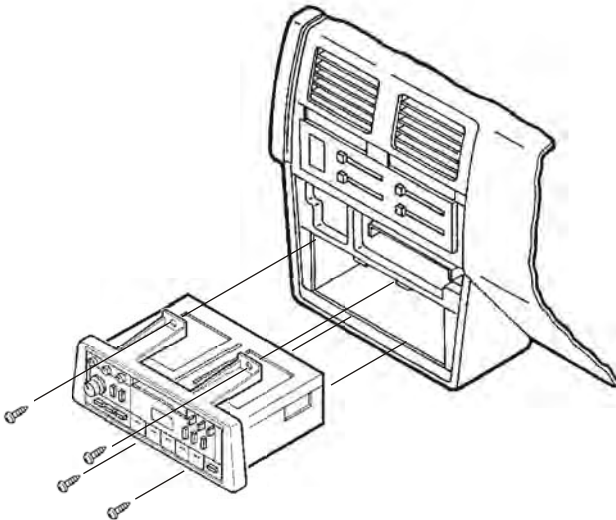
**5**

Re-connect the battery terminal and test the unit for proper operation. Mount the head unit/kit assembly to the sub-dash with (4) screws previously removed in step #1.