

KIT COMPONENTS

99-7500 DW-7501

INSTALLATION INSTRUCTIONS

APPLICATIONS**CAR****PAGE****MAZDA**

323 1986-89*	1
323 1990-94*	1
626 (models w/factory receiver/tape deck/eq/pocket) 1986-92...	2
626 (models w/factory receiver/pocket) 1986-92* ■	2
929 1988-91	3
B-Series Pickup 1986-93	3
Miata 1990-99	4
MPV 1989-95*	4
MX6 (models w/factory receiver/tape deck/eq/pocket) 1986-92...	2
MX6 (models w/factory receiver/pocket) 1986-92*	2
Protege 1990-94*	1
RX-7 1986-91	5

* For aftermarket DIN head unit installations, order Metra's 99-7501

■ For models with pockets 3 $\frac{3}{4}$ " or taller, order Metra's 99-7501

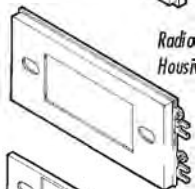
Radio
Housing #1Radio
Housing #2

Trimplate

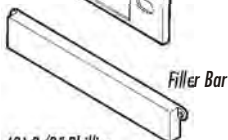

Filler Bar

(8) 3/8" Phillips
Screws

(6) 3/8" Hex-head Screws



(6) 3/8" Hex-head Screws

(4) 1/2" Hex-head
Screws

Bracket Set #1

Equalizer
Dummy
Plate**TOOLS REQUIRED**

Phillips screwdriver



Cutting tool



Socket wrench

☎ 1-800-221-0932 💻 www.metraonline.com

© COPYRIGHT 2001 METRA ELECTRONICS CORPORATION

MAZDA 323 1986-89

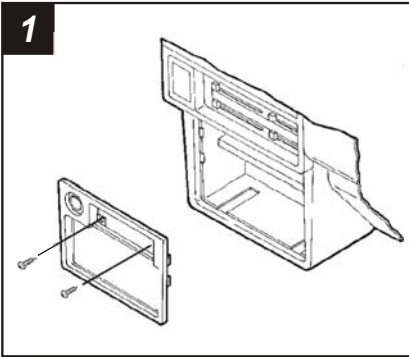

Disconnect the negative battery terminal to prevent an accidental short circuit. Remove the ashtray and (2) screws exposed in the ashtray cavity. Unclip the radio trim bezel and disconnect the wiring. Remove (4) screws securing the factory dummy plate to the back of the bezel and discard the plate.

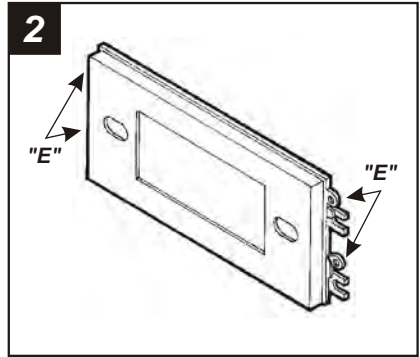

Cut and remove all mounting tabs on **Radio Housing #2** EXCEPT tabs "E". The mounting tabs can be identified by the stamped letter on the back of each tab. Skip to the *Installation Instructions for ALL VEHICLES on Page #5.*

MAZDA 323 / Protege 1990-94

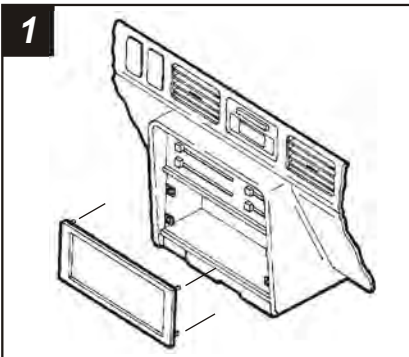

Disconnect the negative battery terminal to prevent an accidental short circuit. Gently pry out on the radio trim bezel and remove. Remove (4) screws securing the factory head unit and disconnect the wiring.

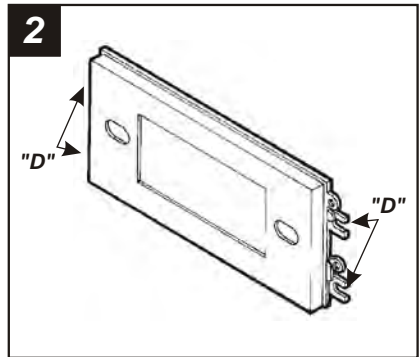

Cut and remove all mounting tabs on **Radio Housing #2** EXCEPT tabs "D". The mounting tabs can be identified by the stamped letter on the back of each tab. Skip to the *Installation Instructions for ALL VEHICLES on Page #5.*

MAZDA 626 / MX6 1986-92

(models equipped with factory receiver/pocket)

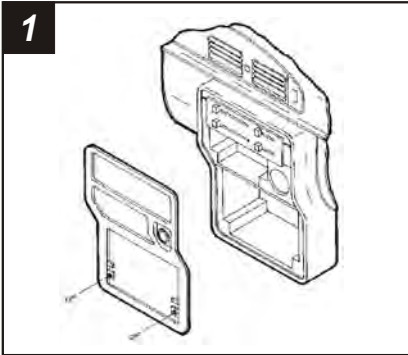

Disconnect the negative battery terminal to prevent an accidental short circuit. Remove the ashtray and (2) screws exposed. Remove the pocket and (2) screws exposed. Remove the radio trim bezel and disconnect the wiring. Remove (4) screws securing the factory dummy plate to the back of the bezel and discard the plate.

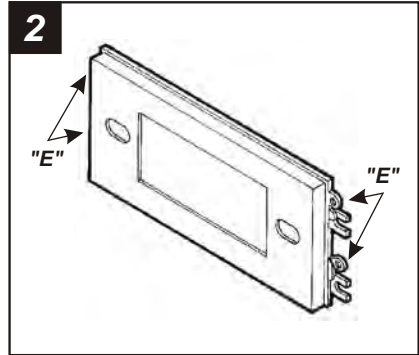

Cut and remove all mounting tabs on **Radio Housing #2** EXCEPT tabs "E". The mounting tabs can be identified by the stamped letter on the back of each tab. Skip to the Installation Instructions for ALL VEHICLES on Page #5.

MAZDA 626 / MX6 1986-92

(models equipped with factory receiver/tape deck/eq/pocket)

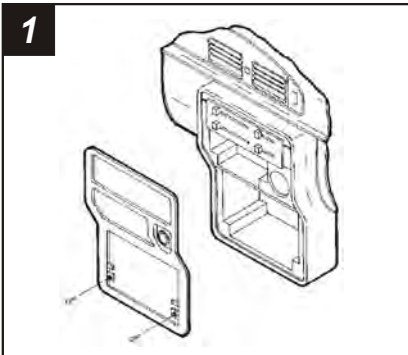

Disconnect the negative battery terminal to prevent an accidental short circuit. Remove the ashtray and (2) screws exposed. Remove the pocket and (2) screws exposed. Remove the radio trim bezel and disconnect the wiring. Remove (4) screws securing the factory dummy plate to the back of the bezel and discard the plate.

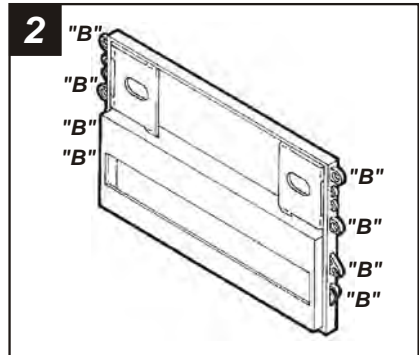

Cut and remove all mounting tabs on **Radio Housing #1** EXCEPT tabs "B". The mounting tabs can be identified by the stamped letter on the back of each tab. Skip to the Installation Instructions for ALL VEHICLES on Page #5.

MAZDA 929 1988-91

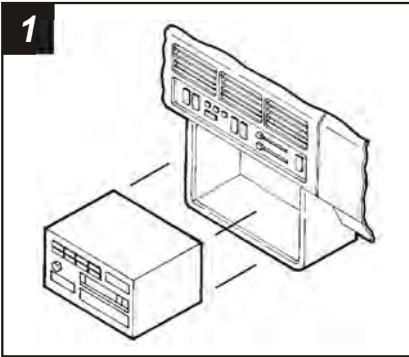

1
Disconnect the negative battery terminal to prevent an accidental short circuit. Reach behind the console and remove (2) nuts supporting the head unit carrier. Remove the factory head unit and disconnect the wiring..

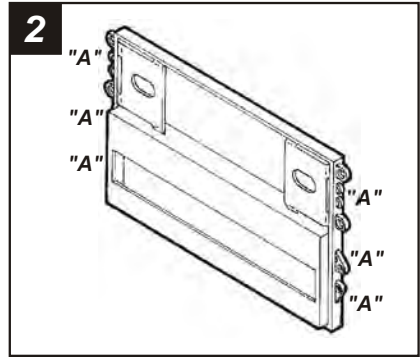

2
Cut and remove all mounting tabs on **Radio Housing #1** EXCEPT tabs "A". The mounting tabs can be identified by the stamped letter on the back of each tab. Skip to the *Installation Instructions for ALL VEHICLES* on Page #5.

MAZDA B-Series Pickup 1986-93

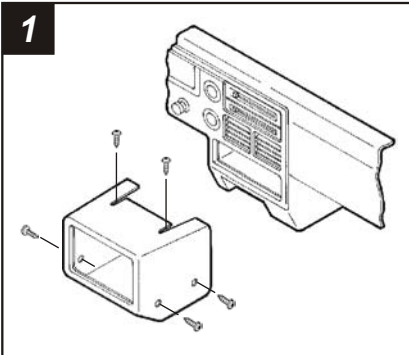

1
Disconnect the negative battery terminal to prevent an accidental short circuit. Remove (2) screws from each side of the radio trim bezel. Remove the ashtray and (1) screw from the rear support tab. Remove the radio trim bezel/sub-bracket assembly. Remove (4) screws securing the sub-bracket to the back of the radio trim bezel. Loosen (2) screws on top of the bezel and remove the sub-bracket from the bezel.

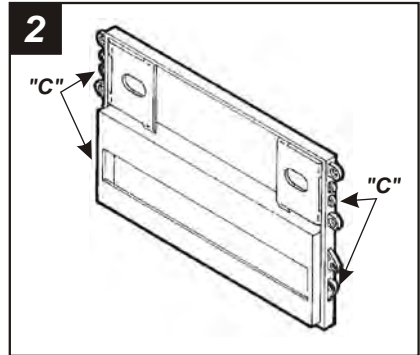

2
Cut and remove all mounting tabs on **Radio Housing #1** EXCEPT tabs "C". The mounting tabs can be identified by the stamped letter on the back of each tab. Skip to the *Installation Instructions for ALL VEHICLES* on Page #5.

MAZDA Miata 1990-99

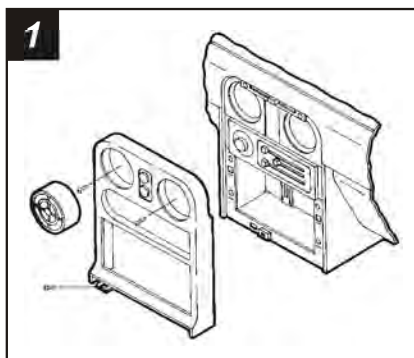

Disconnect the negative battery terminal to prevent an accidental short circuit. Remove (2) screws from the center console storage compartment. Remove (1) screw under the ashtray. Remove (1) screw from each side of the center console panel and remove the panel. Remove (1) screw exposed at the base of the dash trim bezel. Pop out the a/c vents and remove (2) screws exposed. Remove the dash trim bezel.

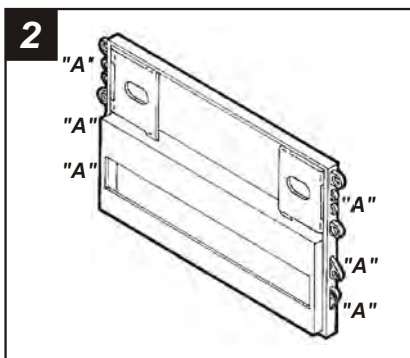

Cut and remove all mounting tabs on **Radio Housing #1** EXCEPT tabs "A". The mounting tabs can be identified by the stamped letter on the back of each tab. Skip to the *Installation Instructions for ALL VEHICLES* on Page #5.

MAZDA MPV 1989-95

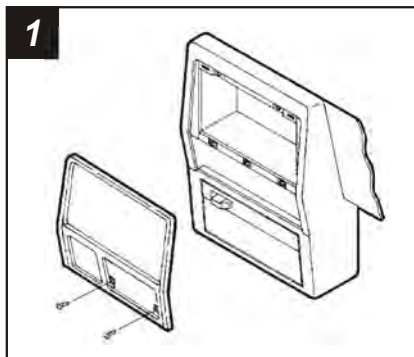

Disconnect the negative battery terminal to prevent an accidental short circuit. Remove the ashtray and (2) screws exposed in the ashtray cavity. Remove the radio trim bezel and disconnect the wiring. Remove (4) screws securing the factory head unit and disconnect the wiring.

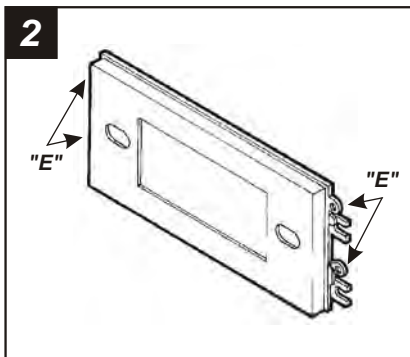

Cut and remove all mounting tabs on **Radio Housing #2** EXCEPT tabs "E". The mounting tabs can be identified by the stamped letter on the back of each tab. Skip to the *Installation Instructions for ALL VEHICLES* on Page #5.

MAZDA RX-7 1986-91

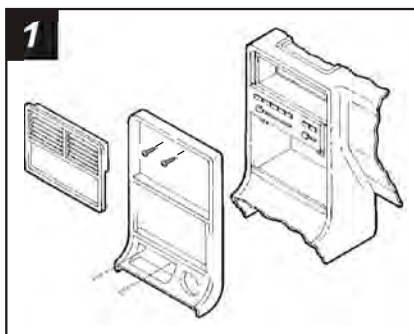

Disconnect the negative battery terminal to prevent an accidental short circuit. Remove the ashtray and (2) screws exposed in the ashtray cavity. Unsnap the gear shifter trim and remove (2) screws exposed. Unsnap the climate control trim bezel and remove (2) screws exposed. Remove the dash trim bezel and disconnect the wiring. Remove (4) screws securing the factory head unit and disconnect the wiring.

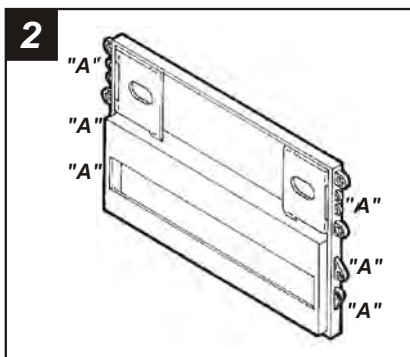

Cut and remove all mounting tabs on **Radio Housing #1** EXCEPT tabs "A". The mounting tabs can be identified by the stamped letter on the back of each tab. Skip to the *Installation Instructions for ALL VEHICLES* on Page #5.

ALL VEHICLES

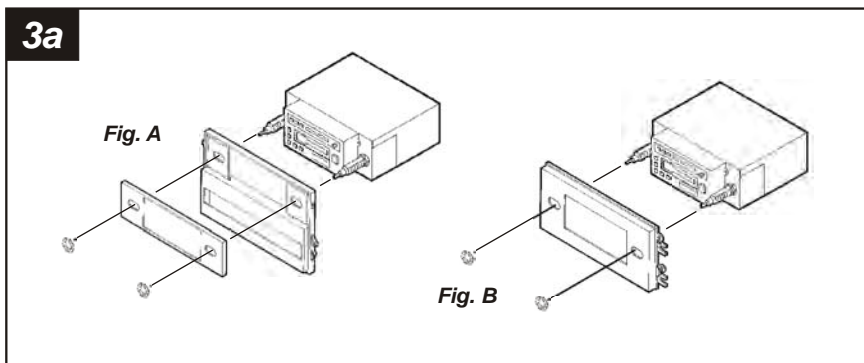

2-SHAFT HEAD UNITS: For models using **Radio Housing #1**, attach the **Faceplate** to the Housing. Slide the aftermarket head unit into the kit and secure with shaft nuts. (see Fig. A). For models using **Radio Housing #2**, slide the aftermarket head unit into the kit and secure with shaft nuts. (see Fig. B)

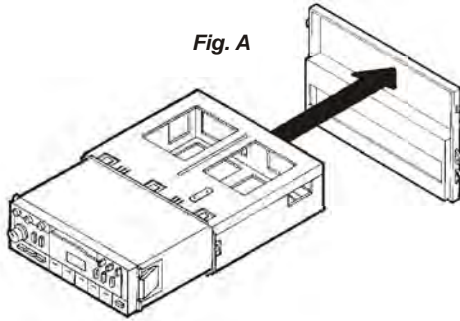
3b

DIN HEAD UNITS: For models using **Radio Housing #1**, cut and remove the shaft supports. Slide the DIN cage into the Housing and secure by bending the metal locking tabs down. Slide the aftermarket head unit into the cage until secure. (see Fig. A)

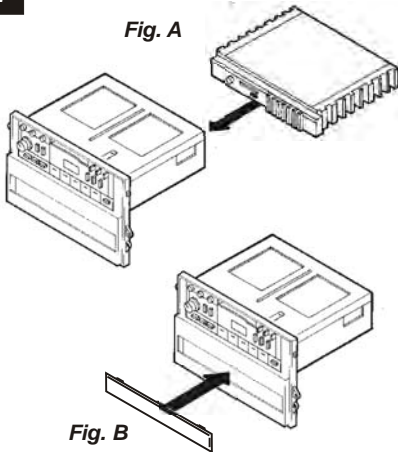
4

IF AN EQUALIZER WILL BE INCLUDED: Slide the aftermarket equalizer into the back of the **Radio Housing**. Using the hardware included with the equalizer, mount the unit to the kit. (see Fig. A)

IF AN EQUALIZER WILL NOT BE INCLUDED: Snap the **Equalizer Dummy Plate** into the **Radio Housing**. (see Fig. B)

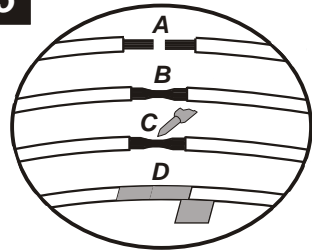
5

- A) Strip wire ends back $\frac{1}{2}$ "
- B) Twist ends together
- C) Solder
- D) Tape

Locate the factory wiring harness in the dash. Metra recommends using the proper mating adaptor and making connections as shown. (Isolate and individually tape off the ends of any unused wires to prevent electrical short circuit).

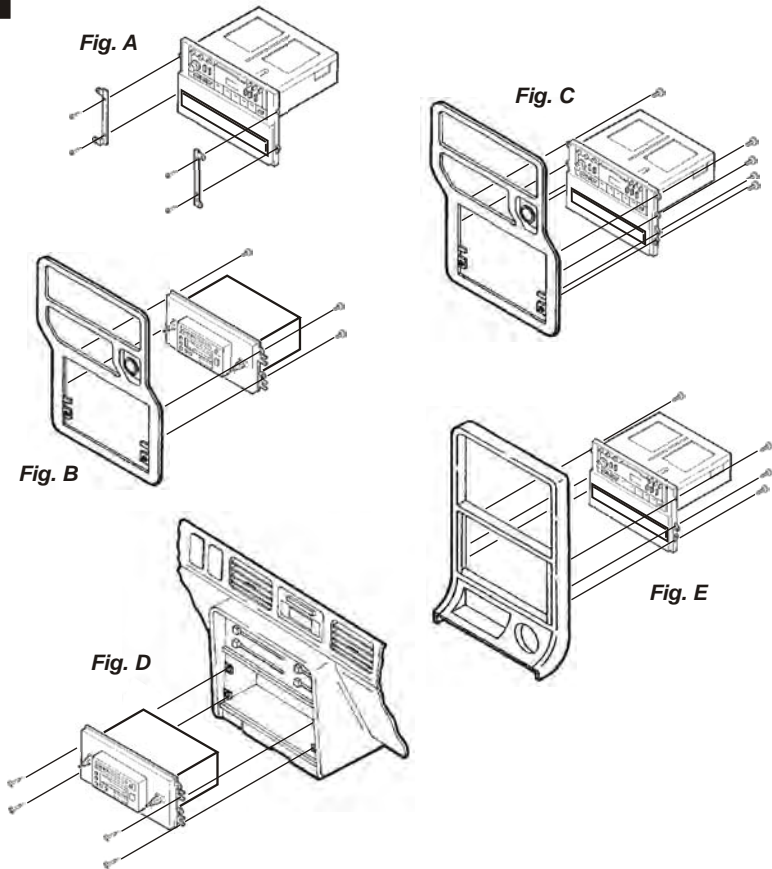

B-SERIES PICKUP: Re-connect the battery terminal and test the unit for proper operation. Mount **Bracket Set #1** to the Housing with **(4) ½" Hex-head Screws** supplied. Mount the head unit/kit assembly to the back of the dash trim bezel with **(4)** screws removed in step #1 and re-attach the bezel. (see Fig. A)

323 1986-89, 626 / MX6 (models using Radio Housing #2): Re-connect the battery terminal and test the unit for proper operation. Mount the head unit/kit assembly to the back of the dash trim bezel with **(4) 3/8" Phillips Screws** supplied and re-attach the bezel. (see Fig. B)

626 / MX6 (models using Radio Housing #1): Re-connect the battery terminal and test the unit for proper operation. Mount the head unit/kit assembly to the back of the dash trim bezel with **(8) 3/8" Phillips Screws** supplied and re-attach the bezel. (see Fig. C)

323 1990-94, MPV, PROTEGE: Re-connect the battery terminal and test the unit for proper operation. Mount the head unit/kit assembly to the sub-dash with **(4) ¼" Hex-head Screws** supplied. (see Fig. D)

929, MIATA, RX-7: Re-connect the battery terminal and test the unit for proper operation. Mount the head unit/kit assembly to the back of the dash trim bezel with **(6) 3/8" Hex-head Screws** supplied and re-attach the bezel. (see Fig. E)