



INSTALLATION INSTRUCTIONS FOR PART 99-7506

APPLICATIONS

Mazda MX-5 Miata 2006-2008

99-7506



KIT FEATURES

- DIN Head Unit Provision with pocket
- ISO DIN Head Unit Provision with pocket
- Double DIN Head Unit Provision
- Stacked ISO DIN Head Unit Provision

KIT COMPONENTS

- A) Radio Housing • B) Snap-In Pocket • C) ISO Brackets • D) ISO Trim Plate • E) Double DIN Brackets
• F) Double DIN Trim Plate

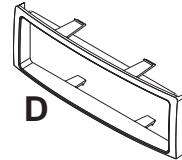
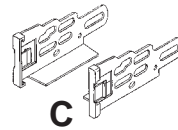
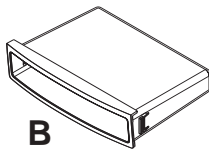
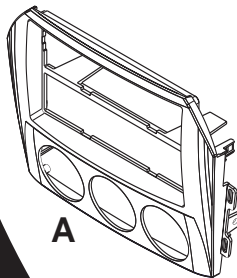

A

B

C

D

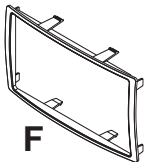

E

F

WIRING AND ANTENNA CONNECTIONS (Sold Separately)

Harness:

- 70-7903 - Mazda harness 2001-up

Antenna Adapter:

- Not required

TOOLS REQUIRED:

- Cutting Tool • Phillips Screwdriver • Socket Wrench

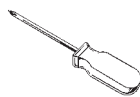
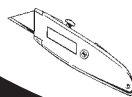

1-800-221-0932



www.metraonline.com

© COPYRIGHT 2004-2009 METRA ELECTRONICS CORPORATION

TABLE OF CONTENTS

<i>Dash Disassembly</i>	<i>1, 2</i>
<i>Kit Assembly:</i>	
<i>DIN Head Unit Provision.....</i>	<i>3</i>
<i>ISO DIN Head Unit Provision.....</i>	<i>4</i>
<i>Double DIN Head Unit Provision.....</i>	<i>5</i>
<i>Stacked ISO DIN Head Unit Provision.....</i>	<i>6</i>
<i>Final Assembly</i>	<i>7</i>



KNOWLEDGE IS POWER

Enhance your installation and fabrication skills by enrolling in the most recognized and respected mobile electronics school in our industry. Log onto www.installerinstitute.com or call 800-354-6782 for more information and take steps toward a better tomorrow.

MAZDA MX-5 MIATA 2006-2008

- 1** Disconnect the negative battery terminal to prevent an accidental short circuit.
- 2** Unclip panel below steering column and remove. (Figure A)
- 3** Remove (4) Phillips screws from metal brace below steering column and remove. (Figure A)
- 4** Looking at the side of the radio/climate control panel from underneath the steering column opening, remove (1) 10mm bolt from the side of the radio chassis. (Figure B)
- 5** Carefully remove the side panels from each side of the radio/climate control panel by pulling straight back towards the rear of the car. (Figure C)

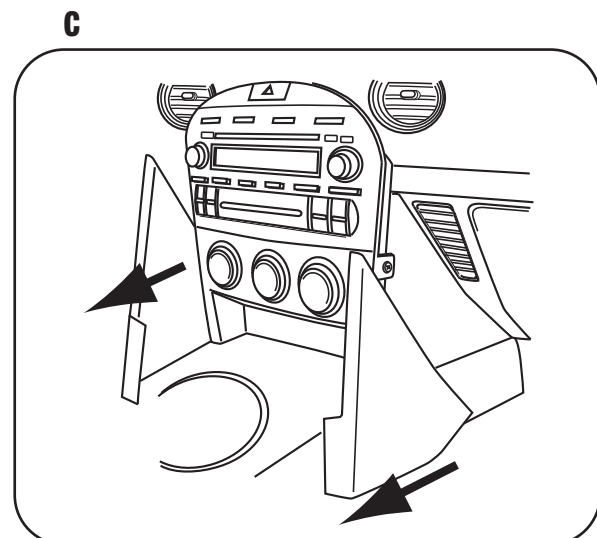
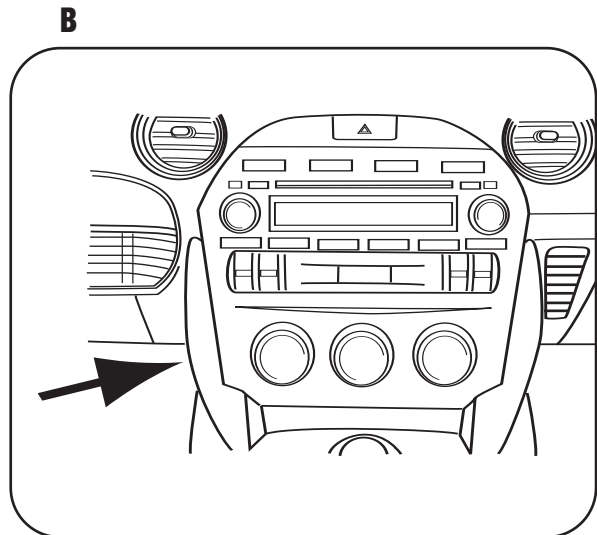
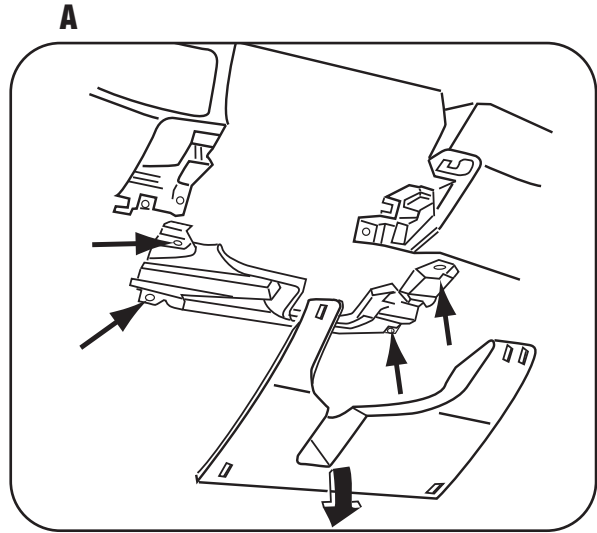

MAZDA MX-5 MIATA 2006-2008

- 6** Remove (2) Phillips screws, (1) on each side, from the side of the radio/climate control panel. (Figure D)

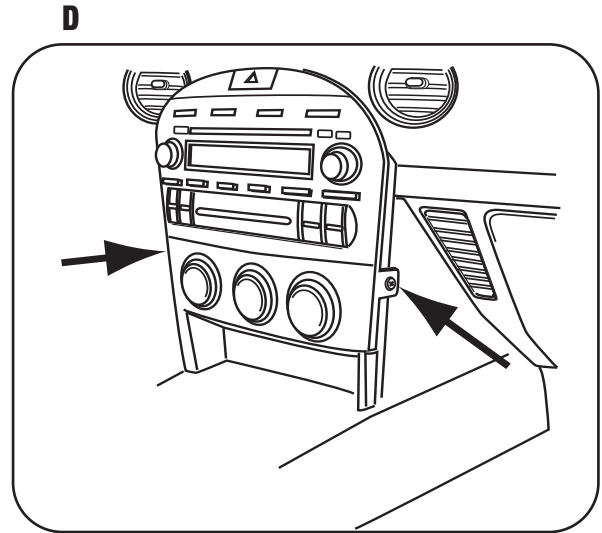

- 7** Pull radio/climate control panel out, disconnect plugs and remove. (Figure E)

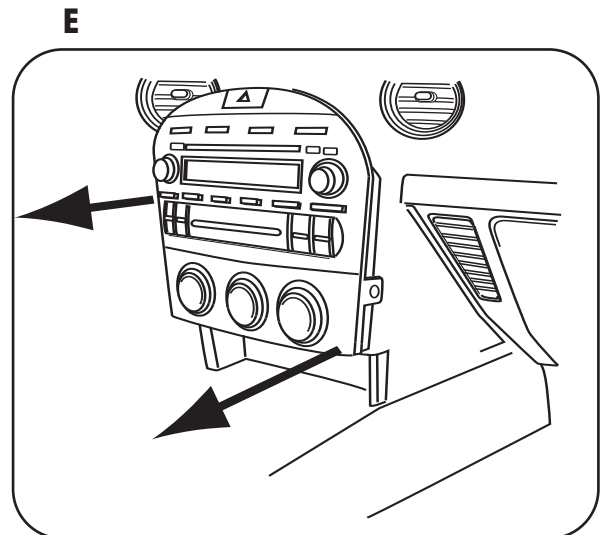

- 8** Turn the radio/climate control panel over and remove the (4) screws that hold the climate control to the bezel, then remove the climate control. (Figure F)

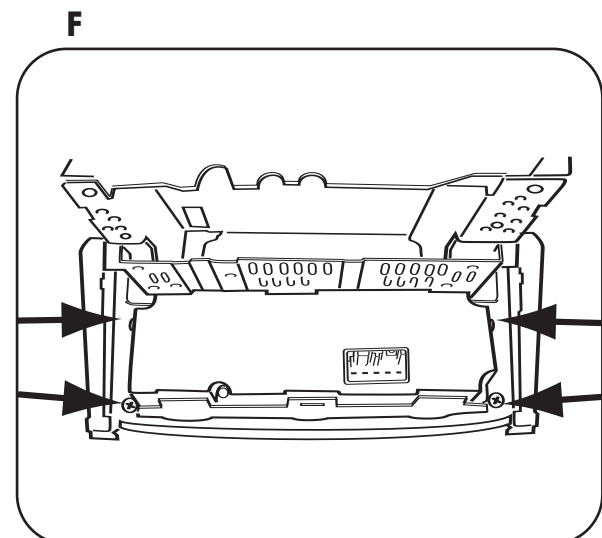

DIN HEAD UNIT PROVISION

- 1 Turn over the 99-7506 housing, take the climate control and screws removed from the factory panel and attach the climate control to the kit housing using the factory screws. (Figure A)

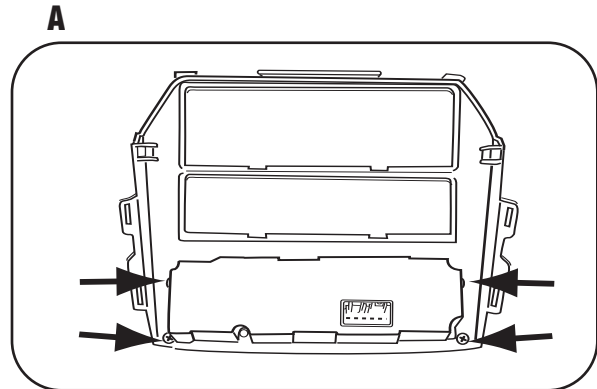

- 2 Slide the pocket into the bottom section of the kit housing. (Figure B)

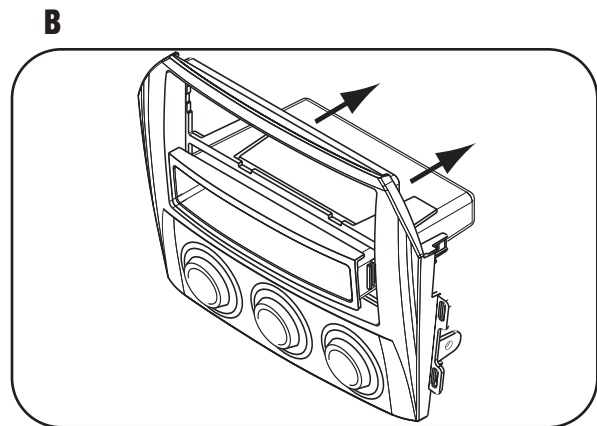

- 3 Slide the DIN cage into the Radio Housing and secure by bending the metal locking tabs down. (Figure C)

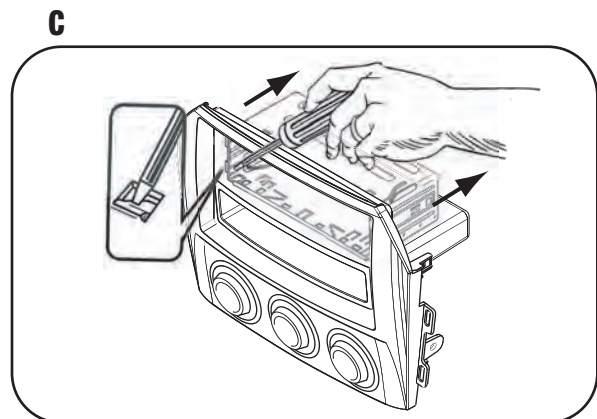

- 4 Slide the aftermarket head unit into the cage and secure. (Figure D)

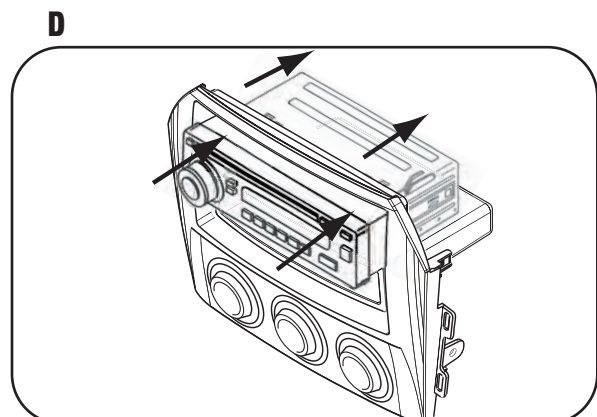

ISO DIN HEAD UNIT PROVISION

- 1 Turn over the 99-7506 housing, take the climate control and screws removed from the factory panel and attach the climate control to the kit housing using the factory screws. (Figure A)

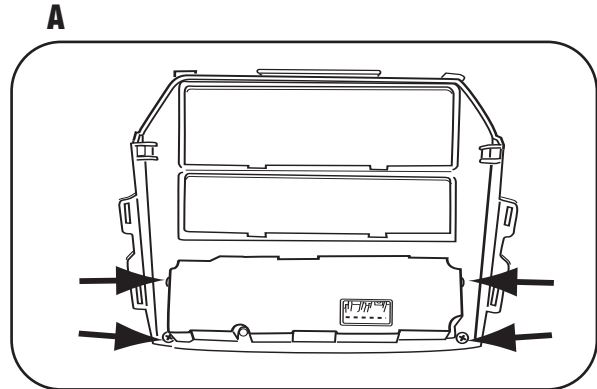

- 2 Slide the pocket into the bottom section of the kit housing. (Figure B)

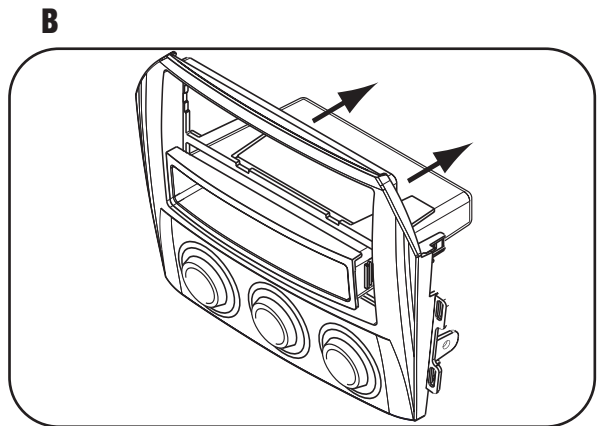

- 3 Mount the ISO Brackets to the head unit with the screws supplied with the unit. (Figure C)

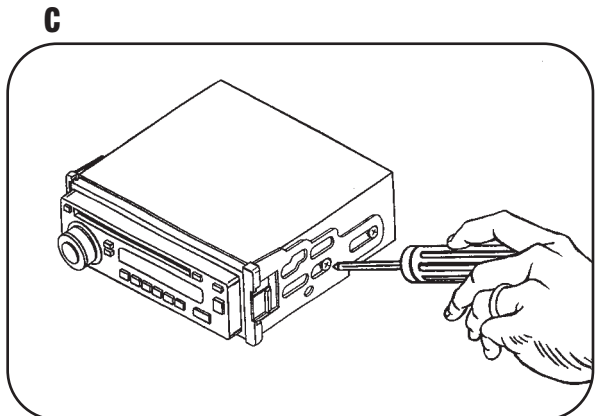

- 4 Slide the head unit into the radio opening until the side clips engage. (Figure D)

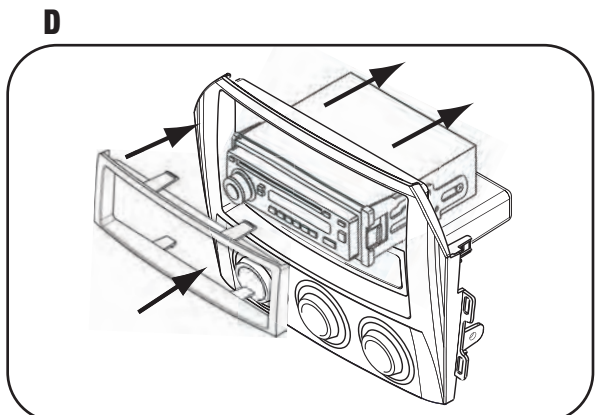

- 5 Snap the Trim plate into the Radio Housing. (Figure D)

DOUBLE DIN HEAD UNIT PROVISION

- 1 Turn over the 99-7506 housing, take the climate control and screws removed from the factory panel and attach the climate control to the kit housing using the factory screws. (Figure A)
- 2 Cut the rib in the middle of the 99-7506 housing to make room for the DDIN brackets. (Figure A)

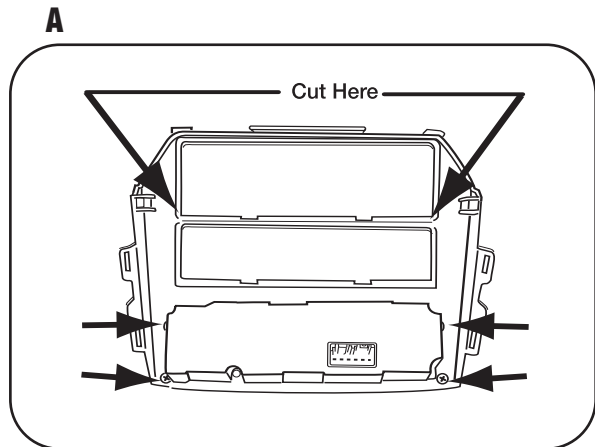

- 3 Slide the appropriate DDIN bracket into the kit housing. (Figure B)

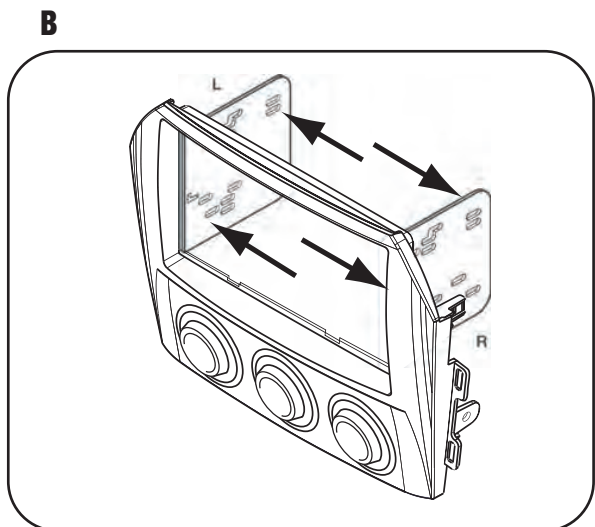

- 4 Slide the DDIN radio unit into DDIN brackets and secure the unit to the kit using the screws supplied with the head unit. (Figure C)

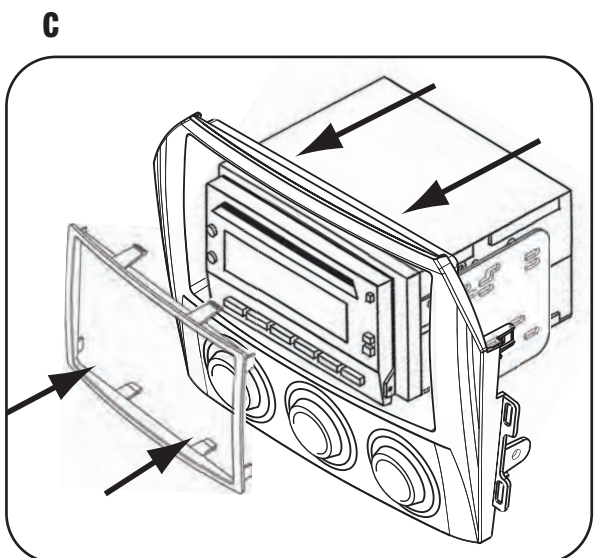

- 5 Snap the DDIN trim plate into the front of the kit housing. (Figure C)

STACKED ISO DIN HEAD UNIT PROVISION

1 Turn over the 99-7506 housing, take the climate control and screws removed from the factory panel and attach the climate control to the kit housing using the factory screws. (Figure A)

2 Cut the rib in the middle of the 99-7506 housing to make room for the DDIN brackets. (Figure A)

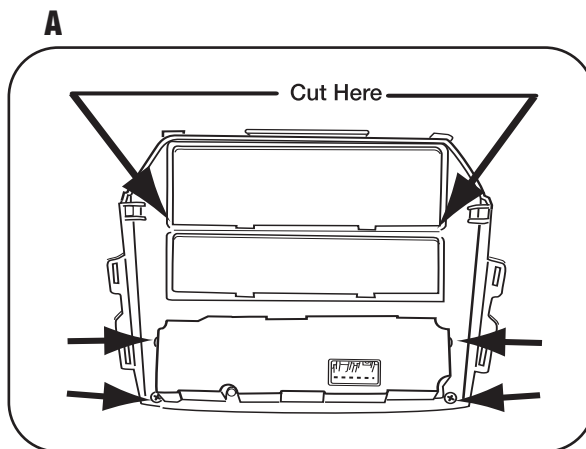

3 Slide the appropriate DDIN bracket into the kit housing. (Figure B)

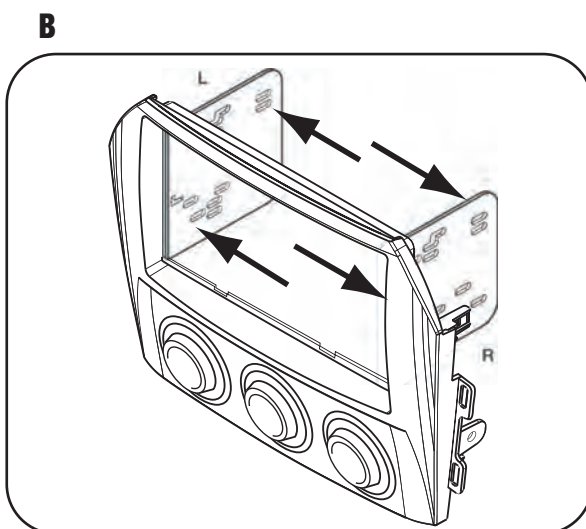

4 Slide the stacked ISO DIN units into the DDIN bracket assembly and secure the units to the kit using the screws supplied with the head units. (Figure C)

5 Snap the DDIN trim plate into the front of the kit housing. (Figure C)

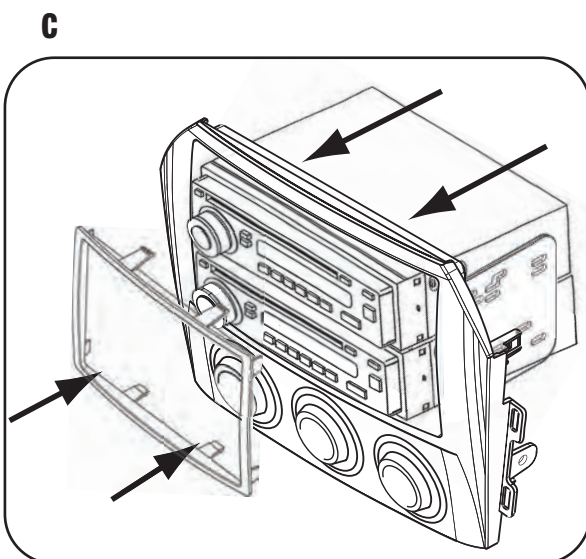

FINAL ASSEMBLY

- 1 Locate the factory wiring harness in the dash and make the connection as shown. Metra recommends using the proper mating adapter and making the connections as shown. (Isolate and individually tape off the ends of any unused wires to prevent electrical short circuit.)
- 2 Re-connect the negative battery terminal and test the unit for proper operation.
- 3 Reassemble radio and dash assemblies in reverse order of disassembly.

FINAL WIRING CONNECTIONS

Make wiring connections using the EIA color code chart shown below and the instructions included with the head unit. Metra recommends making connections as shown below; Strip, Splice, Solder, Tape. Isolate and individually tape off ends of any unused wires to prevent electrical short circuit.

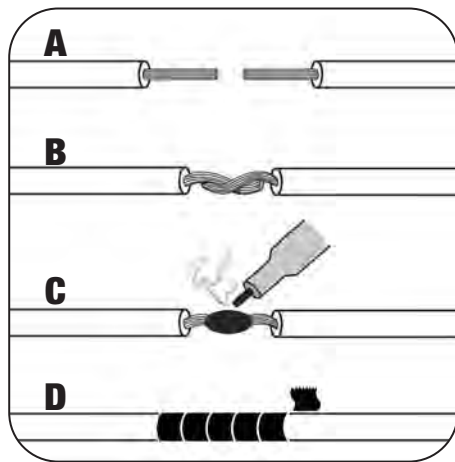

- A) Strip wire ends back 1/2"**
- B) Twist ends together**
- C) Solder**
- D) Tape**

METRA / EIA WIRING CODE

12V Ignition / Acc . . . Red	Right Front (+) Gray
12V Batt / Memory . . . Yellow	Right Front (-) Gray / Black
Ground Black*	Left Front (+) White
Power Antenna Blue	Left Front (-) White / Black
Amp Turn-On Blue / White	Right Rear (+) Violet
Amp Ground Black / White	Right Rear (-) Violet / Black
Illumination Orange	Left Rear (+) Green
Dimmer Orange / White	Left Rear (-) Green / Black

***NOTE:** When Black a wire is not present, ground radio to vehicle chassis.

All colors may not be present on all leads due to manufacturer's specifications.

99-7506 INSTRUCTIONS



1-800-221-0932



www.metraonline.com

REV. 06/26/09 © COPYRIGHT 2004-2007 METRA ELECTRONICS CORPORATION INST99-7506