

## KIT FEATURES

- ▶ Shaft and DIN unit provisions
- ▶ Equalizer provisions
- ▶ Various mounting depth alternatives



# 99-7579 INSTALLATION INSTRUCTIONS

## KIT COMPONENTS

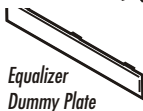
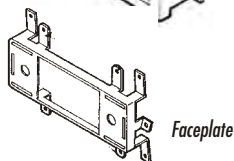
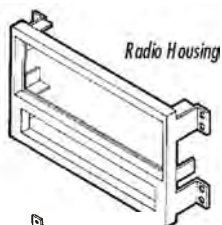

## APPLICATIONS

### CAR

### PAGE

### NISSAN

Pathfinder 1996-00.....1-2



## TOOLS REQUIRED



Phillips screwdriver



Adjustable wrench



1-800-221-0932



[www.metraonline.com](http://www.metraonline.com)

© COPYRIGHT 2001 METRA ELECTRONICS CORPORATION

Rev.130103

# ALL VEHICLES

1

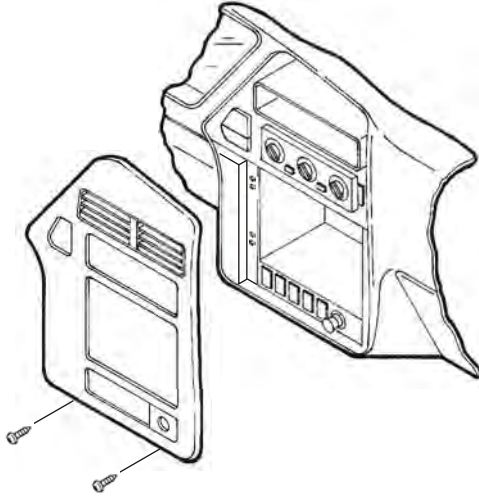

Disconnect the negative battery terminal to prevent an accidental short circuit. Remove (2) screws from the base of the radio trim bezel. Unclip the bottom edge of the radio trim bezel and disconnect the hazard light, defroster, wiper and cigarette lighter wiring. Remove the radio trim bezel. Remove (4) screws securing the factory head unit and disconnect the wiring.

2

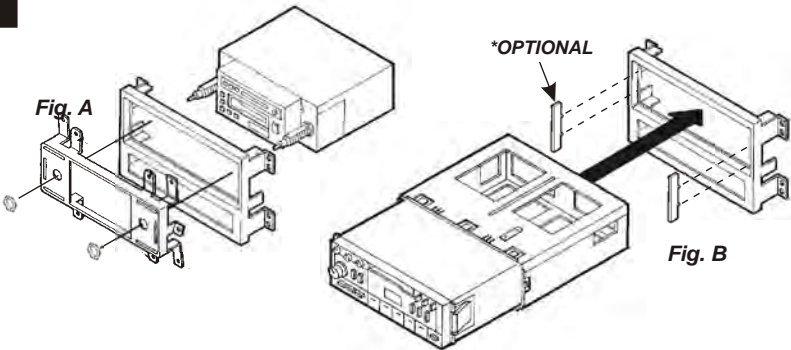

**2-SHAFT HEAD UNITS:** Attach the **Faceplate** to the **Radio Housing**. Slide the aftermarket head unit into the kit and secure with shaft nuts. (see Fig. A)

**DIN HEAD UNITS:** Attach the **Snap Spacers\*** to the inner walls of the **Radio Housing**. Slide the DIN cage into the kit and secure by bending the metal locking tabs down. Slide the aftermarket head unit into the cage until secure. (see Fig. B)

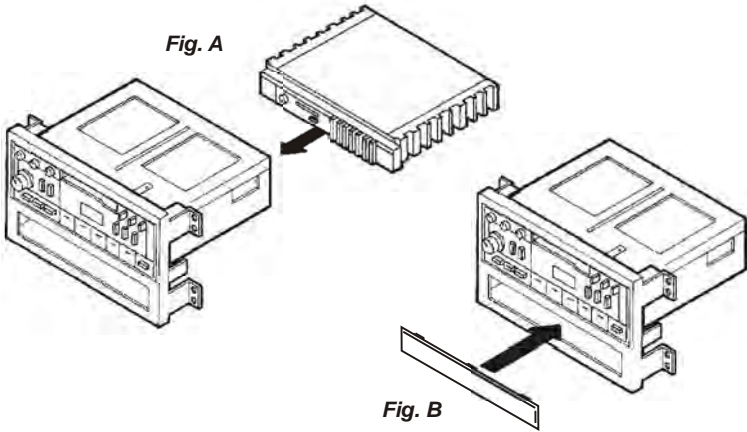
**3**

***IF AN EQUALIZER WILL BE INCLUDED:*** Slide the aftermarket equalizer into the back of the **Radio Housing**. Using the hardware included with the equalizer, mount the unit to the kit. (see Fig. A)

***IF AN EQUALIZER WILL NOT BE INCLUDED:*** Snap the **Equalizer Dummy Plate** into the **Radio Housing**. (see Fig. B)

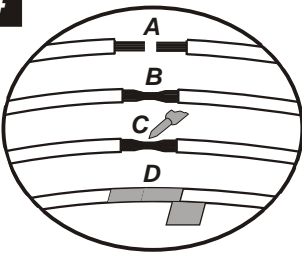
**4**

- A) Strip wire ends back ½"**
- B) Twist ends together**
- C) Solder**
- D) Tape**

Locate the factory wiring harness in the dash. Metra recommends using the proper mating adaptor and making connections as shown. (Isolate and individually tape off the ends of any unused wires to prevent electrical short circuit).

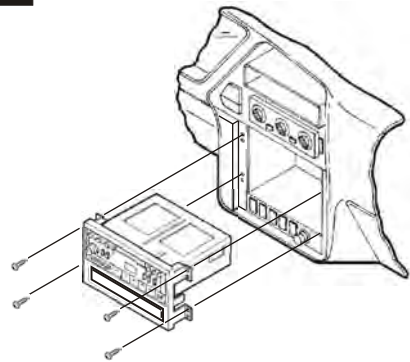
**5**

Re-connect the battery terminal and test the unit for proper operation. Mount the head unit/kit assembly to the sub-dash with (4) screws previously removed in step #1.