



INSTALLATION INSTRUCTIONS FOR PART 99-7606

APPLICATIONS

Nissan Titan

(With Dual Zone Climate Controls) 2006-07

Nissan Pathfinder Armada 2006-07

99-7606

KIT FEATURES

- DIN Radio Provision with pocket
- ISO Radio Unit Provision with pocket
- Double DIN Radio Provision
- Stacked ISO Head Units Provision



KIT COMPONENTS

- A) Radio Housing • B) ISO Brackets • C) ISO Trim Plate • D) Double DIN Brackets • E) Double DIN Trim Plate
 • F) Pocket • G) (6) Panel Clips • H) Two Sided Tape (Not Shown)

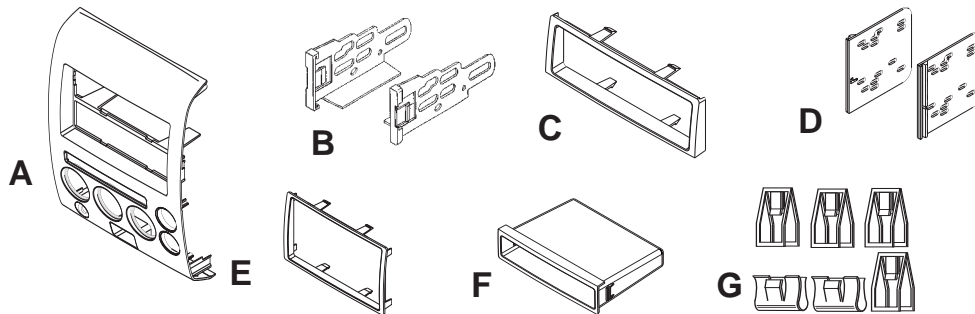

TOOLS REQUIRED:

- Torx T-10 Driver • Small Flat Blade Screwdriver • Phillips Screwdriver
 Or Panel Removal Tool



1-800-221-0932



www.metraonline.com

© COPYRIGHT 2004-2008 METRA ELECTRONICS CORPORATION



TABLE OF CONTENTS

• Dash Disassembly

- Nissan Titan 2006 -071, 2**
- Nissan Pathfinder Armada 2006-07.....1, 2**

• Kit Assembly:

- Pre-Kit Assembly.....3**
- DIN Radio Provision with Pocket4**
- ISO Radio Provision with Pocket5**
- Double DIN Radio Provision6**
- Stacked ISO Head Units Provision7**

- Final Assembly8**

NISSAN TITAN 2006-07
NISSAN PATHFINDER ARMADA 2006-07

- 1 Disconnect the negative battery terminal to prevent an accidental short circuit.
- 2 Unclip and remove entire panel including radio and climate controls. (Figure A)
- 3 Remove (4) Phillips screws to remove radio from sub-dash. (Figure B)
- 4 Unsnap and remove the outer trim rings around a/c control knobs. (Figure C)

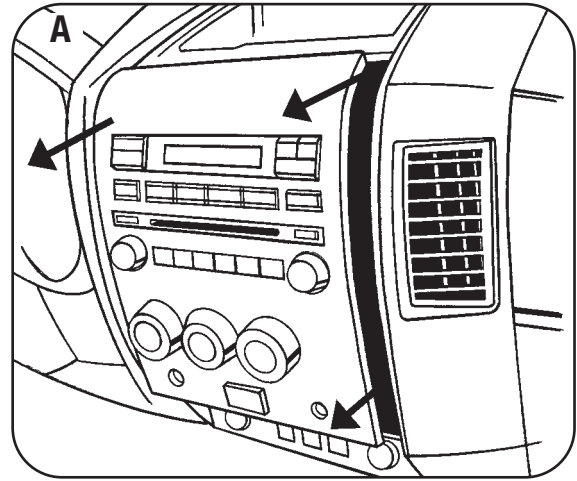

NOTE: The small round Airbag sticker also needs to be removed from the factory panel and placed onto the 99-7606 radio housing panel. (A round piece of double-sided tape is provided in case the factory sticker is not strong enough.) (Figure C)

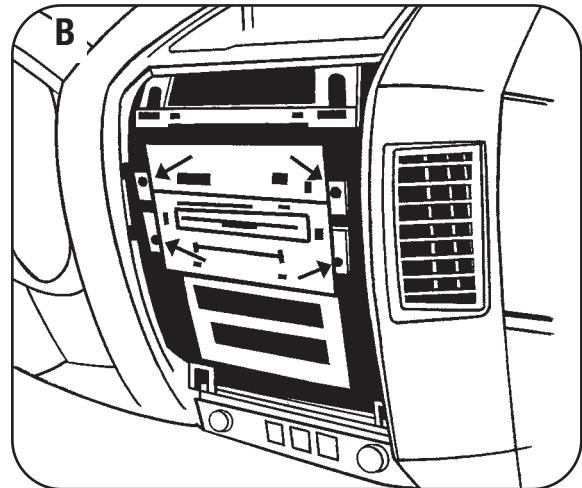

- 5 Remove (4) T-10 Torx screws from the a/c controls to remove from the factory radio trim panel. (Figure D)

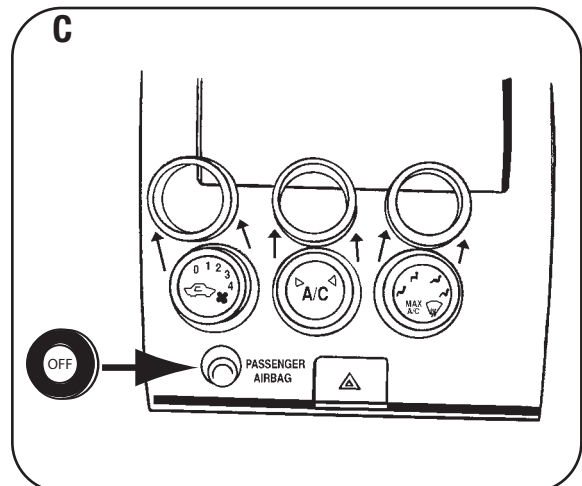

Continued on next page.



NISSAN TITAN 2006-07
NISSAN PATHFINDER ARMADA 2006-07

6 Unclip and remove the Hazard Light switch assembly. (Figure D)

7 Remove (2) T10 Torx screws from the passenger air bag off light assembly and remove. (Figure D)

Note: *The small round sticker also needs to be removed from the factory panel and placed onto the 99-7606 radio housing.*

Continue to kit assembly.

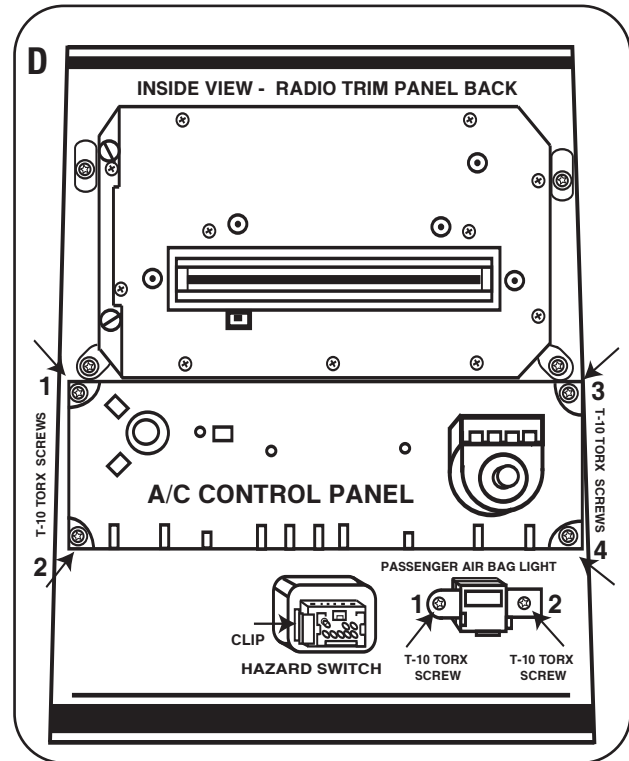

NISSAN TITAN 2006-07
NISSAN PATHFINDER ARMADA 2006-07

- 1** Attach the a/c control to the 99-7606 Radio Housing using the factory hardware removed in the dash dis-assembly. **(Figure A)**
- 2** Snap the outer trim rings onto the a/c control knobs. **(Figure B)**
- 3** Attach the passenger air bag off light assembly to the 99-7606 Radio Housing using the factory hardware removed in the dash disassembly. Also, apply to air bag button the small round airbag sticker previously removed in Step 4 dash disassembly. **(Figure C)**
- 4** Snap the hazard light switch into the 99-7606 Radio Housing. **(Figure D)**
- 5** Attach the (6) panel clips to the 99-7606 radio housing panel using the factory radio panel as a reference for clip positioning.

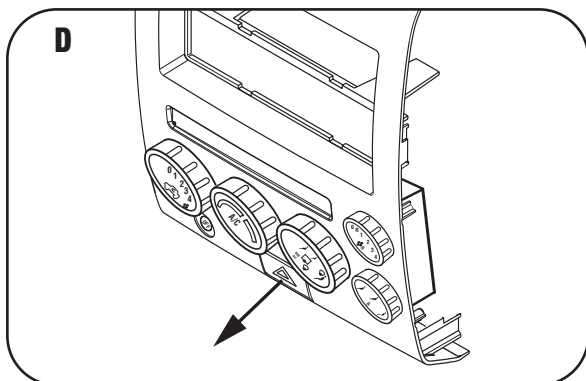
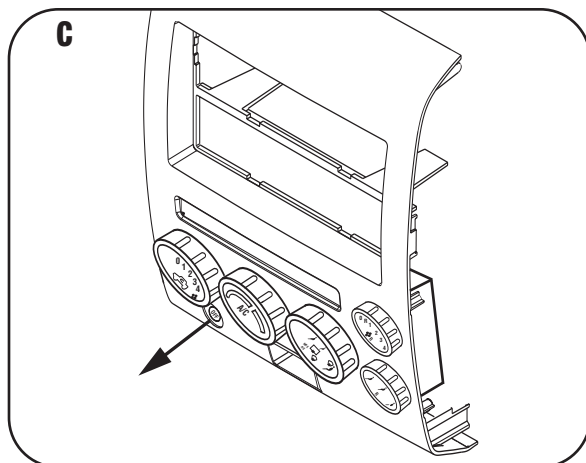
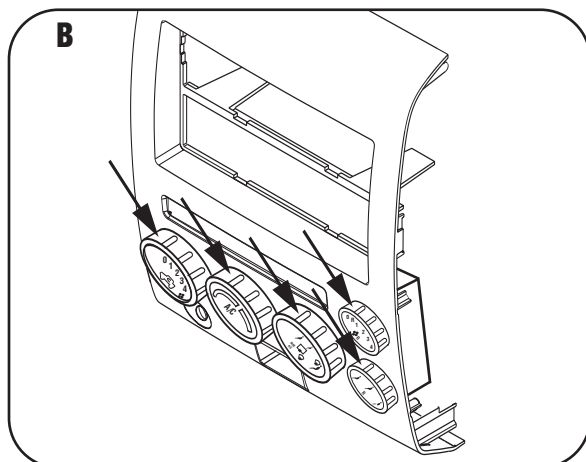
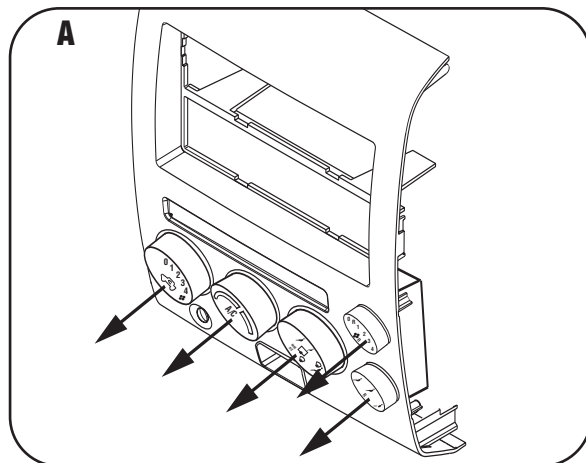

Continue to kit assembly.

DIN RADIO PROVISION WITH POCKET

- 1 Slide the DIN cage into the Radio Housing and secure by bending the metal locking tabs down. **(Figure A)**
- 2 Slide the aftermarket radio unit into the cage and secure. **(Figure B)**
- 3 Snap the pocket into the radio housing. **(Figure C)**

Continue to final assembly.

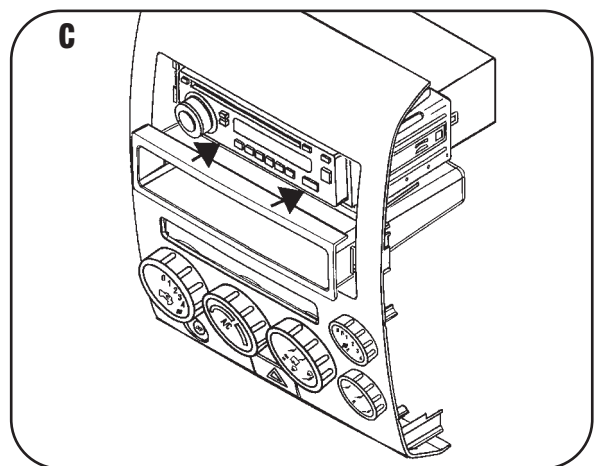
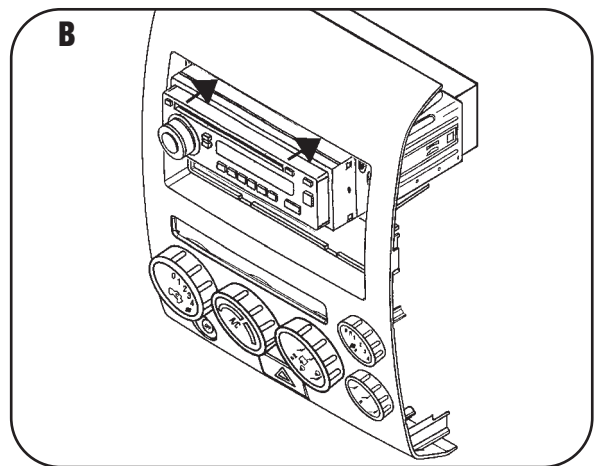
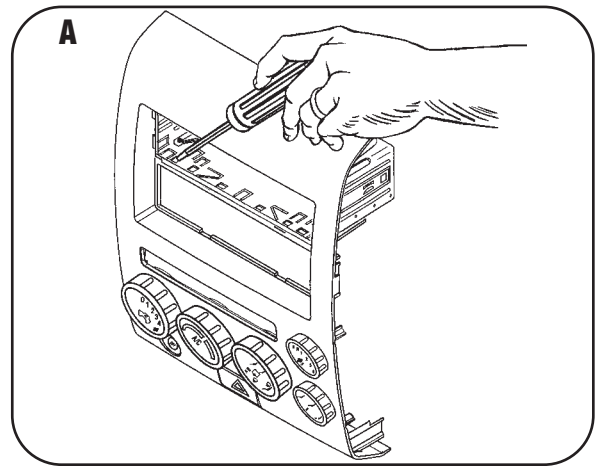

ISO RADIO PROVISION WITH POCKET

- 1 Mount the ISO Brackets to the radio with the screws supplied with the radio. **(Figure A)**
- 2 Slide the radio into the radio opening until the side clips engage. **(Figure B)**
- 3 Snap the Trim plate into the Radio Housing. **(Figure C)**
- 4 Snap the pocket into the radio housing. **(Figure D)**

Continue to final assembly.

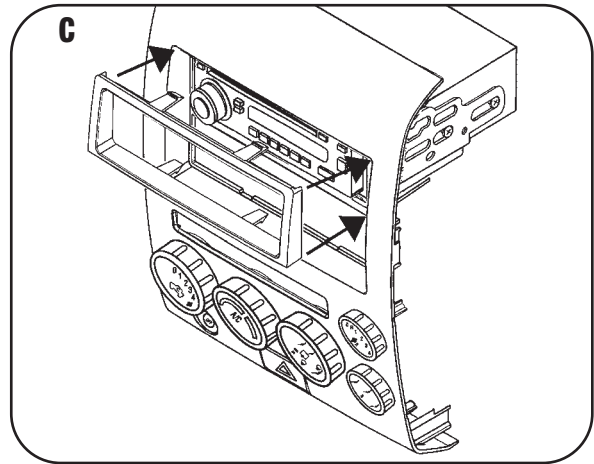
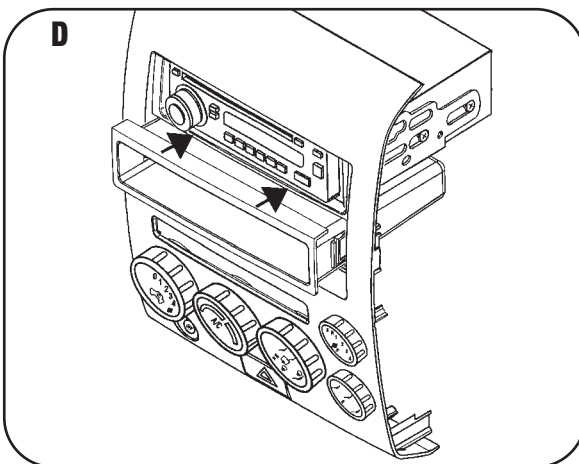
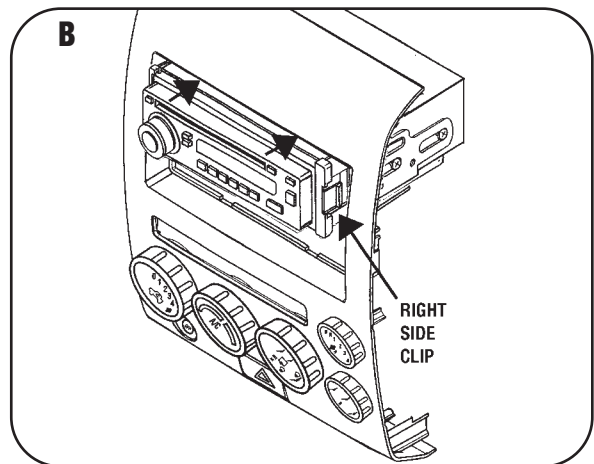
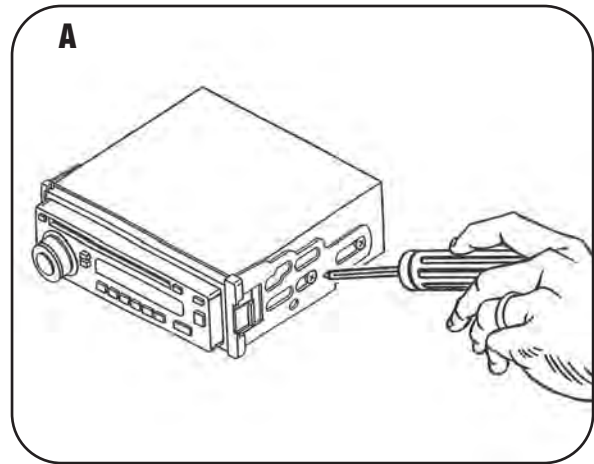

DOUBLE DIN RADIO UNIT PROVISION

- 1 Cut and remove center divider from radio housing. (Figure A)
- 2 Snap the Double DIN brackets to the inside edge of the radio housing. (Figure B)
- 3 Slide the Double DIN radio into the Double DIN bracket/radio housing assembly and secure the radio to the kit using the screws supplied with the head unit. (Figure C)
- 4 Snap the Double DIN trim plate onto the housing/radio assembly. (Figure C)

Continue to final assembly.

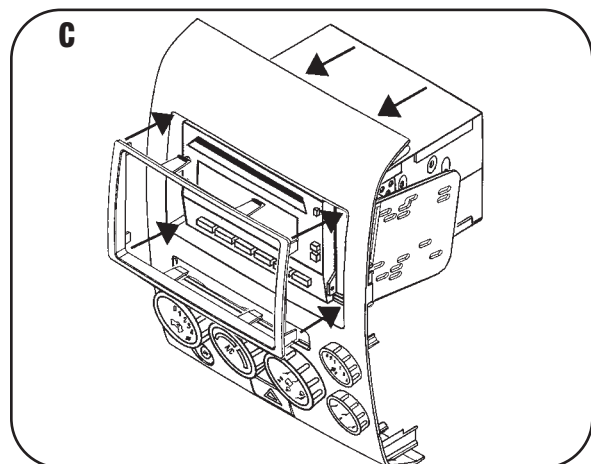
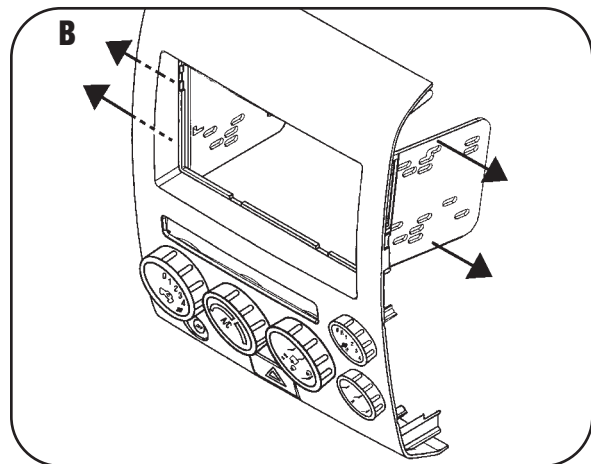
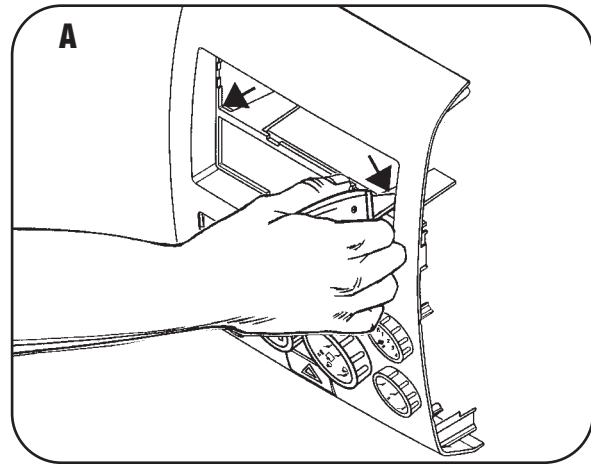

STACKED ISO HEAD UNITS PROVISION

- 1 Cut and remove center divider from radio housing. **(Figure A)**
- 2 Snap the Double DIN brackets to the inside edge of the radio housing. **(Figure B)**
- 3 Slide the stacked ISO units into the Double DIN bracket/radio housing assembly and secure the units to the kit using the screws supplied with the head units. **(Figure C)**
- 4 Snap the Double DIN trim-plate onto the housing/radio assembly. **(Figure C)**

Continue to final assembly.

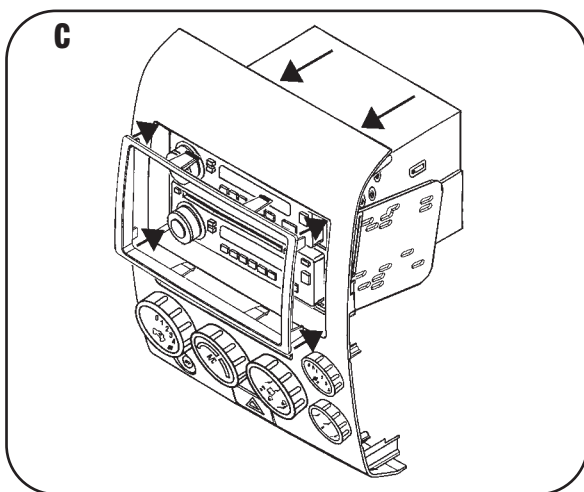
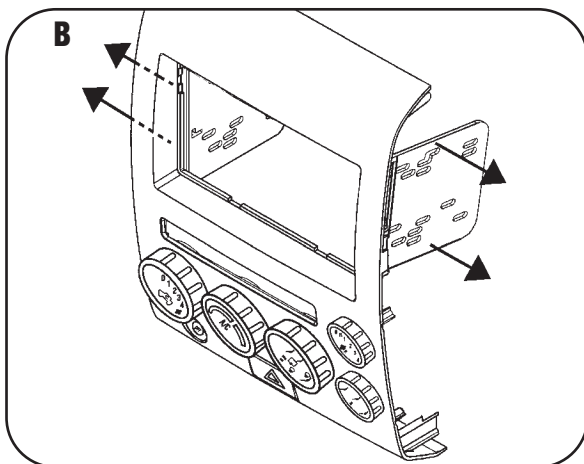
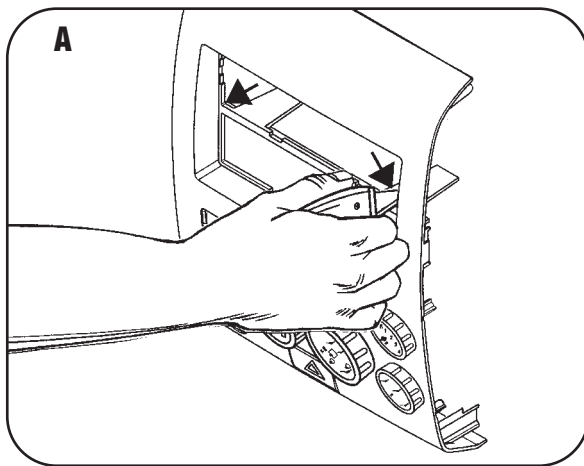

FINAL ASSEMBLY

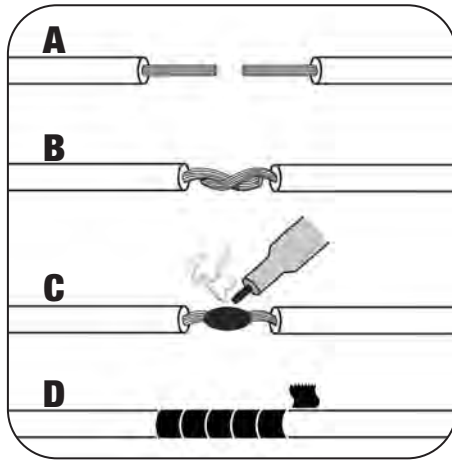

- A) Strip wire ends back 1/2"**
- B) Twist ends together**
- C) Solder**
- D) Tape**

- 1** Locate the factory wiring harness in the dash. Metra recommends using the proper mating adapter and making connections as shown. (Isolate and individually tape off the ends of any unused wires to prevent electrical short circuit.)
- 2** Re-connect the negative battery terminal and test the unit for proper operation.
- 3** Reassemble in reverse order of disassembly.

FINAL WIRING CONNECTIONS

Make wiring connections using the EIA color code chart shown below and the instructions included with the head unit. Metra recommends making connections as shown below; Strip, Splice, Solder, Tape. Isolate and individually tape off ends of any unused wires to prevent electrical short circuit.

METRA / EIA WIRING CODE

12V Ignition / Acc . . . Red	Right Front (+) Gray
12V Batt / Memory . . Yellow	Right Front (-) Gray/ Black
Ground Black*	Left Front (+) White
Power Antenna Blue	Left Front (-) White / Black
Amp Turn-On Blue / White	Right Rear (+) Violet
Amp Ground Black / White	Right Rear (-) Violet / Black
Illumination Orange	Left Rear (+) Green
Dimmer Orange / White	Left Rear (-) Green / Black

***NOTE:** When a Black wire is not present, ground radio to vehicle chassis.
All colors may not be present on all leads due to manufacturer's specifications.

99-7606 INSTRUCTIONS



1-800-221-0932



www.metraonline.com

REV. 02/22/08

© COPYRIGHT 2004-2008 METRA ELECTRONICS CORPORATION

INST99-7606