

KIT FEATURES

- ▶ Factory pocket provisions
- ▶ Equalizer provisions



99-7894

INSTALLATION INSTRUCTIONS

KIT COMPONENTS

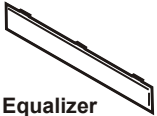
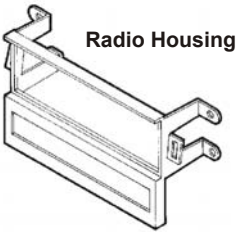

APPLICATIONS

CAR

PAGE

HONDA

Accord 1998-02.....	1-2
---------------------	-----



WIRING AND ANTENNA CONNECTIONS (Sold Separately)
Harness:

- 70-1721 - HONDA harness 1998-up

TOOLS REQUIRED



Phillips screwdriver



Cutting tool



KNOWLEDGE IS POWER

Enhance your installation and fabrication skills by enrolling in the most recognized and respected mobile electronics school in our industry. Log onto www.installerinstitute.com or call 800-354-6782 for more information and take steps toward a better tomorrow.



1-800-221-0932



www.metraonline.com

© COPYRIGHT 2001-09 METRA ELECTRONICS CORPORATION

REV. 07-30-09

ALL VEHICLES

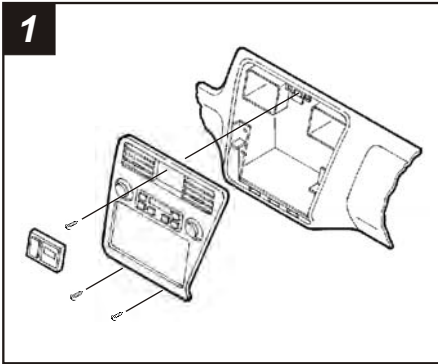

Disconnect the negative battery terminal to prevent an accidental short circuit. Unsnap the clock panel, disconnect the wiring and remove. Remove (1) Phillips screw exposed in the clock cavity. Remove (2) Phillips screws below the factory head unit. Unclip the radio trim bezel and disconnect the wiring. Remove (4) Phillips screws securing the factory head unit assembly and disconnect the wiring. Remove (2) screws securing the factory pocket to the assembly.

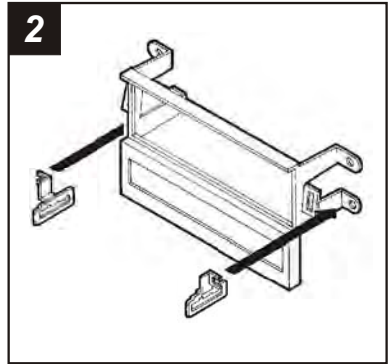

Snap the Brackets onto the front of the lower Housing.

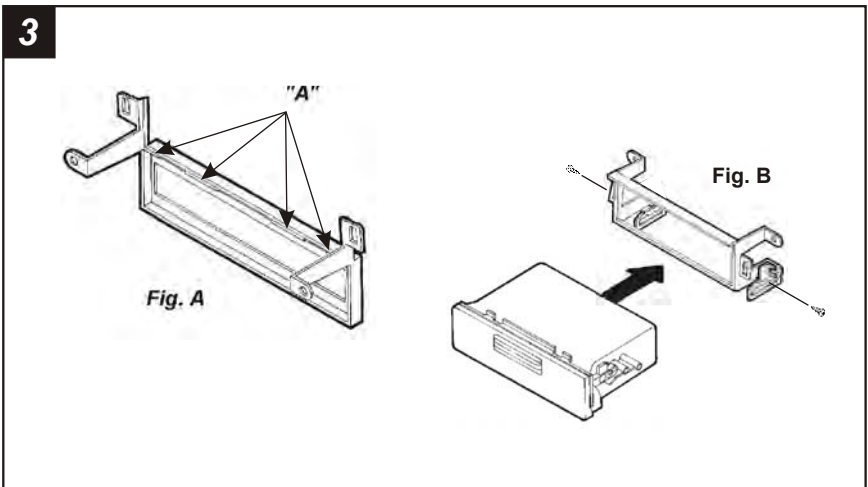

IF KEEPING THE FACTORY POCKET IS NOT DESIRED: Skip to step #4.

IF KEEPING THE FACTORY POCKET IS DESIRED: Cut sections "A" on the back of the Radio Housing and break away the bottom portion of the Housing. (see Fig. A). Mount the factory pocket to the Housing with (2) screws previously removed in step #1. (see Fig. B)

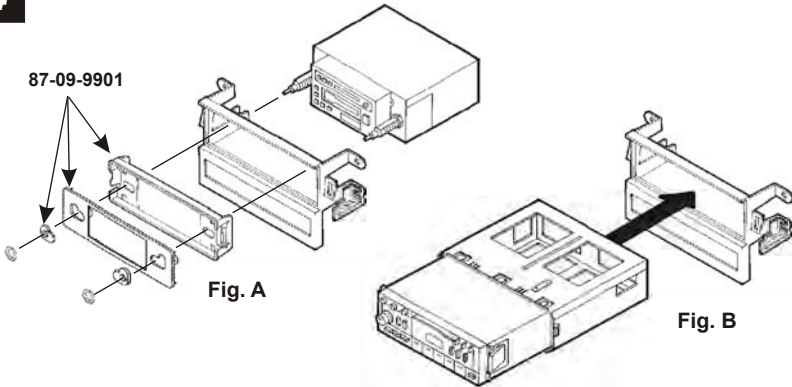
4

2-SHAFT HEAD UNITS: Order Metra's 87-09-9901 and snap it into the Radio Housing. Slide the aftermarket unit into the kit and secure with shaft nuts. (see Fig.A)

DIN HEAD UNITS: Slide the DIN cage into the kit and secure by bending the metal locking tabs down. Slide the aftermarket head unit into the cage until secure. (see Fig.B)

(If an equalizer will be included, slide the unit into the back of the Radio Housing and secure. If an equalizer will NOT be included, snap the Equalizer Dummy Plate into the opening).

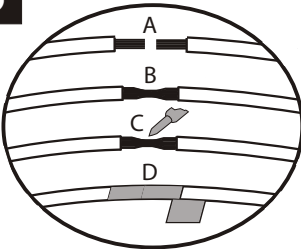
5

- A) Strip wire ends back 1/2"
- B) Twist ends together
- C) Solder
- D) Tape

Locate the factory wiring harness in the dash. Metra recommends using the proper mating adaptor and making connections as shown. (Isolate and individually tape off the ends of any unused wires to prevent electrical short circuit).

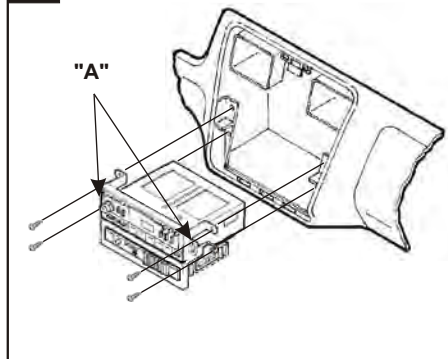
6

Re-connect the battery terminal and test the unit for proper operation. Mount the head unit/kit assembly to the sub-dash with (4) Phillips screws previously removed in step #1. Re-attach the radio trim bezel. Be sure the clips on the back of the bezel engage slots "A" on the kit.