

KIT FEATURES

- ▶ CD jewel case pocket



99-7895

INSTALLATION INSTRUCTIONS

KIT COMPONENTS

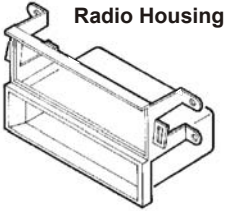

APPLICATIONS

CAR

PAGE

HONDA

Accord 1998-02.....1-2



TOOLS REQUIRED



Phillips screwdriver



1-800-221-0932



www.metraonline.com

© COPYRIGHT 2001-07 METRA ELECTRONICS CORPORATION

rev. 06-18-07

ALL VEHICLES

1

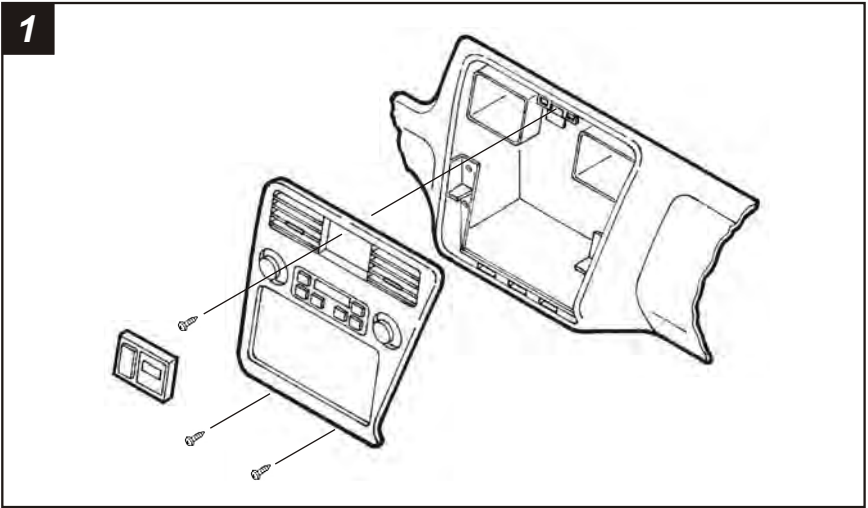

Disconnect the negative battery terminal to prevent an accidental short circuit. Unsnap the clock panel, disconnect the wiring and remove. Remove (1) Phillips screw exposed in the clock cavity. Remove (2) Phillips screws below the factory head unit. Unclip the radio trim bezel and disconnect the wiring. Remove (4) Phillips screws securing the factory head unit assembly and disconnect the wiring. Remove (2) screws securing the factory pocket to the assembly.

2

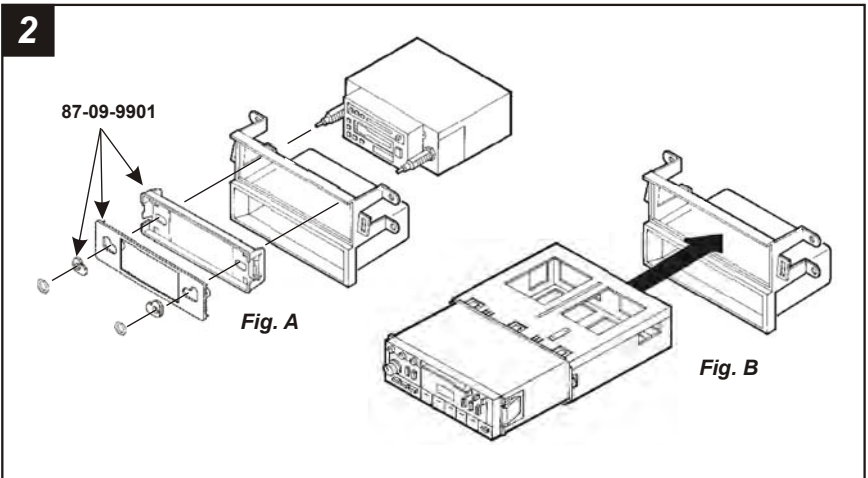

2-SHAFT HEAD UNITS: Order Metra's 87-09-9901 and snap it into the Radio Housing. Slide the aftermarket unit into the kit and secure with shaft nuts. (see Fig. A)

DIN HEAD UNITS: Slide the DIN cage into the kit and secure by bending the metal locking tabs down. Slide the aftermarket head unit into the cage until secure. (see Fig. B)

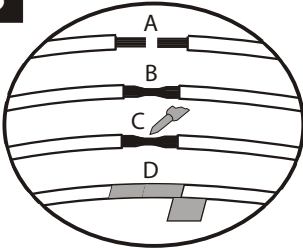
3

- A) Strip wire ends back ½"
- B) Twist ends together
- C) Solder
- D) Tape

Locate the factory wiring harness in the dash. Metra recommends using the proper mating adaptor and making connections as shown. (Isolate and individually tape off the ends of any unused wires to prevent electrical short circuit).

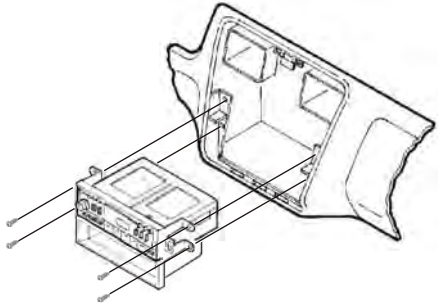
4

Re-connect the battery terminal and test the unit for proper operation. Mount the head unit/kit assembly to the sub-dash with (4) Phillips screws previously removed.

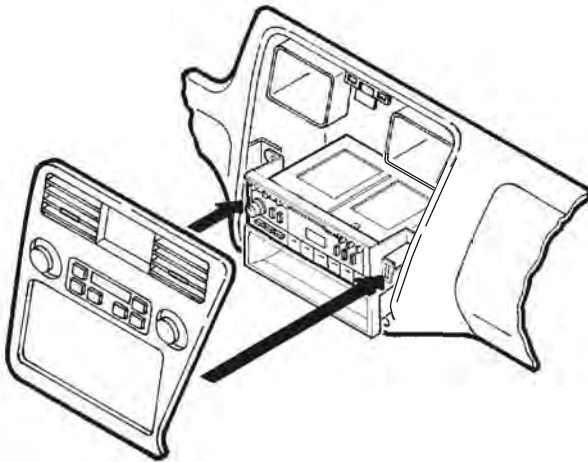
5

Re-attach the radio trim bezel. (Be sure the clips on the back of the bezel engage the slots on the kit).