

KIT FEATURES

- ▶ Shaft and DIN unit provisions
- ▶ Pocket provisions



99-7896

INSTALLATION INSTRUCTIONS

KIT COMPONENTS



APPLICATIONS

<u>CAR</u>	<u>PAGE</u>
HONDA	
Civic 1999-00.....	1-3

TOOLS REQUIRED



ALL VEHICLES

1

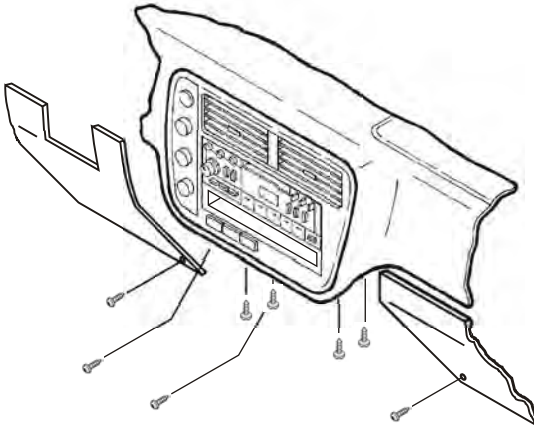

Disconnect the negative battery terminal to prevent an accidental short circuit. Remove (2) Phillips screws from the bottom edge of the glove box door and remove the door. Remove (3) Phillips screws from the lower steering column panel. Pull straight down on the lower steering column panel and remove the panel. Remove (2) Phillips screws under the climate controls. Remove (4) Phillips screws from the lower dash location. Remove (4) Phillips screws securing the bottom of the dash trim bezel/head unit assembly and pull the assembly out as far as possible. Cut the zip ties securing the head unit and climate control wires, slide the dash trim bezel/head unit assembly from the dash cavity and disconnect the wiring.

2

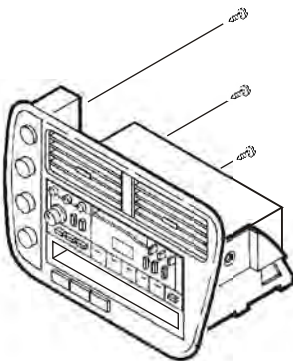

Remove (3) screws securing the climate control pod to the dash trim bezel and remove the pod.

3

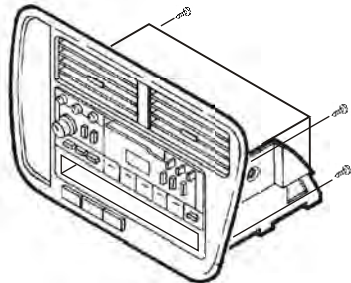

Remove (4) Phillips screws securing the head unit assembly to the back of the dash trim bezel.

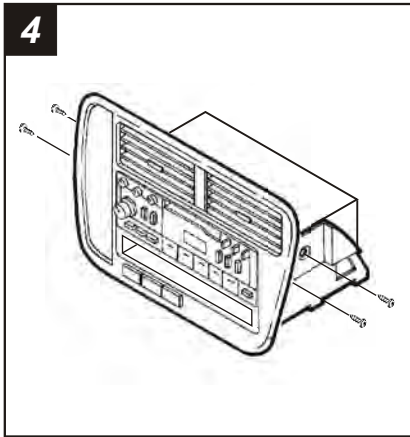

Remove (4) Phillips screws securing the factory brackets to the head unit assembly and slide the assembly out the front of the dash trim bezel.

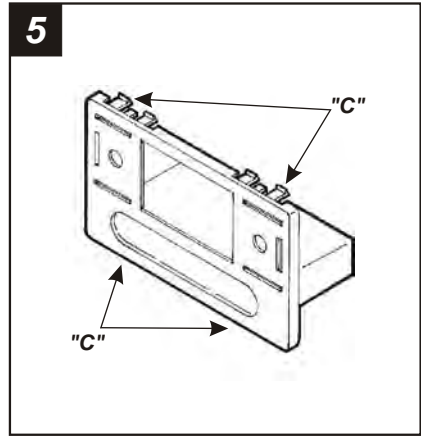

Cut and remove all mounting clips on the **Radio Housing** EXCEPT clips "C". The mounting clips can be identified by the stamped letter on each clip.

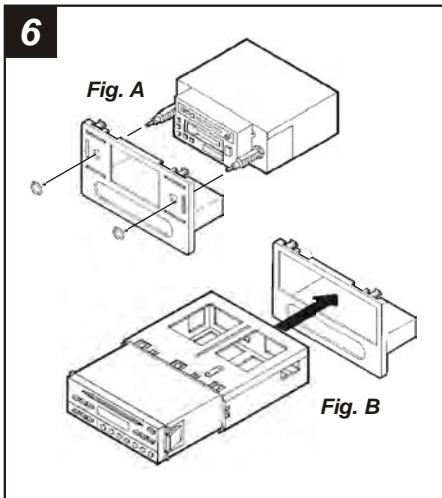

2-SHAFT HEAD UNITS: Slide the aftermarket head unit into the **Radio Housing** and secure with shaft nuts. (see Fig. A)

DIN HEAD UNITS: Cut and remove the shaft supports from the **Radio Housing**. Slide the DIN cage into the kit and secure by bending the metal locking tabs down. Slide the aftermarket head unit into the cage until secure. (see Fig. B)

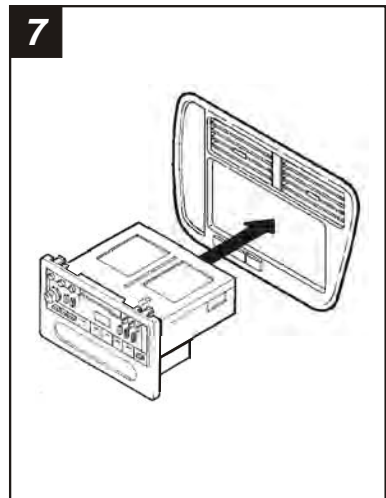

Snap the head unit/kit assembly into the radio trim bezel.

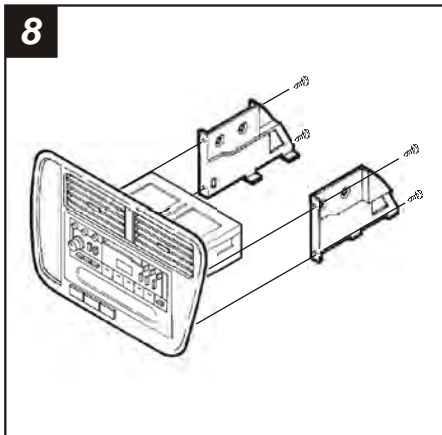

Mount the factory brackets to the back of the dash trim bezel with (4) Phillips screws previously removed in step #3.

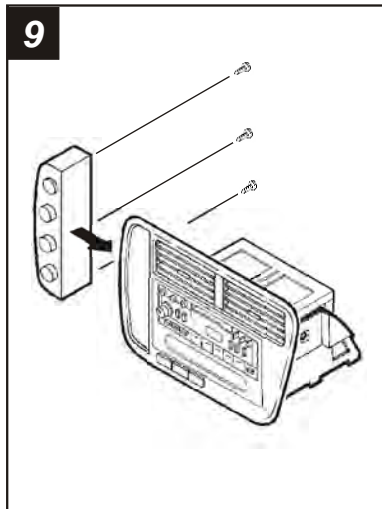

Mount the climate control pod to the dash trim bezel with (3) screws previously removed in step #2.

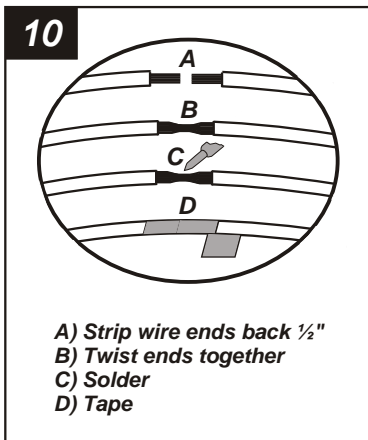

Locate the factory wiring harness in the dash. Metra recommends using the proper mating adaptor and making connections as shown. (Isolate and individually tape off the ends of any unused wires to prevent electrical short circuit).

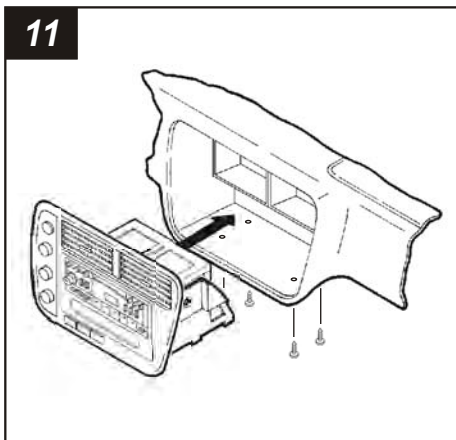

Re-connect the battery terminal and test the unit for proper operation. Slide the head unit/kit assembly into the sub-dash and mount with (4) Phillips screws previously removed in step #1.