



INSTALLATION INSTRUCTIONS FOR PART 99-7951

APPLICATIONS

CHEVROLET
Aveo 2004-2006
Aveo Hatchback-2007-2008

SUZUKI
Forenza 2004-2008
Reno 2005-2008

Verona 2004-2007
PONTIAC
G3 Hatchback-2007

99-7951

KIT FEATURES

- DIN Head Unit Provision with pocket
- ISO DIN Head Unit Provision with pocket



KIT COMPONENTS

A) Radio Housing • B) ISO Brackets • C) Trim Plate

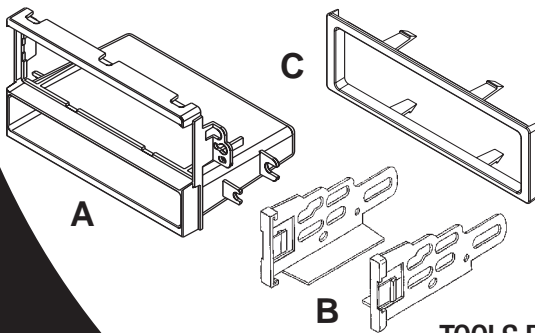

WIRING AND ANTENNA CONNECTIONS (Sold Separately)

Harness:

- **70-8405** - GM/Suzuki/Daewoo harness 1999-up

Antenna Adapter:

- Not required

TOOLS REQUIRED:

Phillips Screwdriver • Flat Blade Screwdriver Or Panel Removal Tool

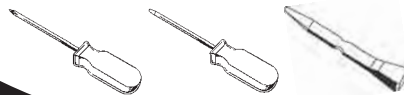

1-800-221-0932



www.metraonline.com

© COPYRIGHT 2004-2009 METRA ELECTRONICS CORPORATION

TABLE OF CONTENTS

• Dash Disassembly

- **Suzuki Verona 2004 - 2007 ----- 1**
- **Chevrolet Aveo 2004 - 2006 ----- 2**
- **Chevrolet Aveo Hatchback - 2007-2008----- 2**
- **Pontiac G3 Hatchback - 2007 ----- 2**

- **Suzuki Forenza 2004-2008 ----- 3**
- **Suzuki Reno 2005-2008 -----3**

•Kit Assembly

Chevrolet Aveo/Aveo Hatchback/Pontiac Hatchback/Suzuki Verona :

- **DIN Head Unit Provision with Pocket ----- 4**
- **ISO Head Unit Provision with Pocket ----- 5**

Suzuki Forenza /Suzuki Reno :

- **DIN Head Unit Provision with Pocket ----- 6**
- **ISO Head Unit Provision with Pocket ----- 7**

- Final Assembly ----- 8**



KNOWLEDGE IS POWER
Enhance your installation and fabrication skills
by enrolling in the most recognized and respected
mobile electronics school in our industry.
Log onto www.installerinstitute.com
or call 800-354-6782 for more information
and take steps toward a better tomorrow.

SUZUKI VERONA 2004 - 2007

- 1** Disconnect the negative battery terminal to prevent an accidental short circuit.
- 2** Unclip and remove the trim plate panel surrounding the radio. **(Figure A)**
- 3** Remove (4) Phillips screws holding radio to remove. **(Figure B)**

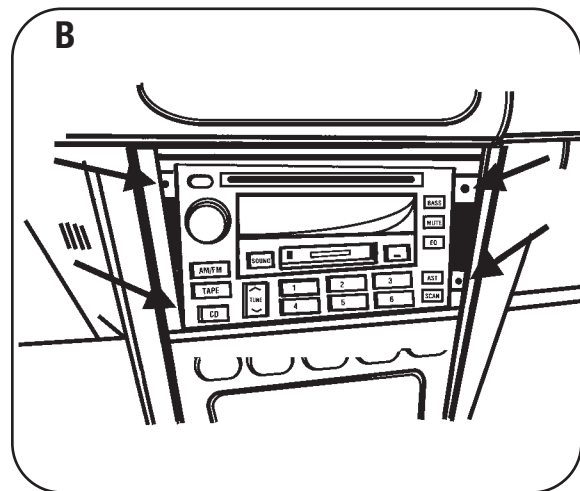
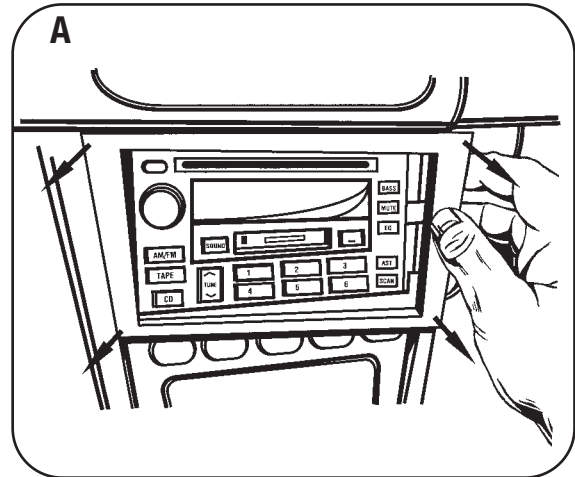

CHEVROLET AVEO 2004 - 2006
CHEVROLET AVEO HATCHBACK - 2007-2008
PONTIAC G3 HATCHBACK - 2007

- 1** Disconnect the negative battery terminal to prevent an accidental short circuit.
- 2** Unclip and remove the trim panels from both sides of radio/climate controls. (Figure A)
- 3** Remove (4) Phillips screws from radio to remove. (Figure B)

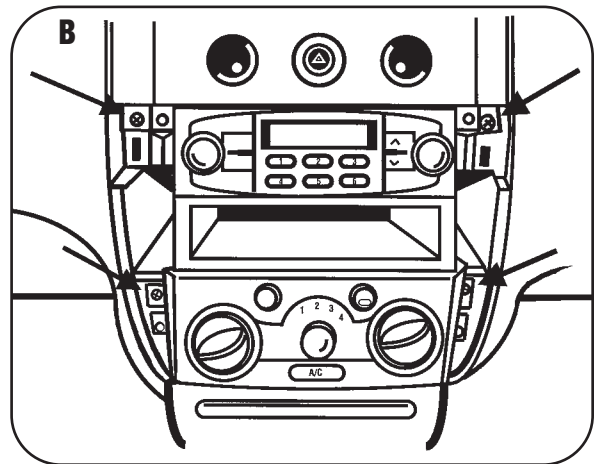
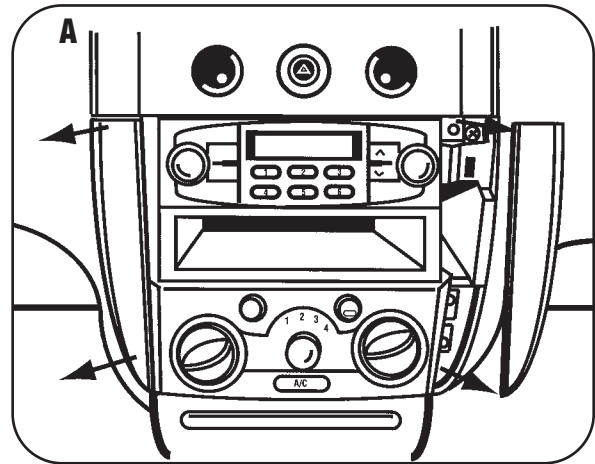

SUZUKI FORENZA 2004-2008 SUZUKI RENO 2005-2008

1 Disconnect air selector cable on drivers side of center console behind dash above accelerator pedal. **(Figure A & B)**

A

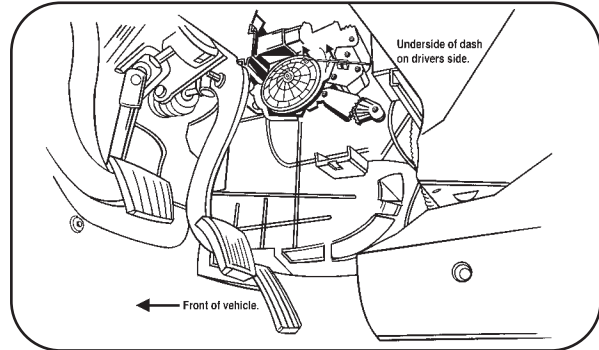

2 Open glove box and remove (5) Phillips screws ((3) on top and (2) on bottom) then remove entire glove.

B

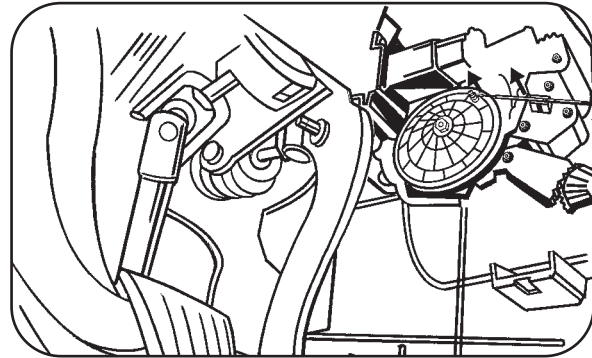

3 Disconnect temperature selector cable on passenger side of center console behind glove box. **(Figure C)**

C

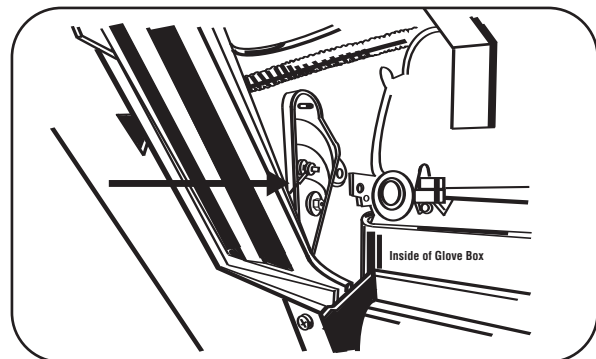

4 Unsnap and remove entire panel surrounding radio. Note: The clips holding radio panel to dash are very strong. **(Figure D)**

5 Remove (4) 10 MM bolts securing radio to remove. **(Figure E)**

D



E

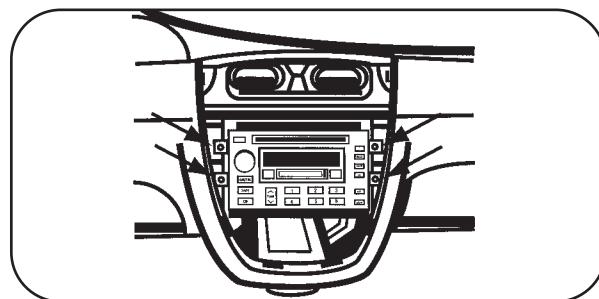

CHEVROLET AVEO 2004 - 2006
CHEVROLET AVEO HATCHBACK - 2007-2008
PONTIAC G3 HATCHBACK - 2007
SUZUKI VERONA 2004-2007
DIN HEAD UNIT PROVISION

- 1 Cut and remove front lower mounting tabs from radio housing. (Figure A)
- 2 Slide the DIN cage into the Radio Housing and secure by bending the metal locking tabs down. (Figure B)
- 3 Slide the aftermarket head unit into the cage and secure. (Figure C)

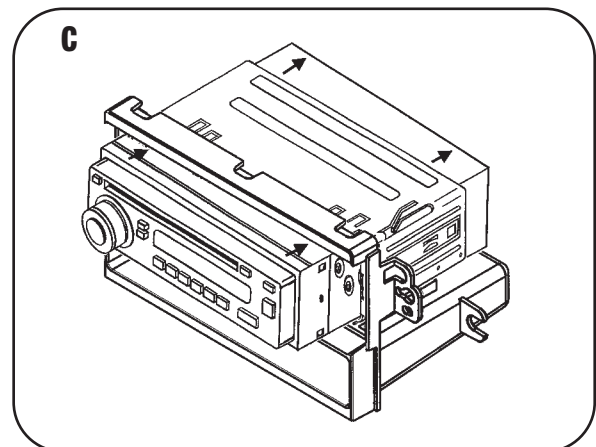
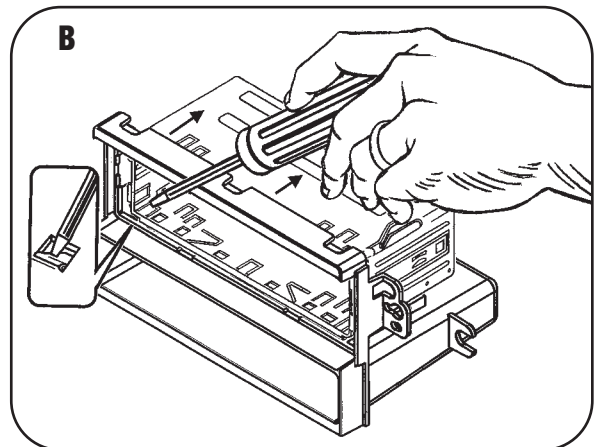
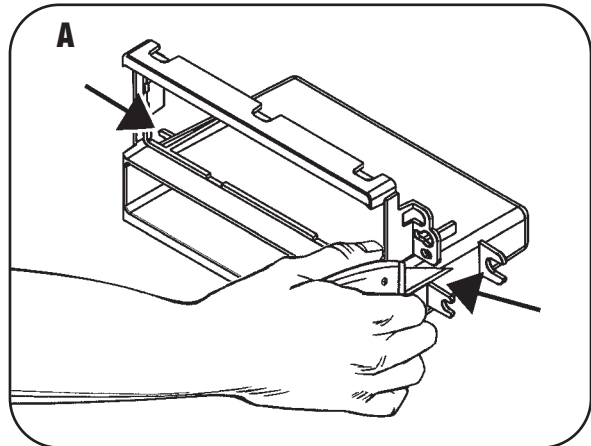

**CHEVROLET AVEO 2004 - 2006
CHEVROLET AVEO HATCHBACK - 2007-2008
PONTIAC G3 HATCHBACK - 2007
SUZUKI VERONA 2004-2007**

ISO DIN HEAD UNIT PROVISION

- 1** Cut and remove front lower mounting tabs from radio housing. **(Figure A)**
- 2** Mount the ISO Brackets to the head unit with the screws supplied with the unit. **(Figure B)**
- 3** Slide the head unit into the radio opening until the side clips engage. **(Figure C)**
- 4** Snap the Trim plate into the Radio Housing. **(Figure C)**

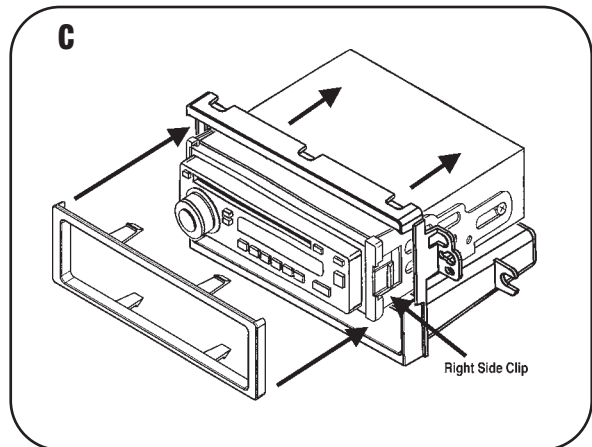
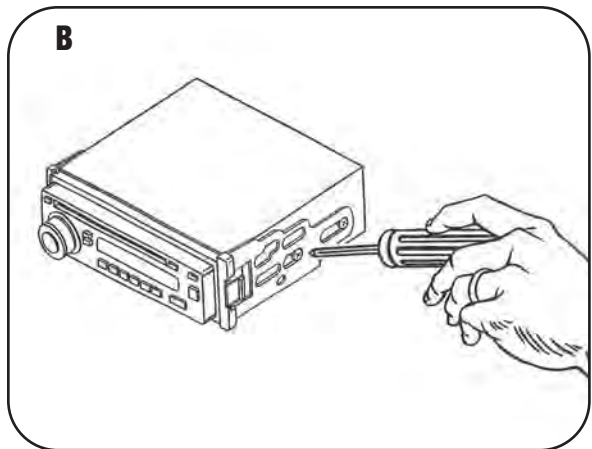
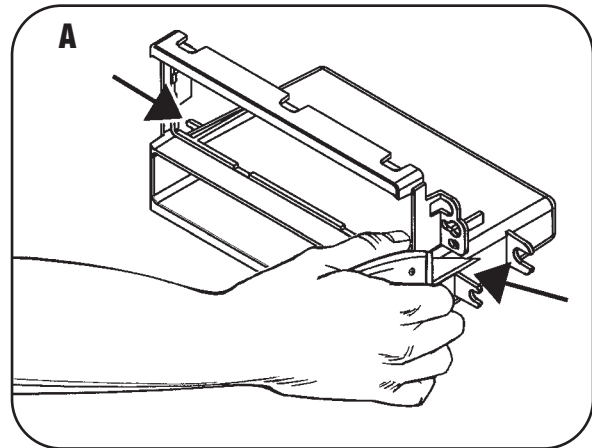

**SUZUKI FORENZA 2004-2008
SUZUKI RENO 2005-2008****DIN HEAD UNIT PROVISION WITH POCKET**

- 1** Cut and remove rear lower mounting tabs from radio housing. (Figure A)
- 2** Slide the DIN cage into the Radio Housing and secure by bending the metal locking tabs down. (Figure B)
- 3** Slide the aftermarket head unit into the cage and secure. (Figure C)

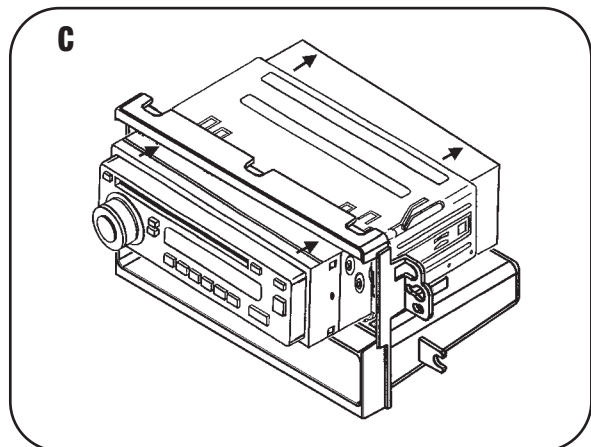
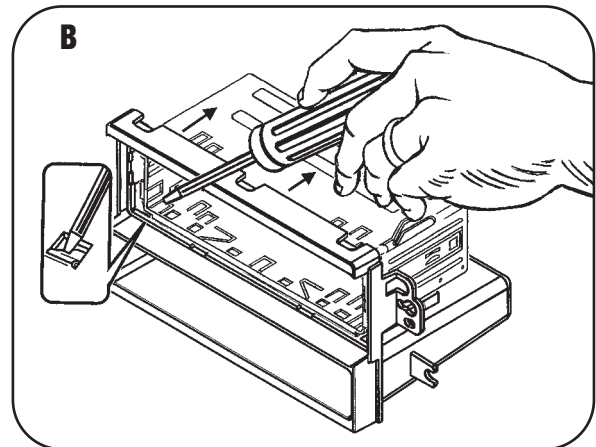
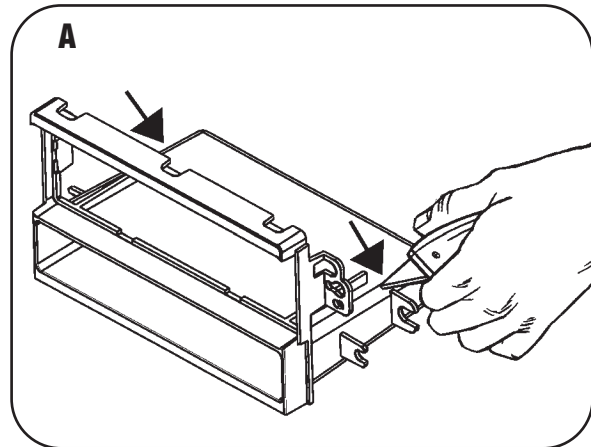

SUZUKI FORENZA 2004-2008 SUZUKI RENO 2005-2008

ISO DIN HEAD UNIT PROVISION

- 1** Cut and remove rear lower mounting tabs from radio housing. **(Figure A)**
- 2** Mount the ISO Brackets to the head unit with the screws supplied with the unit. **(Figure B)**
- 3** Slide the head unit into the radio opening until the side clips engage. **(Figure C)**
- 4** Snap the Trim plate into the Radio Housing. **(Figure C)**

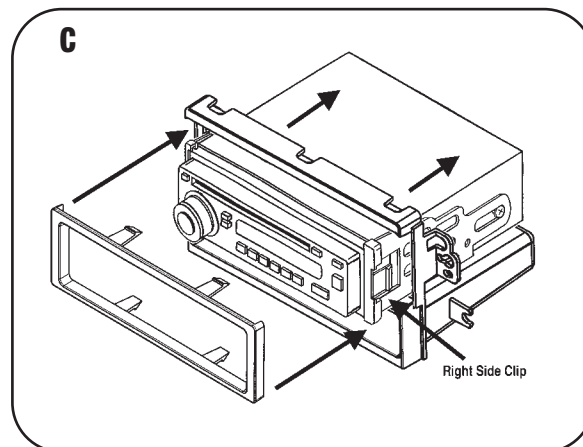
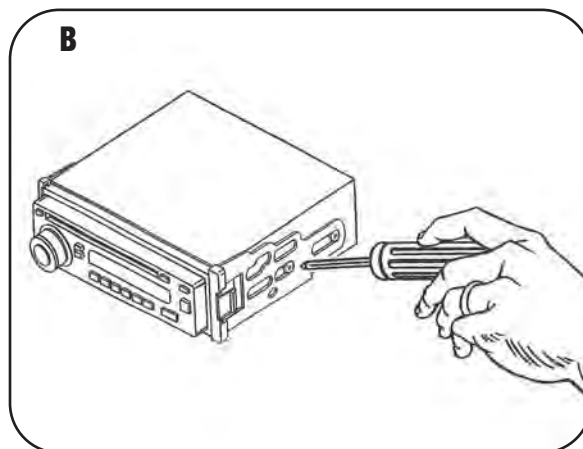
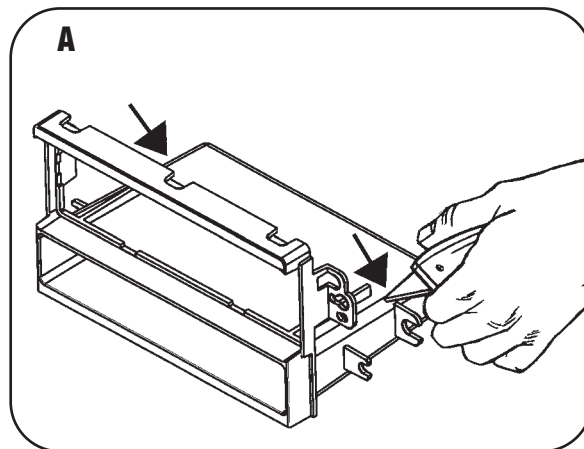

FINAL ASSEMBLY

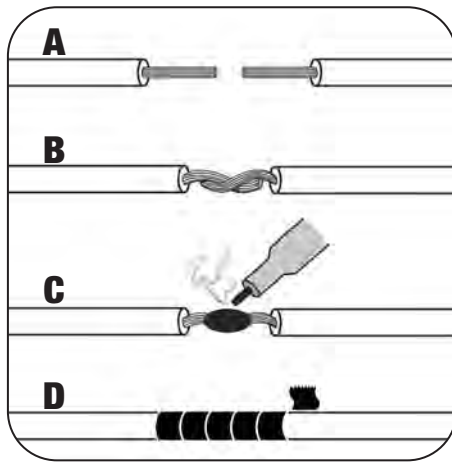

- A) Strip wire ends back 1/2"**
- B) Twist ends together**
- C) Solder**
- D) Tape**

- 1** Locate the factory wiring harness in the dash. Metra recommends using the proper mating adapter and making connections as shown. (Isolate and individually tape off the ends of any unused wires to prevent electrical short circuit.)
- 2** Re-connect the negative battery terminal and test the unit for proper operation.
- 3** Snap radio housing assembly into factory radio opening.

FINAL WIRING CONNECTIONS

Make wiring connections using the EIA color code chart shown below and the instructions included with the head unit. Metra recommends making connections as shown below; Strip, Splice, Solder, Tape. Isolate and individually tape off ends of any unused wires to prevent electrical short circuit.

METRA / EIA WIRING CODE

12V Ignition / Acc . . . Red	Right Front (+) Gray
12V Batt / Memory . . Yellow	Right Front (-) Gray/ Black
Ground Black*	Left Front (+) White
Power Antenna Blue	Left Front (-) White / Black
Amp Turn-On Blue / White	Right Rear (+) Violet
Amp Ground Black / White	Right Rear (-) Violet / Black
Illumination Orange	Left Rear (+) Green
Dimmer Orange / White	Left Rear (-) Green / Black

***NOTE:** When a Black wire is not present, ground radio to vehicle chassis.
All colors may not be present on all leads due to manufacturer's specifications.

99-7951 INSTRUCTIONS



1-800-221-0932



www.metraonline.com

REV. 07/09/09

© COPYRIGHT 2004-2009 METRA ELECTRONICS CORPORATION

INST99-7951