



INSTALLATION INSTRUCTIONS FOR PART 99-7954

APPLICATIONS

SUZUKI SX4 2007-2008

99-7954

KIT FEATURES

- DIN Radio Provision with Pocket
- ISO Mount Radio Provision with Pocket
- Double DIN Radio Provision
- Stacked ISO Units Provision



KIT COMPONENTS

- A) Radio Housing • B) ISO Brackets • C) ISO Trim Plate • D) Pocket • E) Double DIN Brackets
• F) Double DIN Trim Plate

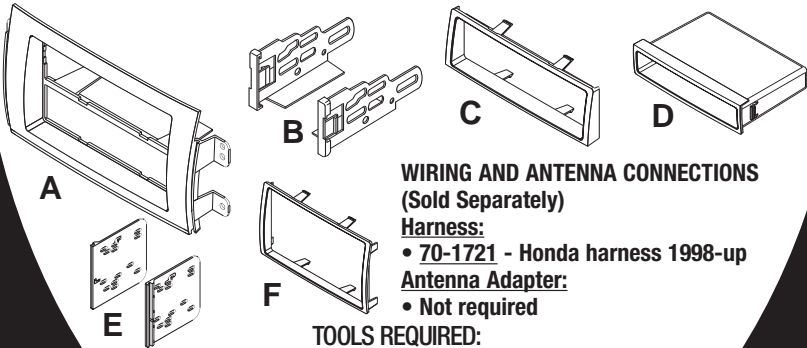

TOOLS REQUIRED:

- Flat Blade Screwdriver/ Panel Removal Tool
• Phillips Screwdriver



1-800-221-0932



www.metraonline.com

© COPYRIGHT 2007-2009 METRA ELECTRONICS CORPORATION

TABLE OF CONTENTS

Dash Disassembly

- SUZUKI SX4 2007 -2008 1

Kit Assembly

- DIN Radio Provision with Pocket 2
- ISO Mount Radio Provision with Pocket 3
- Double DIN Radio Provision 4
- Stacked ISO Units Provision 5

Final Assembly 6

***Note:**

Refer also to the instructions included with the aftermarket radio.



KNOWLEDGE IS POWER

Enhance your installation and fabrication skills by enrolling in the most recognized and respected mobile electronics school in our industry. Log onto www.installerinstitute.com or call 800-354-6782 for more information and take steps toward a better tomorrow.

SUZUKI SX4 2007-2008

- 1** Disconnect the negative battery terminal to prevent an accidental short circuit.
- 2** Unclip and remove the (2) outside trim panels. (Figure A)
- 3** Remove (4) Phillips screws securing the radio to the sub dash. Unplug and remove radio. (Figure B)

Continue to kit assembly.

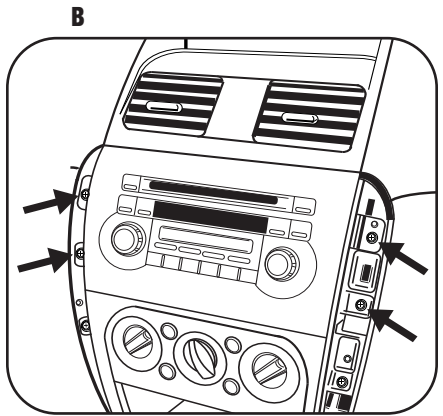
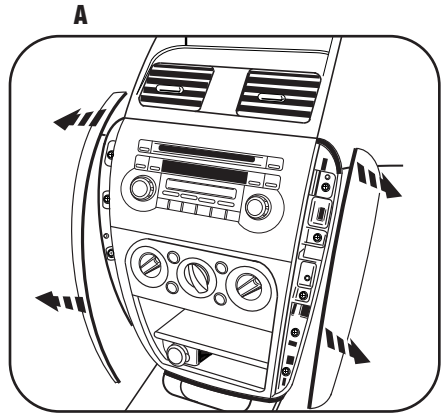

DIN RADIO PROVISION WITH POCKET

**Note: Refer also to the instructions included with the aftermarket radio.*

- 1 Slide the DIN cage into the Radio Housing and secure by bending the metal locking tabs outward. (Figure A)
- 2 Slide the aftermarket radio into the cage until it snaps into place. (Figure B)
- 3 Snap the pocket into the radio housing. (Figure C)

Continue to final assembly.

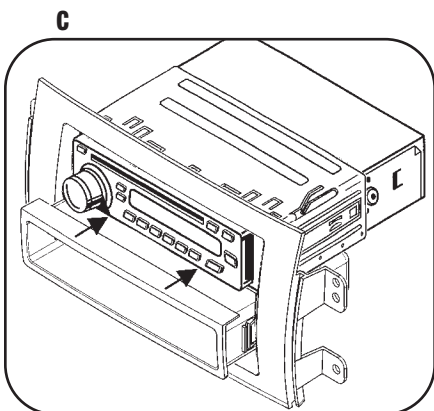
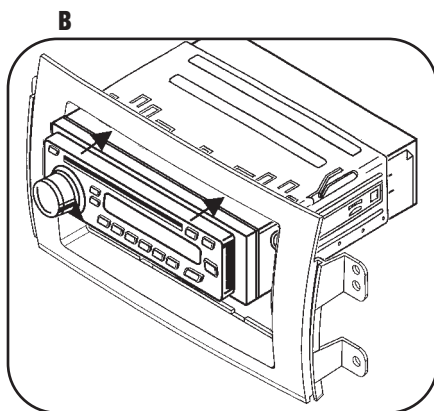
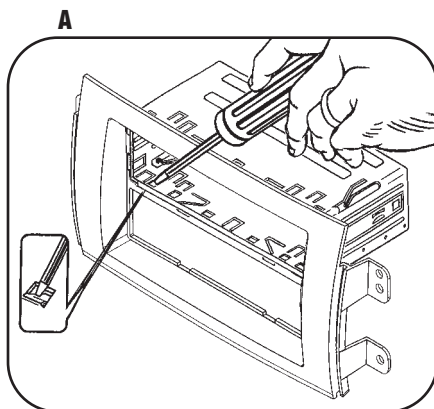

ISO MOUNT RADIO PROVISION WITH POCKET

**Note: Refer also to the instructions included with the aftermarket radio.*

- 1** Mount the ISO Brackets to the radio with the screws supplied with the radio. (Figure A)
- 2** Slide the radio into the radio housing until it snaps into place. (Figure B)
- 3** Snap the ISO trim plate onto the front of the Radio Housing. (Figure B)
- 4** Snap the pocket into the radio housing. (Figure C)

Continue to final assembly.

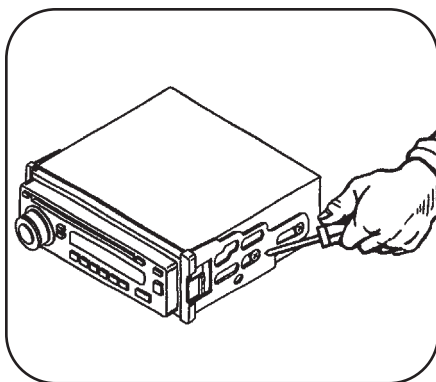
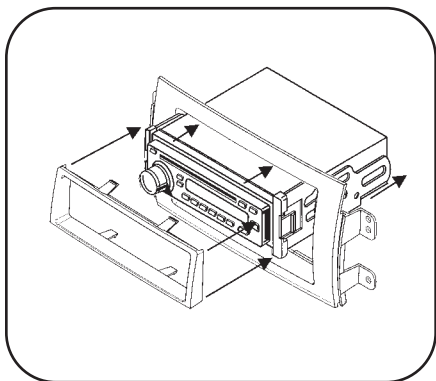
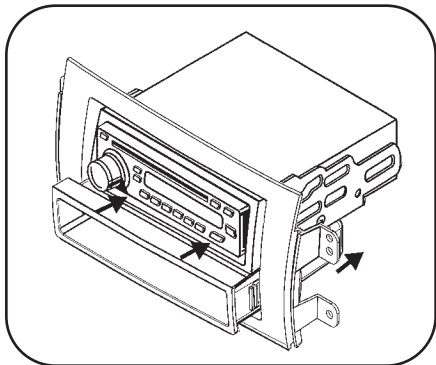
A

B

C

DOUBLE DIN RADIO PROVISION

**Note: Refer also to the instructions included with the aftermarket radio.*

- 1 Cut and remove the center bar from the radio housing. (Figure A)
- 2 Snap the Double DIN brackets to the inside edge of the radio housing. (Figure B)
- 3 Slide the Double DIN radio into the bracket/trim plate assembly and secure the radio to the assembly using the screws supplied with the radio. (Figure C)
- 4 Snap the Double DIN trim plate into the radio housing. (Figure C)

Continue to final assembly.

A

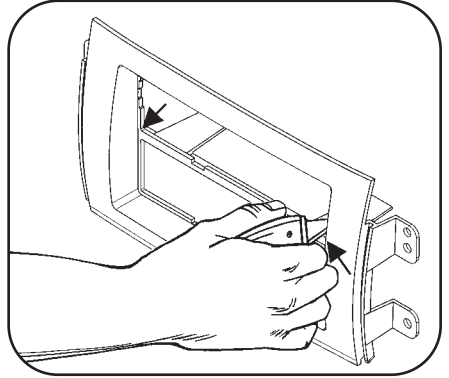

B

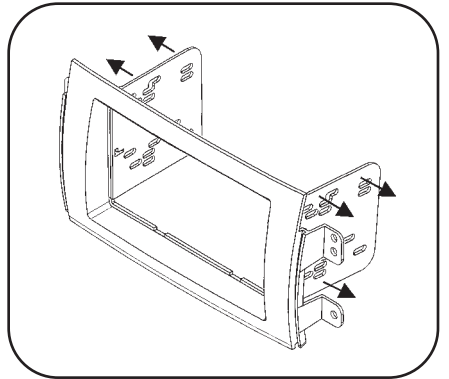

C

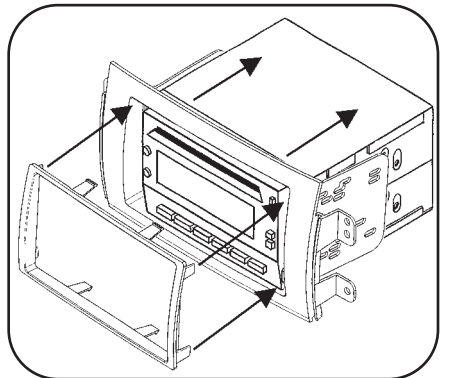

STACKED ISO UNITS PROVISION

**Note: Refer also to the instructions included with the aftermarket radio.*

- 1 Cut and remove the center bar from the radio housing. (Figure A)
- 2 Snap the Double DIN brackets to the inside edge of the radio housing. (Figure B)
- 3 Slide the stacked ISO units into the bracket/radio housing assembly and secure the units to the kit using the screws supplied with the units. (Figure C)
- 4 Snap the Double DIN trim plate into the radio housing. (Figure C)

Continue to final assembly.

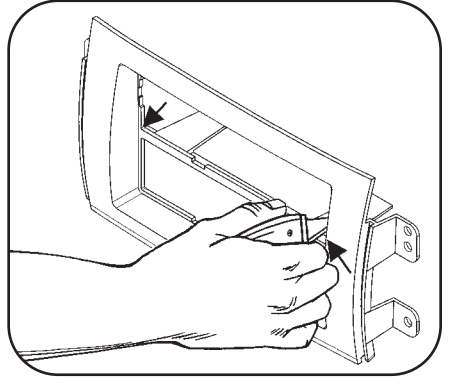
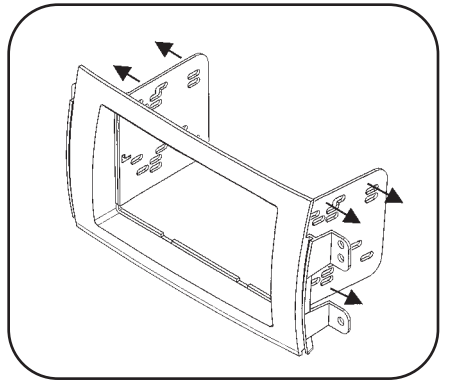
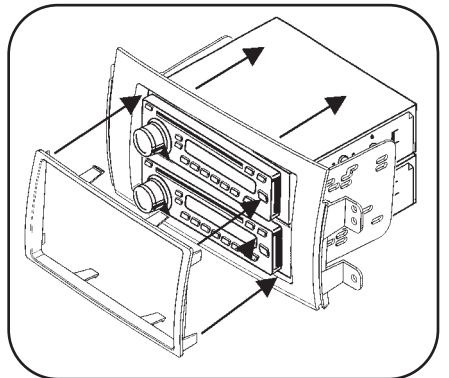
A**B****C**

FINAL ASSEMBLY

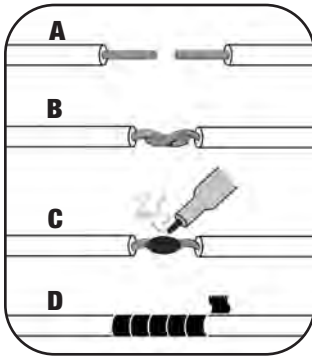

(A) Strip wire ends back 1/2"

B) Twist ends together

C) Solder

D) Tape

- 1** Locate the factory wiring harness in the dash. Metra recommends using the proper mating adapter and making connections as shown. (Isolate and individually tape off the ends of any unused wires to prevent electrical short circuit.)
- 2** Re-connect the negative battery terminal and test the unit for proper operation.
- 3** Reassemble radio and dash assemblies in reverse order of disassembly.

FINAL WIRING CONNECTIONS

Make wiring connections using the EIA color code chart shown below and the instructions included with the head unit. Metra recommends making connections as shown below; Strip, Splice, Solder, Tape. Isolate and individually tape off ends of any unused wires to prevent electrical short circuit.

METRA / EIA WIRING CODE

12V Ignition / Acc. Red	Right Front (+) Gray
12V Batt / Memory Yellow	Right Front (-) Gray/ Black
Ground Black*	Left Front (+) White
Power Antenna Blue	Left Front (-) White / Black
Amp Turn-On Blue / White	Right Rear (+) Violet
Amp Ground Black / White	Right Rear (-) Violet / Black
Illumination Orange	Left Rear (+) Green
Dimmer Orange / White	Left Rear (-) Green / Black

***NOTE:** When a Black wire is not present, ground radio to vehicle chassis.

All colors may not be present on all leads due to manufacturer's specifications.



1-800-221-0932



www.metraonline.com