



INSTALLATION INSTRUCTIONS FOR PART 99-8204

APPLICATIONS

2003-2008 Toyota Corolla

99-8204



KIT FEATURES

- DDIN Head Unit Provision with Pocket
- ISO DIN Head Unit Provision with Pocket

KIT COMPONENTS

A) Radio Housing • B) Pocket • C) Trimplate • D) Mounting Brackets • E) ISO Brackets • F) Rear Support Bracket
G) (8) #8x3/8" Phillips Flat Head Screws • H) (4) #8x3/8" Phillips Pan Head Screws

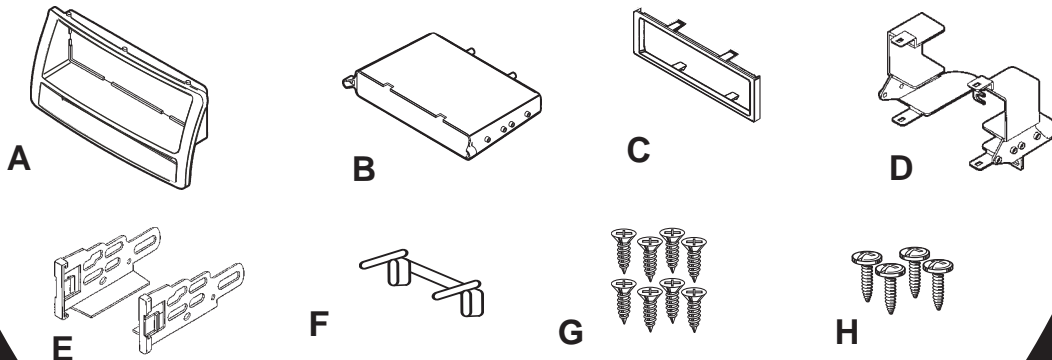

TOOLS REQUIRED:

Socket Wrench • Phillips Screwdriver

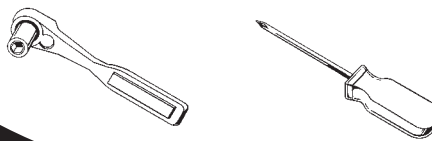

1-800-221-0932



www.metraonline.com

© COPYRIGHT 2004-2007 METRA ELECTRONICS CORPORATION



TABLE OF CONTENTS

Dash Disassembly 1

Kit Assembly 2-3

Final Assembly 4

2003-2008 TOYOTA COROLLA

Disconnect the negative battery terminal to prevent an accidental short circuit. Unsnap the gear shifter trim bezel and remove. Remove the center climate control knob and (1) Phillips screw exposed. Unclip the climate control bezel/pocket assembly and remove. Remove (4) 10 mm bolts from the bottom of the factory head unit. Remove the factory head unit/trim bezel assembly and disconnect the wiring. Unclip the bezel from the head unit and remove the unit.

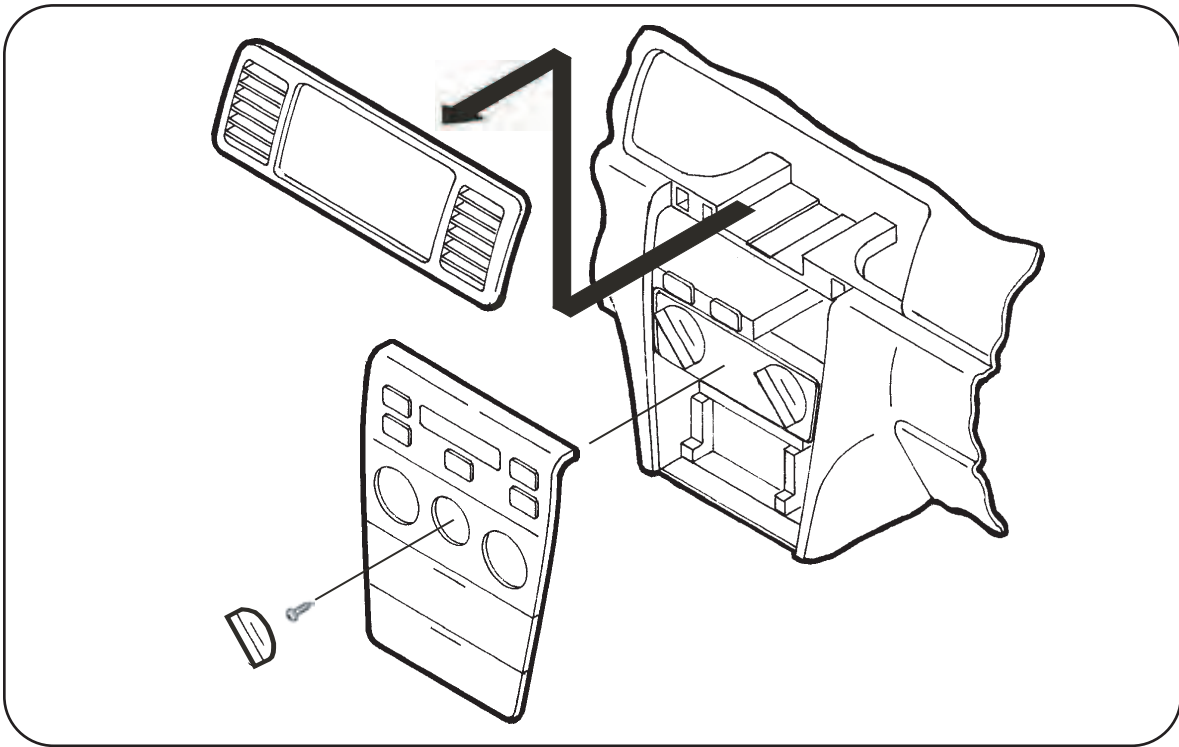

2003-2008 TOYOTA COROLLA

Attach the **Pocket** to the back of the **Radio Housing** (by holding the Housing upside-down, inserting the right edge of the Pocket into place and pushing the rest of the Pocket onto the lip) and mount with **(2) #8 x 3/8" Phillips Pan-head Screws** supplied. **Secure the Mounting Brackets** to the Pocket with **(8) #6 x 1/4" Phillip Flat-head Screws** supplied. Mount the **Rear Support Bracket** to the back of the Pocket with **(2) #8 x 3/8" Phillips Pan-head Screws** supplied.

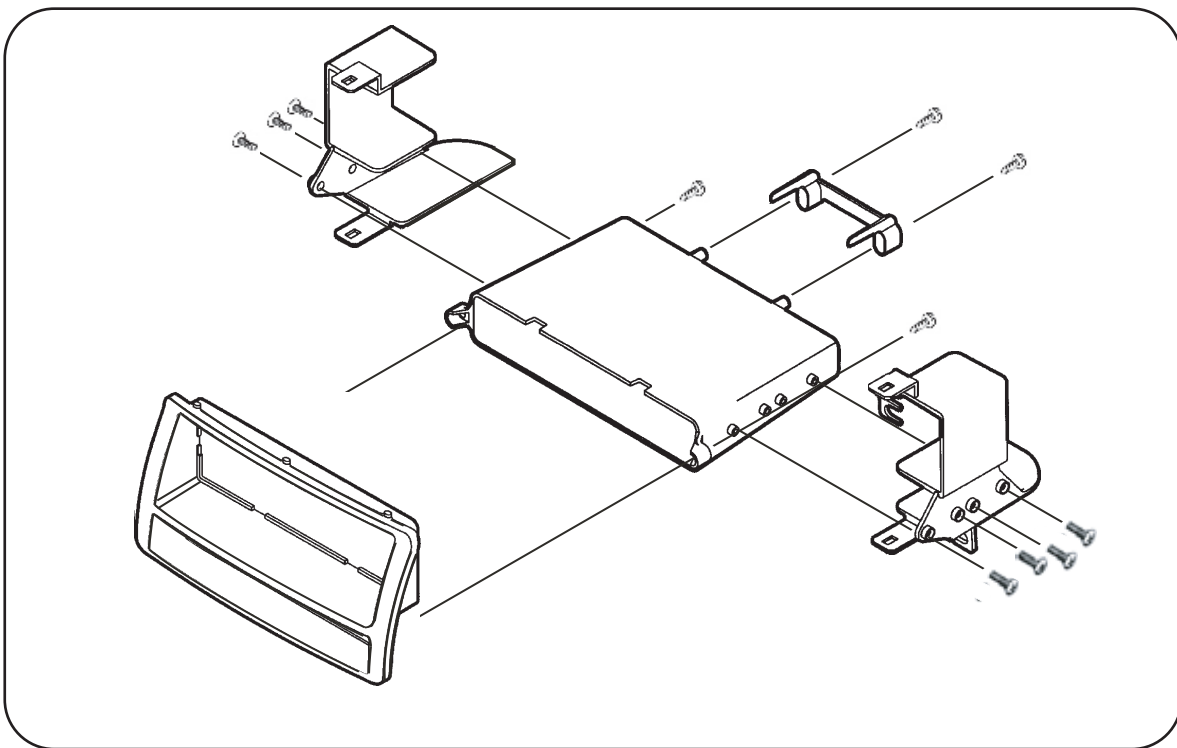

DIN HEAD UNIT PROVISION

- 1 Slide the DIN cage into the Radio Housing and secure by bending the metal locking tabs down. Slide the aftermarket head unit into the cage and secure.

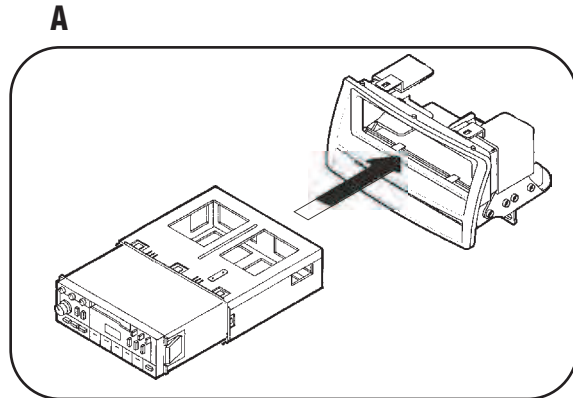

ISO DIN HEAD UNIT PROVISION

- 1 Align the holes in the ISO Brackets mount the Brackets to the head unit with the screws supplied with the unit. Slide the head unit/bracket assembly into the radio opening until the side clips engage and snap the Trimplate over the unit. (See Fig. B1)

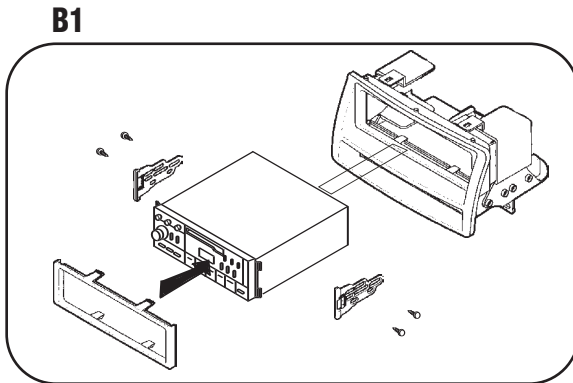

NOTE: To remove the mounted head unit, unclip and remove the ISO Trimplate. Using a small flat-blade screwdriver, disengage the side clips securing the ISO Brackets to the Radio Housing. (See Fig. B2)

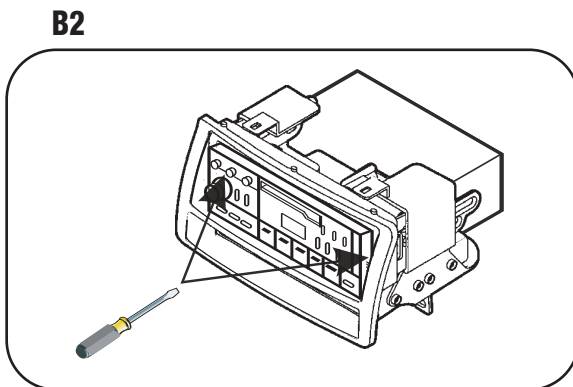

- 2 Re-connect the battery terminal and test the unit for proper operation. Snap the factory head unit trim bezel over the kit by engaging the (4) bracket tabs ("A") and (3) Housing bosses ("B") to the back of the bezel. Slide the assembly into the sub-dash and mount with (4) 10 mm bolts previously removed in step #1. Re-assemble the dash. (See Fig. B3)

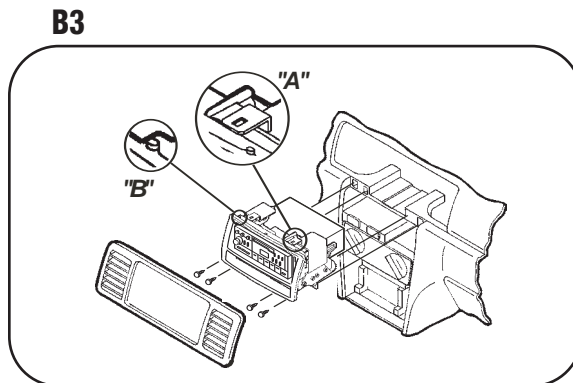

FINAL ASSEMBLY

- 1 Locate the factory wiring harness in the dash and make the connection as shown. Metra recommends using the proper mating adapter and making the connections as shown. (Isolate and individually tape off the ends of any unused wires to prevent electrical short circuit.)
- 2 Re-connect the negative battery terminal and test the unit for proper operation.
- 3 Reassemble radio and dash assemblies in reverse order of disassembly.

FINAL WIRING CONNECTIONS

Make wiring connections using the EIA color code chart shown below and the instructions included with the head unit. Metra recommends making connections as shown below; Strip, Splice, Solder, Tape. Isolate and individually tape off ends of any unused wires to prevent electrical short circuit.

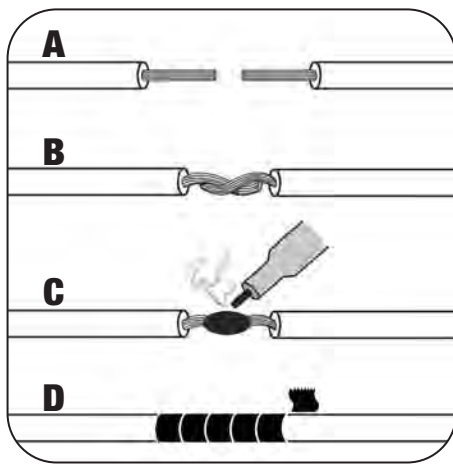

- A) Strip wire ends back 1/2"**
- B) Twist ends together**
- C) Solder**
- D) Tape**

METRA / EIA WIRING CODE

12V Ignition / Acc . . . Red	Right Front (+) Gray
12V Batt / Memory . . Yellow	Right Front (-) Gray / Black
Ground Black*	Left Front (+) White
Power Antenna Blue	Left Front (-) White / Black
Amp Turn-On Blue / White	Right Rear (+) Violet
Amp Ground Black / White	Right Rear (-) Violet / Black
Illumination Orange	Left Rear (+) Green
Dimmer Orange / White	Left Rear (-) Green / Black

***NOTE:** When Black a wire is not present, ground radio to vehicle chassis.

All colors may not be present on all leads due to manufacturer's specifications.

99-8204 INSTRUCTIONS



1-800-221-0932



www.metraonline.com

REV. 10/02/07

© COPYRIGHT 2004-2007 METRA ELECTRONICS CORPORATION

INST99-8204