



## INSTALLATION INSTRUCTIONS FOR PART 99-8209

### APPLICATIONS

#### SCION

**xA 2004-2006**

**xB 2004-2009**

**tC 2005-2009**

**xD 2008-2009**

# 99-8209



#### KIT FEATURES

- DIN Radio Provision with Pocket
- ISO Mount Radio Provision with Pocket

#### KIT COMPONENTS

A) Radio Housing • B) Brackets Set 1 • C) Brackets Set 2 • D) ISO Snap-In Brackets • E) Trim Plate

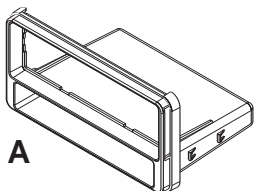

A

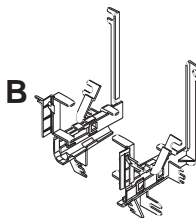

B

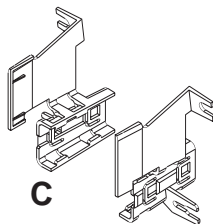

C

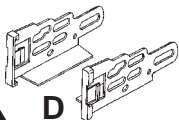

D

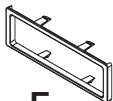

E

#### WIRING AND ANTENNA CONNECTIONS (Sold Separately)

- 70-1761 Toyota harness - 1987-up
- Antenna adapter - Not required

#### TOOLS REQUIRED:

Phillips Screwdriver • Panel Removal Tool • Socket Set



1-800-221-0932



[www.metraonline.com](http://www.metraonline.com)

© COPYRIGHT 2004-2009 METRA ELECTRONICS CORPORATION

## **TABLE OF CONTENTS**

### **Dash Disassembly**

<b>- SCION xA 2004-2006.....</b>	<b>1</b>
<b>- SCION xB 2004-2009.....</b>	<b>2</b>
<b>- SCION xB 2008 -2009.....</b>	<b>3</b>
<b>- SCION tC 2005-2009.....</b>	<b>4</b>
<b>- SCION xD 2008-2009.....</b>	<b>5</b>

### **Kit Assembly**

<b>- DIN Radio Provision with Pocket.....</b>	<b>6</b>
<b>- ISO Mount Radio Provision with Pocket.....</b>	<b>7</b>

<b><u>Final Assembly</u>.....</b>	<b>8</b>
-----------------------------------	----------

#### **\*Note:**

**Refer also to the instructions included with the aftermarket radio.**



### **KNOWLEDGE IS POWER**

Enhance your installation and fabrication skills by enrolling in the most recognized and respected mobile electronics school in our industry. Log onto [www.installerinstitute.com](http://www.installerinstitute.com) or call 800-354-6782 for more information and take steps toward a better tomorrow.

## Scion xA 2004-2006

- 1** Disconnect the negative battery terminal to prevent an accidental short circuit.
- 2** Pull outward on the (3) climate control knobs and remove. (Figure A)
- 3** Remove (2) Phillips screws from behind the outer two climate knobs. (Figure B)
- 4** Unsnap and remove the trim pieces on each side of the climate control/ashtray/pocket assembly. (Figure C)
- 5** Remove (2) Phillips screws from the bottom of the climate control/radio trim panel and unsnap and remove the entire panel. (Figure D)
- 6** Remove (4) 10 MM bolts securing the radio. Unplug and remove the radio. (Figure E)

*Continue to final assembly.*

**A**

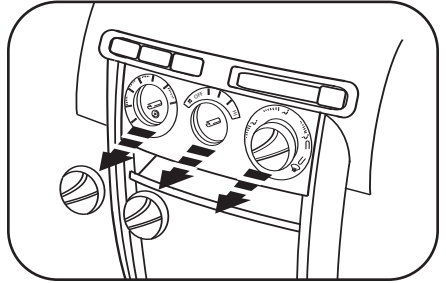

**B**

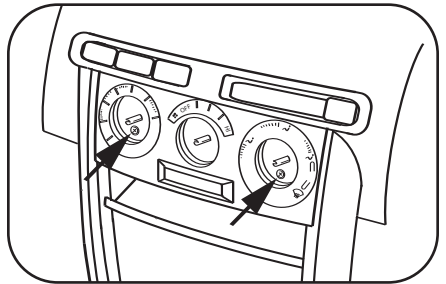

**C**

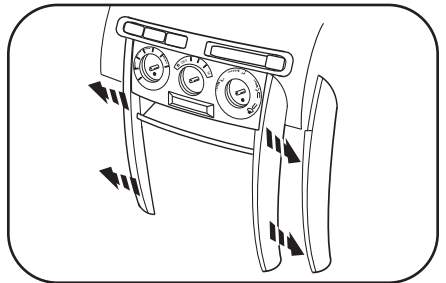

**D**

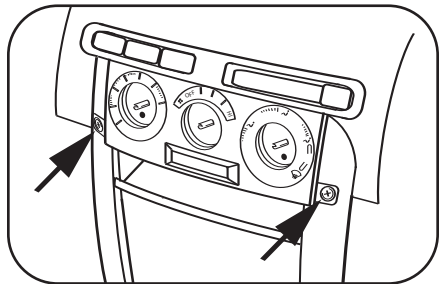

**E**

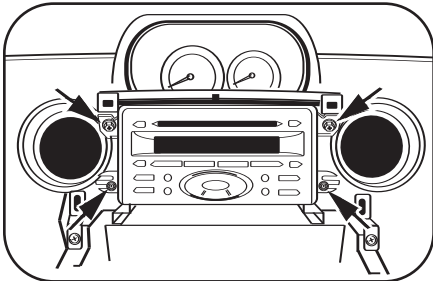

## Scion xB 2004-2009

- 1** Disconnect the negative battery terminal to prevent an accidental short circuit.
- 2** Pull outward on the (3) climate control knobs and remove. **(Figure A)**
- 3** Remove (2) Phillips screws from behind the outer (2) knobs. **(Figure B)**
- 4** Unsnap and remove the entire panel surrounding the climate controls and the radio. **(Figure C)**
- 5** Remove (4) 10 MM bolts securing the radio. Unplug and remove the radio.

*Continue to final assembly.*

**A**

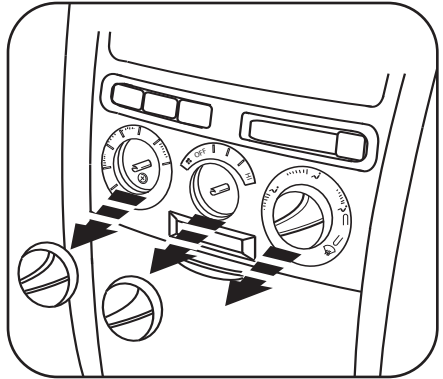

**B**

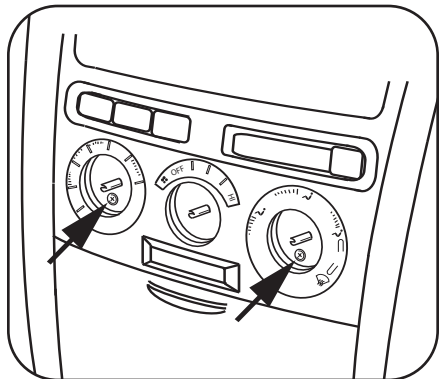

**C**

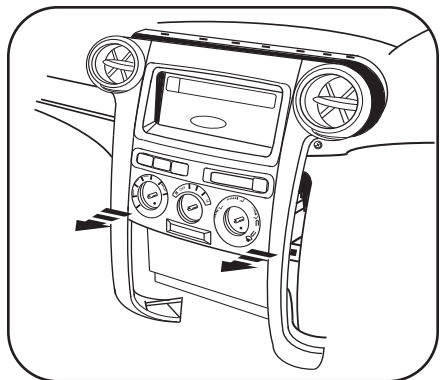

## Scion xB 2008-2009

- 1** Disconnect the negative battery terminal to prevent an accidental short circuit.
- 2** Unclip and remove the trim panel around the radio including the a/c vents. (Figure A)
- 3** Unclip and remove the trim panel at the bottom edge of the dash cavity. (Figure A)
- 4** Remove (4) 10 MM bolts securing the radio. Unplug and remove the radio. (Figure B)

*Continue to final assembly.*

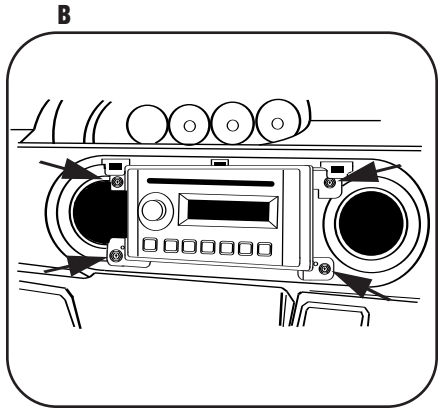
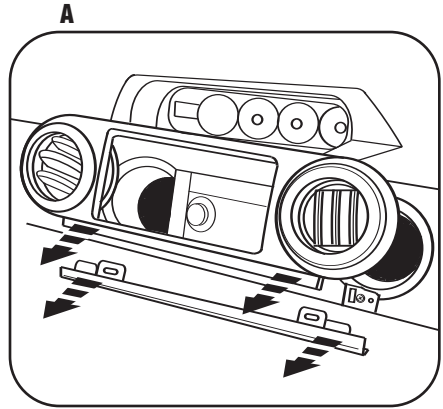

## Scion tC 2005-2009

- 1** Disconnect the negative battery terminal to prevent an accidental short circuit.
- 2** Unsnap trim from around shifter. (Not necessary to be removed). (Figure A)
- 3** Unsnap and remove panel from around radio. (Including climate controls and radio door). (Figure B)
- 4** Remove (2)10MM nuts from the top mounting locations and two Phillips screws from the bottom mounting locations to remove the radio. (Figure C)

*Continue to final assembly.*

**A**

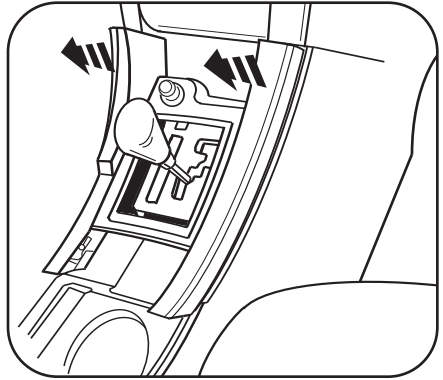

**B**

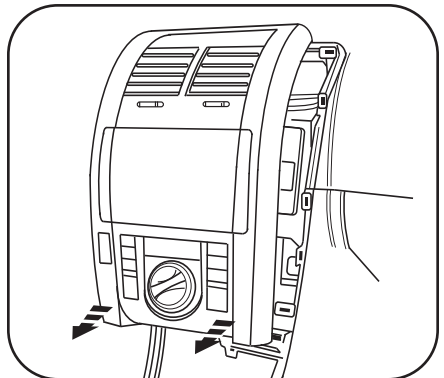

**C**

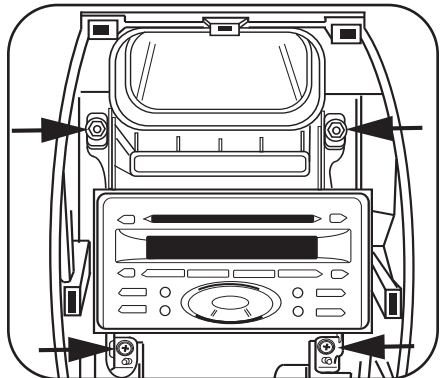

## Scion xD 2008-2009

**1** Disconnect the negative battery terminal to prevent an accidental short circuit.

**2** Unclip radio trim panel. Unplug and remove panel. (Figure A)

**3** Remove (4) Phillips screws securing the radio. Unplug and remove radio. (Figure B)

**4** Remove factory brackets from radio. Retain brackets for use during kit assembly. (Figure C)

*Continue to final assembly.*

**A**

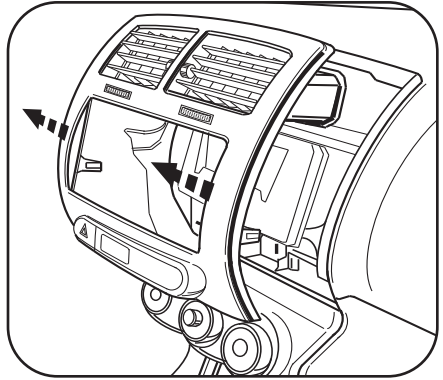

**B**

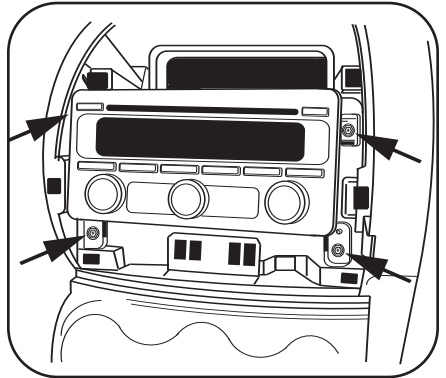

**C**

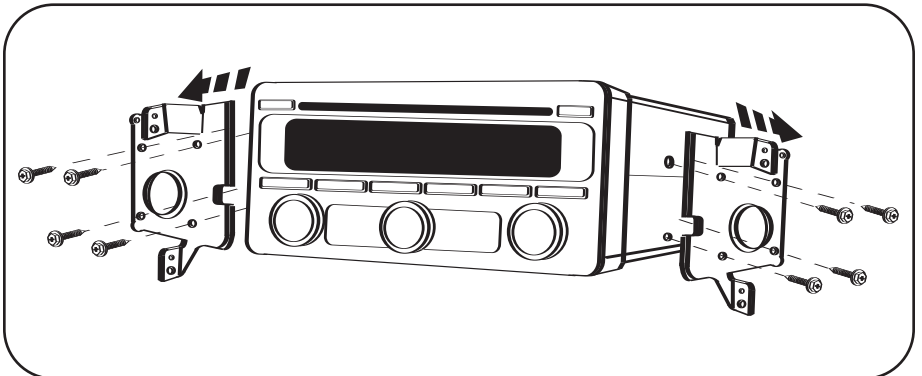

## DIN RADIO PROVISION WITH POCKET

*\*Note: Refer also to the instructions included with the aftermarket radio.*

**1** Slide the Mounting Brackets onto the sides of the Radio Housing until the side clips engage. **Note:** Use bracket set 1 for xA, xB, and tC. Use bracket set 2 for the 2008 xB and xD. (Figure A)

**2** For bracket set 1 cut and remove all mounting tabs except the tabs being used for your application. **Note:** Tabs are marked xA, xB and tC. For bracket set 2 skip to step 3. (Figure B)

**3** Slide the DIN cage into the Radio Housing and secure by bending the metal locking tabs outward. (Figure C)

**4** Slide the aftermarket radio into the cage until it snaps into place. (Figure D)

*Continue to final assembly.*

A

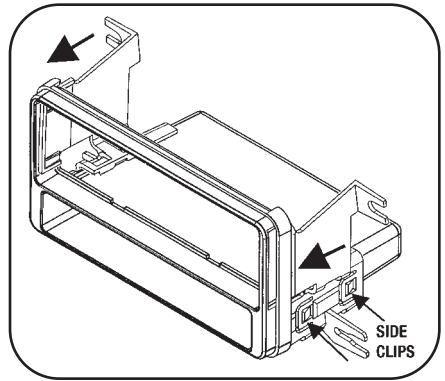

B

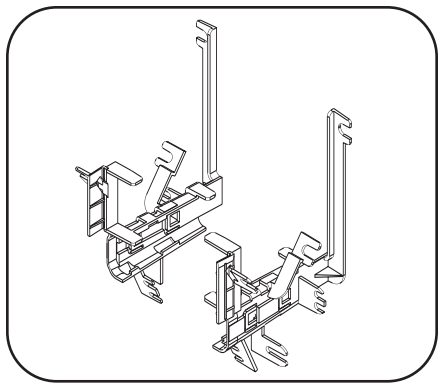

C

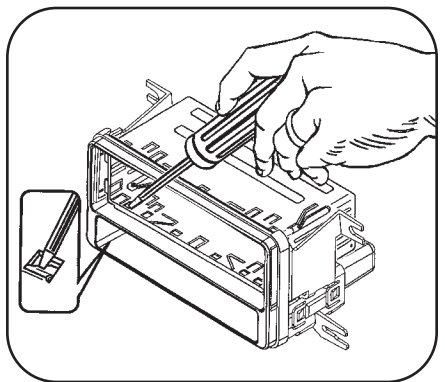

D

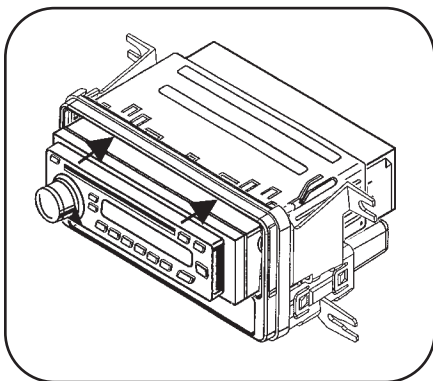



## ISO MOUNT RADIO PROVISION WITH POCKET

*\*Note: Refer also to the instructions included with the aftermarket radio.*

**1** Slide the corresponding mounting brackets onto the sides of the Radio Housing until the side clips engage.  
**Note:** Use bracket set 1 for xA, xB, and tC. Use bracket set 2 for the 2008 xB and xD. (Figure A)

**2** For bracket set 1 cut and remove all mounting tabs except the tabs being used for your application. **Note:** Tabs are marked xA, xB and tC. For bracket set 2 skip to step 3. (Figure B)

**3** Mount the ISO Brackets to the radio using the screws supplied with the radio. (Figure C)

**4** Slide the radio into the radio housing until it snaps into place. (Figure D)

**5** Snap the Trim Plate onto the front of the Radio Housing. (Figure D)

*Continue to final assembly.*

**A**

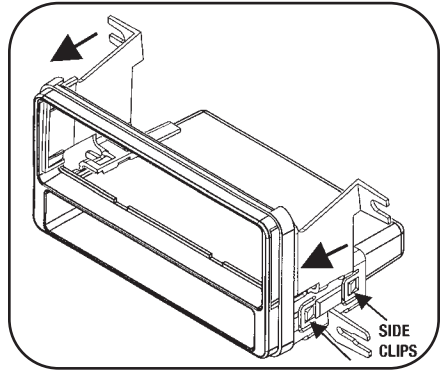

**B**

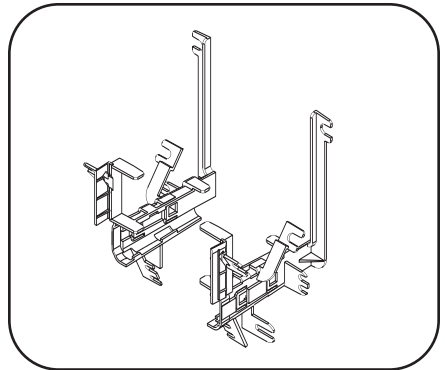

**C**

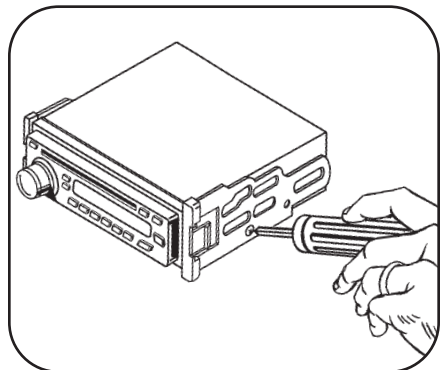

**D**

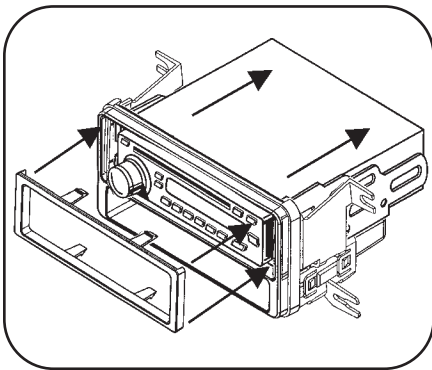

## FINAL ASSEMBLY

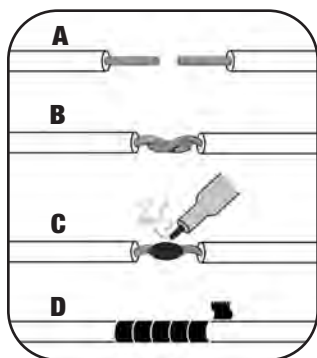

- (A) Strip wire ends back 1/2"**
- B) Twist ends together**
- C) Solder**
- D) Tape**

- 1** Locate the factory wiring harness in the dash. Metra recommends using the proper mating adapter and making connections as shown. (Isolate and individually tape off the ends of any unused wires to prevent electrical short circuit.)
- 2** Re-connect the negative battery terminal and test the unit for proper operation.
- 3** Reassemble radio and dash assemblies in reverse order of disassembly.

### FINAL WIRING CONNECTIONS

Make wiring connections using the EIA color code chart shown below and the instructions included with the head unit. Metra recommends making connections as shown below; Strip, Splice, Solder, Tape. Isolate and individually tape off ends of any unused wires to prevent electrical short circuit.

#### METRA / EIA WIRING CODE

12V Ignition / Acc. . . . .	Red	Right Front (+) . . . . .	Gray
12V Batt / Memory. . . . .	Yellow	Right Front (-). . . . .	Gray/ Black
Ground. . . . .	Black*	Left Front (+) . . . . .	White
Power Antenna. . . . .	Blue	Left Front (-). . . . .	White / Black
Amp Turn-On . . . . .	Blue / White	Right Rear (+) . . . . .	Violet
Amp Ground. . . . .	Black / White	Right Rear (-) . . . . .	Violet / Black
Illumination . . . . .	Orange	Left Rear (+) . . . . .	Green
Dimmer . . . . .	Orange / White	Left Rear (-) . . . . .	Green / Black

**\*NOTE:** When a Black wire is not present, ground radio to vehicle chassis.  
All colors may not be present on all leads due to manufacturer's specifications.



# 99-8209 INSTRUCTIONS



1-800-221-0932



[www.metraonline.com](http://www.metraonline.com)

REV. 07/20/09 © COPYRIGHT 2004-2009 METRA ELECTRONICS CORPORATION INST99-8209