



INSTALLATION INSTRUCTIONS FOR PART 99-8222

APPLICATIONS Toyota Highlander 2008-2009 NON-NAV MODELS ONLY

99-8222/ 99-8222BR

KIT FEATURES

- DIN Radio Provision with Pocket
- ISO Mount Radio Provision with Pocket
- Double DIN Radio Provision
- Stacked ISO Mount Units Provision
- **Painted to match factory dash:**
99-8222 = Black, 99-8222BR = Brown



KIT COMPONENTS

- A) Radio Housing • B) ISO Brackets • C) ISO Trim Plate • D) Double DIN Brackets
- E) Double DIN/Stacked ISO Trim Plate • F) Snap in Pocket • G) Radio Housing Brackets

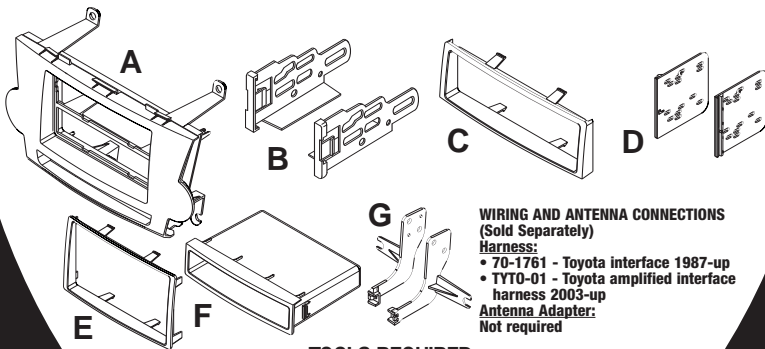

TOOLS REQUIRED:

- Small Flat Blade Screwdriver/ Panel Removal Tool
- Phillips Screwdriver • Socket Set



1-800-221-0932



www.metraonline.com

© COPYRIGHT 2007-2009 METRA ELECTRONICS CORPORATION

TABLE OF CONTENTS

Dash Disassembly

- Toyota Highlander 2008 -2009..... 1,2

Kit Preparation3

Kit Assembly

- DIN Radio Provision with Pocket4

- ISO Mount Radio Provision with Pocket..... 5

- Double DIN Radio Provision 6

- Stacked ISO Mount Units Provision 6

Final Assembly7

***Note:**

Refer also to the instructions included with the aftermarket radio.



KNOWLEDGE IS POWER

Enhance your installation and fabrication skills by enrolling in the most recognized and respected mobile electronics school in our industry. Log onto www.installerinstitute.com or call 800-354-6782 for more information and take steps toward a better tomorrow.

TOYOTA HIGHLANDER 2008-2009

- 1 Disconnect the negative battery terminal to prevent an accidental short circuit.
- 2 Unclip and remove the a/c vent panel. (Figure A)
- 3 Unclip the trim panel containing the climate controls and pocket. Unplug the climate controls and remove the trim panel. (Figure B)
- 4 Remove (4) 10 MM bolts securing the radio assembly. Unplug and remove the radio assembly. (Figure C)

Continued on page 2

A

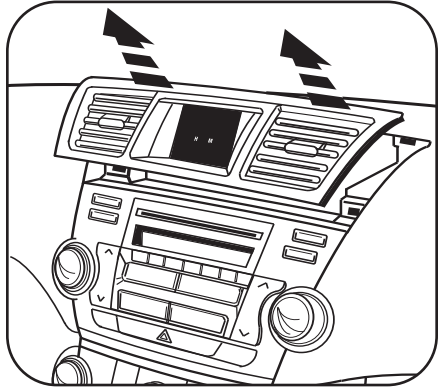

B

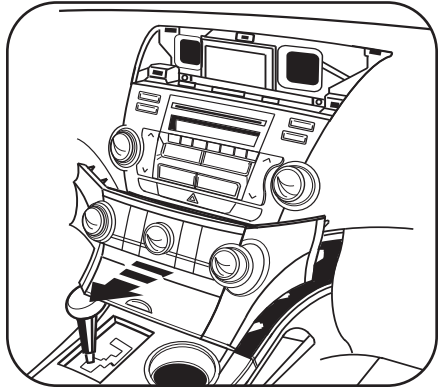

C

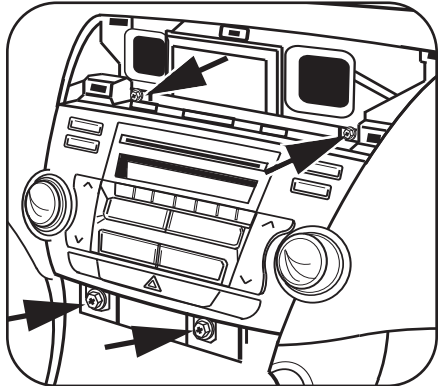

TOYOTA HIGHLANDER 2008-2009

- 5** Remove the (2) Phillips screws securing the clock/display then remove the clock/display from the radio assembly. (Retain the screws and clock/display for re-use during kit preparation.) (Figure D)

- 6** Unclip and remove the hazard switch assembly from radio assembly. (Retain the hazard switch assembly for re-use during kit preparation.) (Figure E)

- 7** Remove (4) spring clips from the back of the radio. (Retain the spring clips for re-use during kit preparation.) (Figure F)

Continue to kit preparation

D

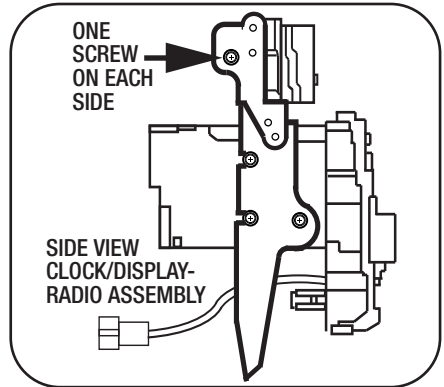

E

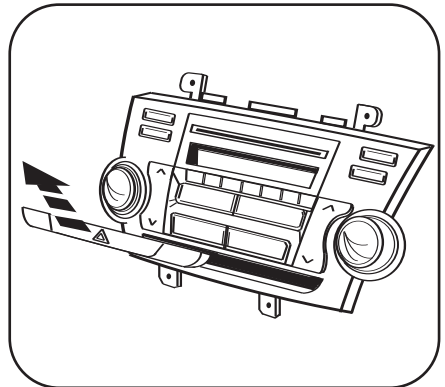

F

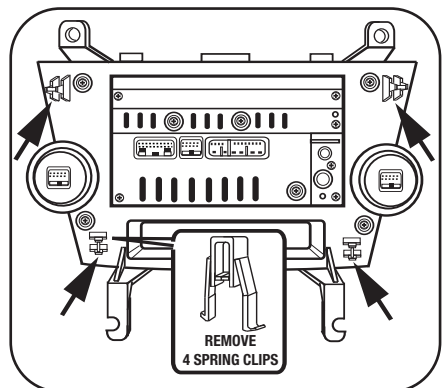

TOYOTA HIGHLANDER 2008-2009

- 1 Attach the radio housing brackets to the radio housing. **Note:** Make sure that the leg on the bracket is on the outside of the leg on the radio housing. (Figure A)
- 2 Attach the clock/display to the brackets/radio housing assembly using the factory hardware. (Figure B)
- 3 Snap the hazard switch assembly into the radio housing. (Figure C)
- 4 Attach the (4) spring clips to the back of the radio housing. (Figure D)

Continue to kit assembly

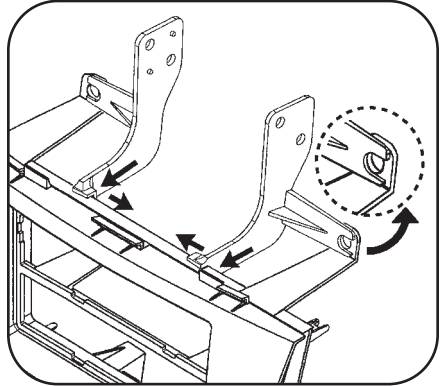
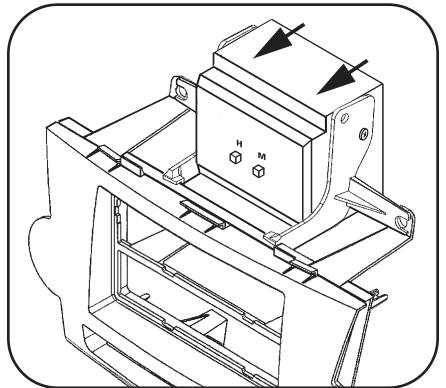
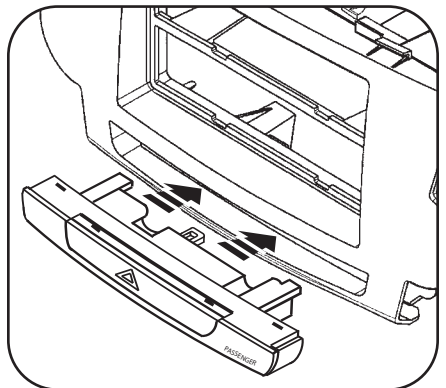
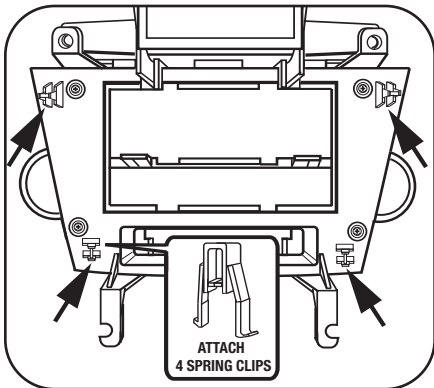
A

B

C

D

DIN RADIO PROVISION WITH POCKET

**Note: Refer also to the instructions included with the aftermarket radio.*

- 1 Slide the DIN cage into the Radio Housing and secure by bending the metal locking tabs outward. (Figure A)
- 2 Slide the aftermarket radio into the DIN cage until it snaps into place. (Figure B)
- 3 Snap the pocket into the radio housing. (Figure C)

Continue to final assembly.

A

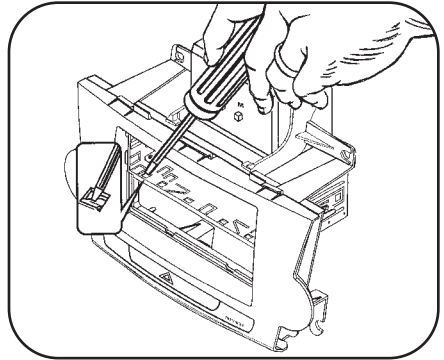

B

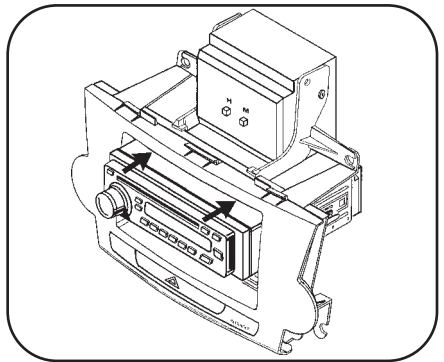

C

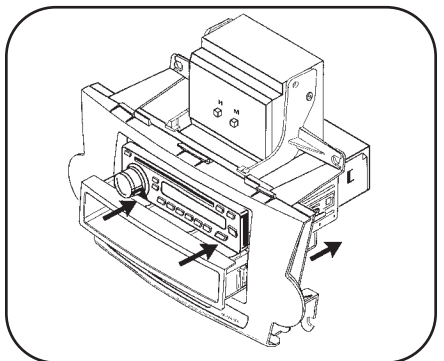

ISO MOUNT RADIO PROVISION WITH POCKET

**Note: Refer also to the instructions included with the aftermarket radio.*

- 1 Mount the ISO Brackets to the radio using the screws supplied with the radio. (Figure A)
- 2 Slide the radio into the radio housing until it snaps into place. (Figure B)
- 3 Snap the ISO Trim Plate onto the front of the Radio Housing. (Figure B)
- 4 Snap the Pocket into the Radio Housing. (Figure C)

Continue to final assembly.

A

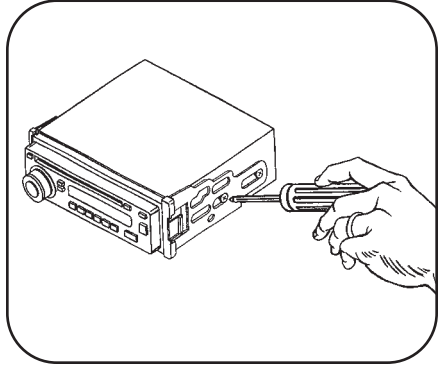

B

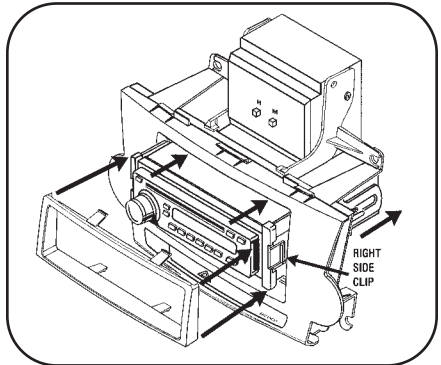

C

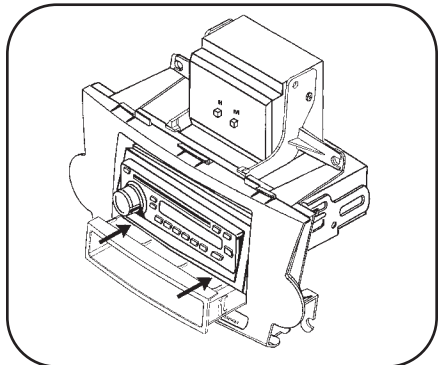

DOUBLE DIN OR STACKED ISO MOUNT UNITS PROVISION

**Note: Refer also to the instructions included with the aftermarket radio.*

- 1** Cut and remove the center bar from the Radio Housing. (Figure A)
- 2** Snap the Double DIN brackets to the inside edge of the Radio Housing. (Figure B)
- 3** Slide the Double DIN or stacked ISO mount units into the bracket/radio housing assembly then secure it to the assembly using the screws supplied with the units. (Figure C)
- 4** Snap the Double DIN/Stacked ISO Trim Plate onto the front of the Radio Housing. (Figure C)

Continue to final assembly.

A

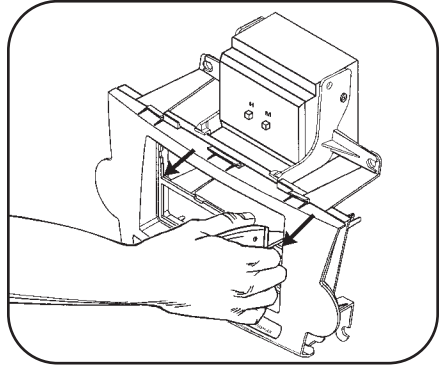

B

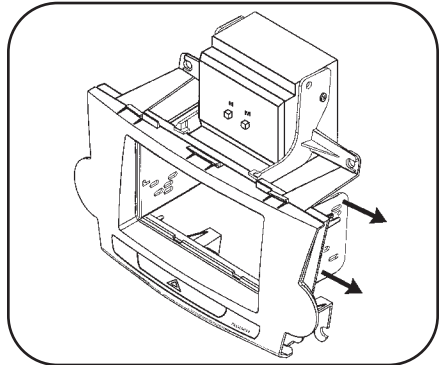

C

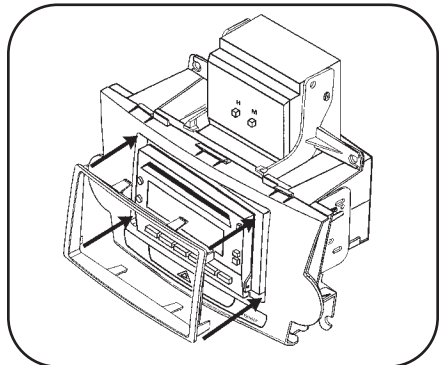

FINAL ASSEMBLY

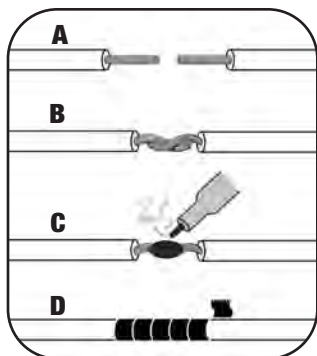

- (A) Strip wire ends back 1/2"**
- B) Twist ends together**
- C) Solder**
- D) Tape**

- 1** Locate the factory wiring harness in the dash. Metra recommends using the proper mating adapter and making connections as shown. (Isolate and individually tape off the ends of any unused wires to prevent electrical short circuit.)
- 2** Re-connect the negative battery terminal and test the unit for proper operation.
- 3** Reassemble radio and dash assemblies in reverse order of disassembly.

FINAL WIRING CONNECTIONS

Make wiring connections using the EIA color code chart shown below and the instructions included with the head unit. Metra recommends making connections as shown below; Strip, Splice, Solder, Tape. Isolate and individually tape off ends of any unused wires to prevent electrical short circuit.

METRA / EIA WIRING CODE

12V Ignition / Acc. Red	Right Front (+) Gray
12V Batt / Memory. Yellow	Right Front (-). Gray/ Black
Ground. Black*	Left Front (+) White
Power Antenna. Blue	Left Front (-). White / Black
Amp Turn-On Blue / White	Right Rear (+) Violet
Amp Ground. Black / White	Right Rear (-). Violet / Black
Illumination Orange	Left Rear (+) Green
Dimmer Orange / White	Left Rear (-). Green / Black

***NOTE:** When a Black wire is not present, ground radio to vehicle chassis.
All colors may not be present on all leads due to manufacturer's specifications.

99-8222 INSTRUCTIONS



1-800-221-0932



www.metraonline.com

REV. 07/20/09 © COPYRIGHT 2007-2009 METRA ELECTRONICS CORPORATION INST99-8222