

Faceplate #1

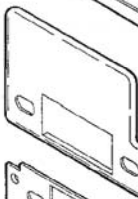

Faceplate #2

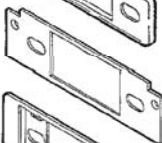

Faceplate #3

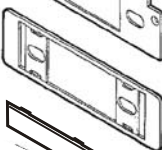

Faceplate #4

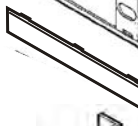

Equalizer Dummy Plate



Mounting Brackets (Justy)

(2) Hex-head Screws



(4) Speed Clips

(4) Oval-head Screws



TOOLS REQUIRED



Phillips screwdriver



Cutting tool



Socket wrench

99-8900 AW-934SB DW-8900 INSTALLATION INSTRUCTIONS

APPLICATIONS

<u>CAR</u>	<u>PAGE</u>
SUBARU	
Brat 1982-87.....	1
DL 1981-84.....	1
DL (sedan) 1985-89.....	2
DL (hatchback) 1986-89.....	2
GL 1981-84.....	1
GL (sedan) 1985-89.....	2
GL (hatchback) 1986-89.....	2
Justy 1987-94.....	3
Legacy 1990-94.....	4
Loyale 1990-94.....	2
RX (sedan) 1985-89.....	2

SUBARU Brat 1982-87 / DL 1981-84 GL 1981-84

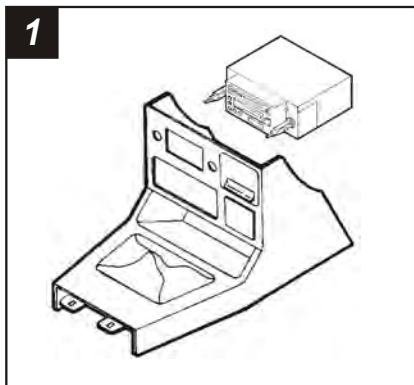

Disconnect the negative battery terminal to prevent an accidental short circuit. Remove (4) screws securing the dash console, lift the console out and disconnect the wiring.

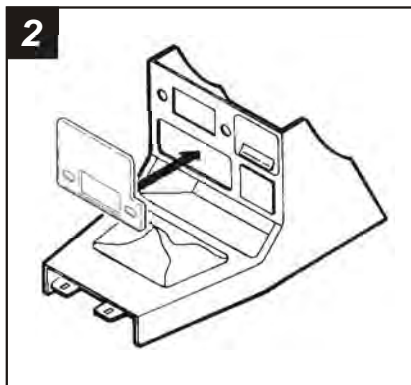

Locate the **Mounting Brackets**, **Shaft Masks** and **Faceplate #2**.

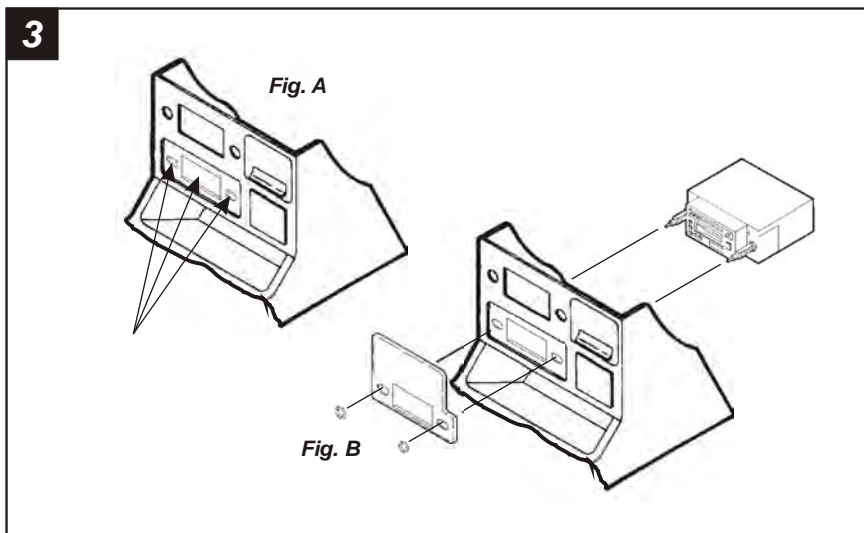

Using a dremel tool, cut the plastic along the scribed lines ("A") until the shaft holes and nose hole is formed. (see Fig. A). Slide the aftermarket head unit through the holes in the console and kit and secure with shaft nuts. (see Fig. B)

**SUBARU DL 1985-89 / GL 1985-89 / RX (sedan) 1985-89
DL (hatchback) 1986-89 / GL (hatchback) 1986-89
Loyale 1990-94**

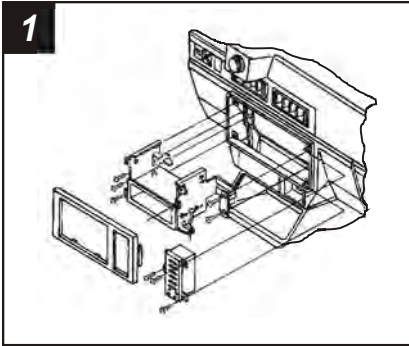

Disconnect the negative battery terminal to prevent an accidental short circuit. Unclip the radio trim bezel and remove. Remove (3) Phillips screws securing the trip computer and remove. Remove (7) Phillips screws securing the factory radio assembly and disconnect the wiring.

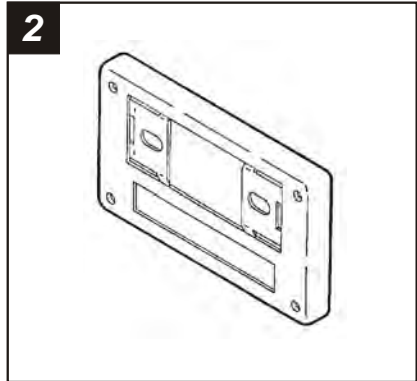

Locate **Faceplate #1**.

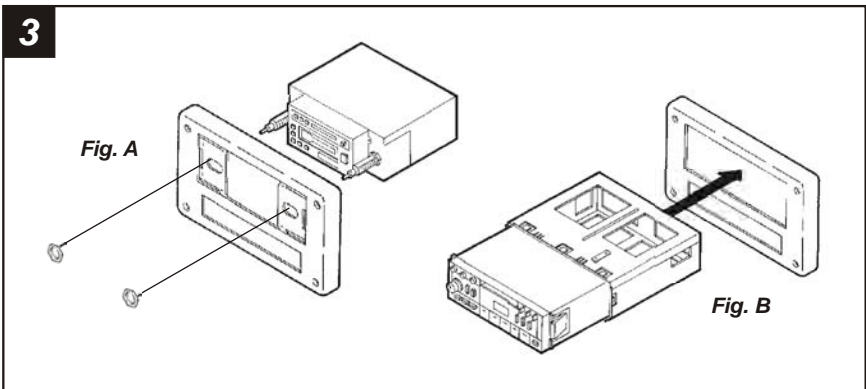

2-SHAFT HEAD UNITS: Slide the aftermarket head unit into the kit and secure with shaft nuts. (see Fig. A). Skip to the Installation Instructions for ALL VEHICLES on Page #5.

DIN HEAD UNITS: Cut and remove the shaft supports from **Faceplate #1**. Slide the DIN cage into the kit and secure by bending the metal locking tabs down. Slide the aftermarket head unit into the cage until secure. (see Fig. B). Skip to the Installation Instructions for ALL VEHICLES on Page #5.

(If an equalizer will be included, slide the unit into the back of the **Radio Housing** and secure. If an equalizer will NOT be included, snap the **Equalizer Dummy Plate** into the opening).

SUBARU Justy 1987-94

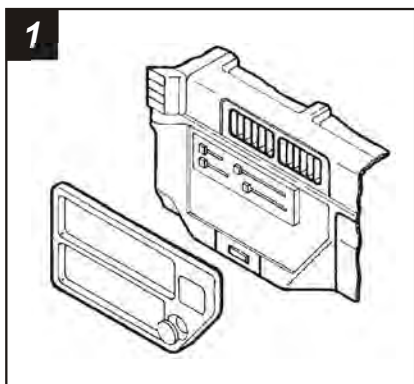

Disconnect the negative battery terminal to prevent an accidental short circuit. Remove the ashtray and (3) screws exposed on the retaining bracket. Remove the climate control knobs. Using a small screwdriver, pry out on the climate control control cover and remove (2) screws exposed. Remove (2) screws above the ashtray bracket. Unclip the radio trim bezel. Disconnect the clock and cigarette lighter wiring and remove the bezel. Remove the screws securing the factory head unit and disconnect the wiring.

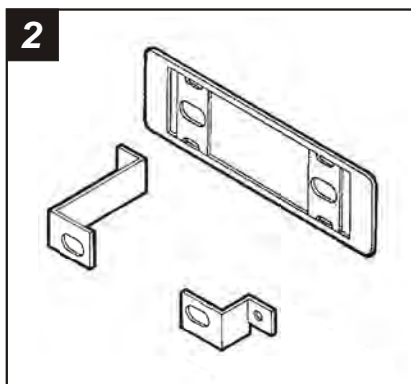

Locate the **Mounting Brackets** and **Faceplate #4**.

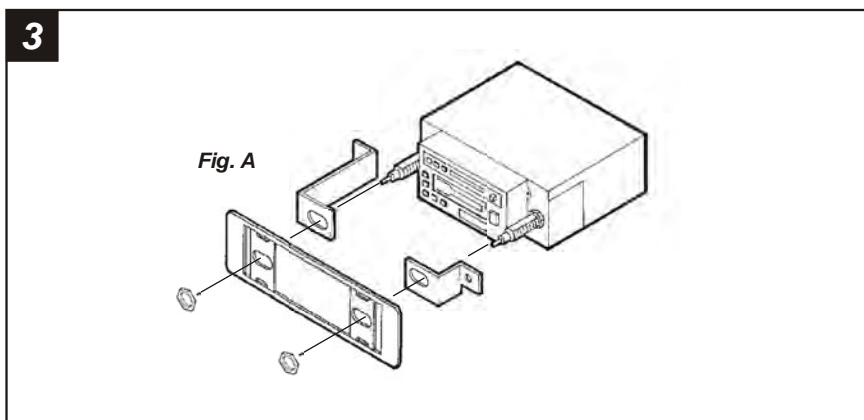

2-SHAFT HEAD UNITS: Slide the aftermarket head unit through the Faceplate and **Mounting Brackets** and secure with shaft nuts. (see Fig. A). Skip to the *Installation Instructions for ALL VEHICLES on Page #5*.

DIN HEAD UNITS: Cut and remove the shaft supports from **Faceplate #4**. Skip to the *Installation Instructions for ALL VEHICLES on Page #5*.

SUBARU Legacy 1990-94

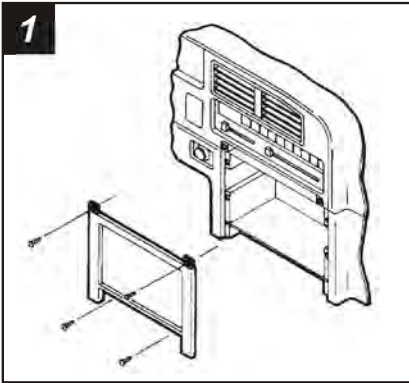

Disconnect the negative battery terminal to prevent an accidental short circuit. Remove the cupholder and (2) screws exposed. Remove the ashtray and (2) screws exposed on the ashtray bracket. Unclip the radio trim bezel and remove. Remove the screws securing the factory head unit and disconnect the wiring.

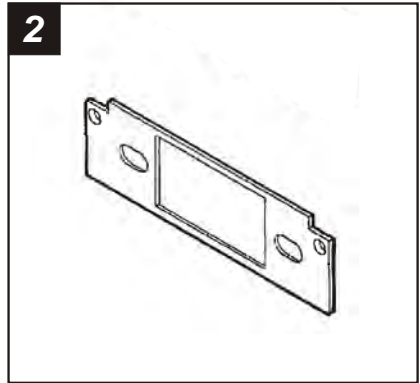

Locate **Faceplate #3**.

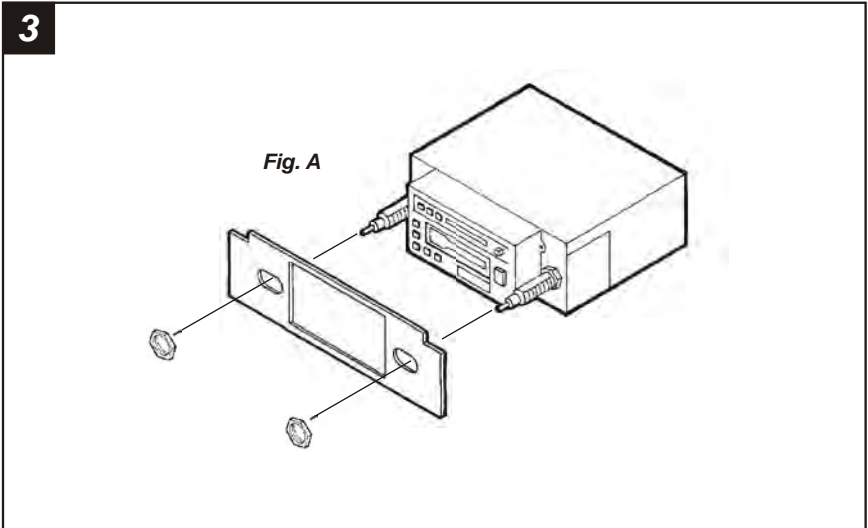

2-SHAFT HEAD UNITS: Slide the aftermarket head unit into the kit and secure with shaft nuts. (see Fig. A). Skip to the Installation Instructions for ALL VEHICLES on Page #5.

ALL VEHICLES

5

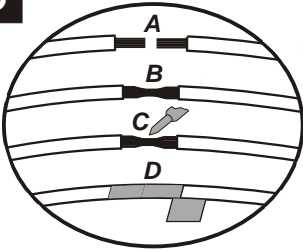

- A) Strip wire ends back $\frac{1}{2}$ "
- B) Twist ends together
- C) Solder
- D) Tape

Locate the factory wiring harness in the dash. Metra recommends using the proper mating adaptor and making connections as shown. (Isolate and individually tape off the ends of any unused wires to prevent electrical short circuit).

6

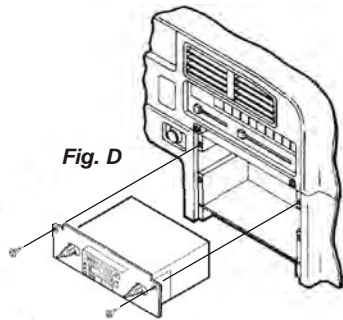
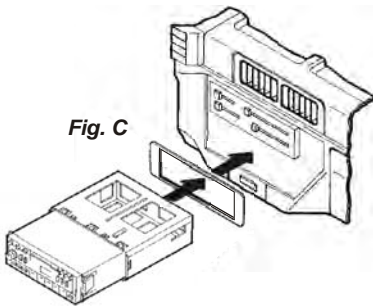
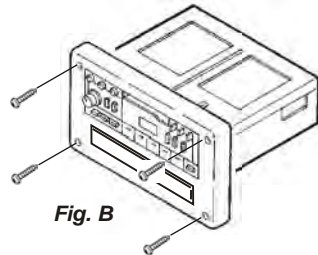
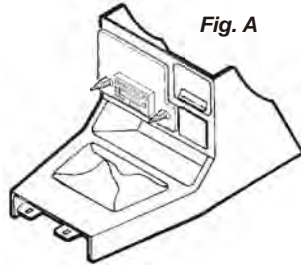

DL 1981-84, GL 1981-84, BRAT: Re-connect the battery terminal and test the unit for proper operation. Mount the console assembly to the dash with (4) screws previously removed in step #1. (see Fig. A)

DL 1985-89, GL 1985-89, LOYALE, RX: Re-connect the battery terminal and test the unit for proper operation. Mount the head unit/kit assembly to the sub-dash with (4) **Oval-head Screws** and (4) **Speed Clips** supplied. (see Fig. B)

JUSTY: Re-connect the battery terminal and test the unit for proper operation. For 2-shaft head units, mount the head unit/kit assembly to the sub-dash with (2) Phillips screws previously removed in step #1. For DIN head units, slide the DIN cage through the Faceplate and into the sub-dash and secure by bending the metal locking tabs down. Slide the aftermarket head unit into the cage until secure. (see Fig. C)

LEGACY: Re-connect the battery terminal and test the unit for proper operation. Mount the head unit/kit assembly to the sub-dash with (2) **Hex-head Screws** supplied. (see Fig. D)

