



INSTALLATION INSTRUCTIONS FOR PART 99-9009

APPLICATIONS

VW Touareg/Touareg2 2004-2009

99-9009



KIT FEATURES

- DIN Head Unit Provision with Pocket
- ISO DIN Head Unit Provision with Pocket

KIT COMPONENTS

A) Radio Housing • B) ISO Snap-In Brackets • C) Trim Plate

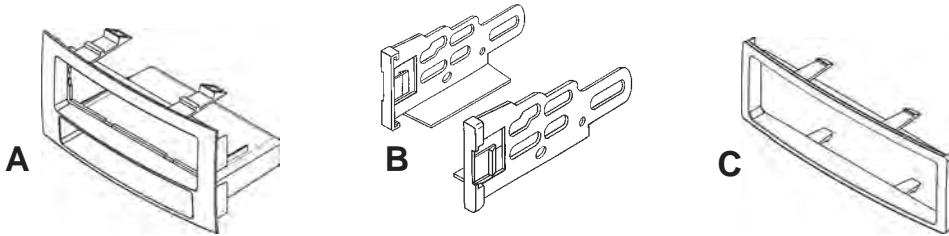

TOOLS REQUIRED:

86-9001 Radio Removal Tools (2 sets) • Flat Blade Screwdriver

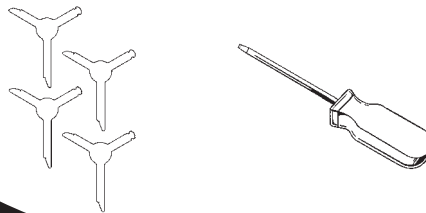

1-800-221-0932



www.metraonline.com

© COPYRIGHT 2004-2009 METRA ELECTRONICS CORPORATION



99-9009

TABLE OF CONTENTS

Dash Disassembly	1
Kit Assembly	2-3
Final Assembly	4
Notes	5



KNOWLEDGE IS POWER

Enhance your installation and fabrication skills by enrolling in the most recognized and respected mobile electronics school in our industry. Log onto www.installerinstitute.com or call 800-354-6782 for more information and take steps toward a better tomorrow.

2004-2009 VW TOUAREG

- 1** Disconnect the negative battery terminal to prevent an accidental short circuit.
- 2** Insert the long ends of the 86-9001 into the slots on the factory radio and pull out to remove. (Figure A)

NOTE:

Flat edge of key should point outward.

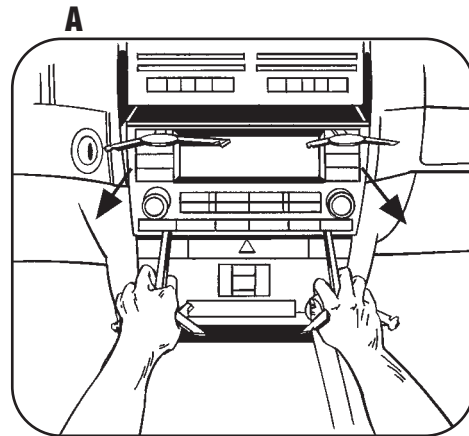

DASH DISASSEMBLY

DIN HEAD UNIT PROVISIONS

- 1 Slide the DIN cage into the Radio Housing and secure by bending the metal locking tabs down. (Figure A)
- 2 Slide the aftermarket head unit into the cage and secure. (Figure B)

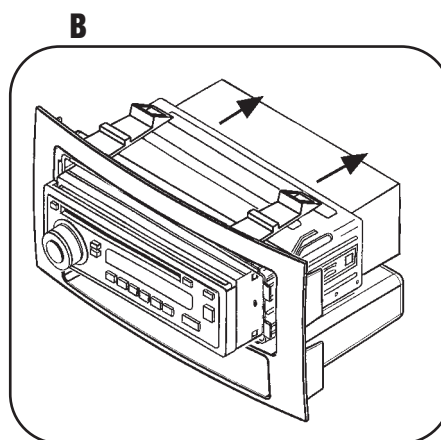
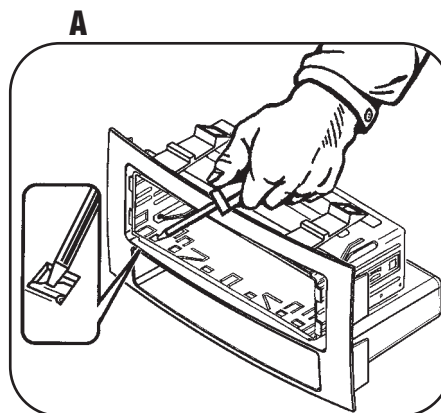

ISO DIN HEAD UNIT PROVISIONS

- 1** Mount the ISO Brackets to the head unit with the screws supplied with the unit. (Figure A)
- 2** Slide the head unit into the radio opening until the side clips engage. (Figure B)
- 3** Snap the Trim plate into the Radio Housing. (Figure B)

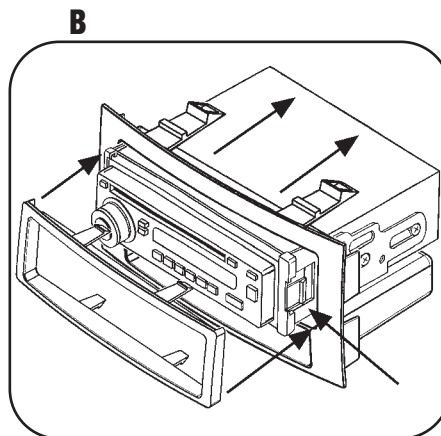
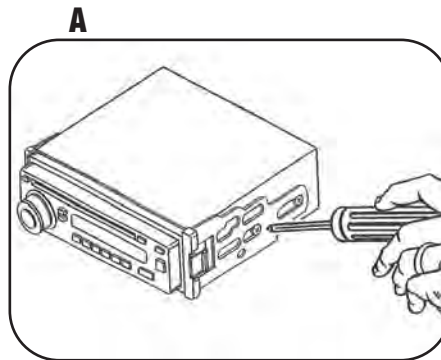

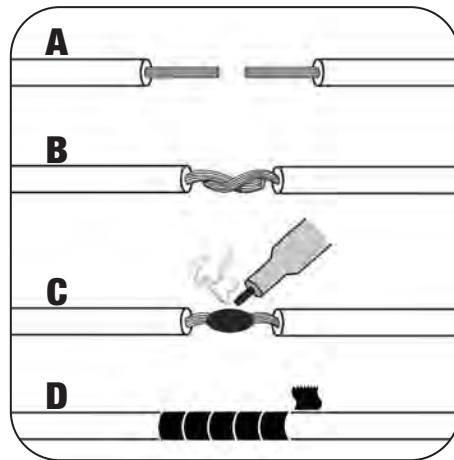
FINAL ASSEMBLY

- A) Strip wire ends back 1/2"**
- B) Twist ends together**
- C) Solder**
- D) Tape**

- 1** Locate the factory wiring harness in the dash. Metra recommends using the proper mating adapter and making the connections as shown. (Isolate and individually tape off the ends of any unused wires to prevent electrical short circuit)

- 2** Re-connect the negative battery terminal and test the unit for proper operation.

- 3** Reassemble radio and dash assemblies in reverse order of disassembly.



99-9009

NOTES

INST99-9009



1-800-221-0932



www.metraonline.com

Rev. 04-16-09

© COPYRIGHT 2004-2009 METRA ELECTRONICS CORPORATION

INST99-9009