



## INSTALLATION INSTRUCTIONS FOR PART 99-9010

### APPLICATIONS

2005-2006 VW New Jetta

# 99-9010

#### KIT FEATURES

- DIN Head Unit Provisions with Removable Pocket

#### KIT COMPONENTS

A) Radio Housing | B) Pocket

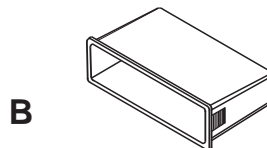
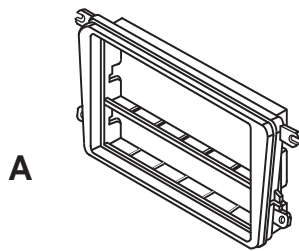

#### TOOLS REQUIRED:

Small Flat Blade Screwdriver | T-20 TORX SCREWDRIVER

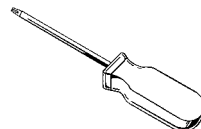
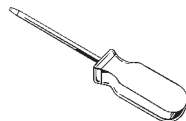

1-800-221-0932



[www.metraonline.com](http://www.metraonline.com)

© COPYRIGHT 2004 METRA ELECTRONICS CORPORATION



# 99-9010

## TABLE OF CONTENTS

<i>Dash Disassembly</i> .....	<b>1-2</b>
<i>Kit Assembly</i> .....	<b>3</b>
<i>Final Assembly</i> .....	<b>4</b>

## 2005-2006 VW NEW JETTA

- 1 Disconnect the negative battery terminal to prevent an accidental short circuit.
- 2 Unclip and remove the grille from the top-center of dash. (Figure A)
- 3 Remove one T-20 torx screw from black insert from under grille removed in step one. (Figure B)
- 4 Remove insert. (Figure C)
- 5 Remove two T-20 torx screws from under black insert removed in step two. (Figure D)

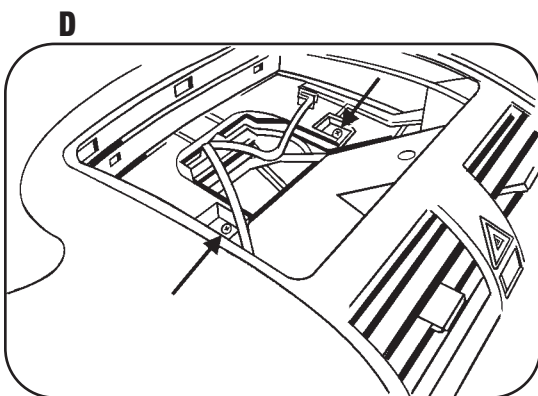
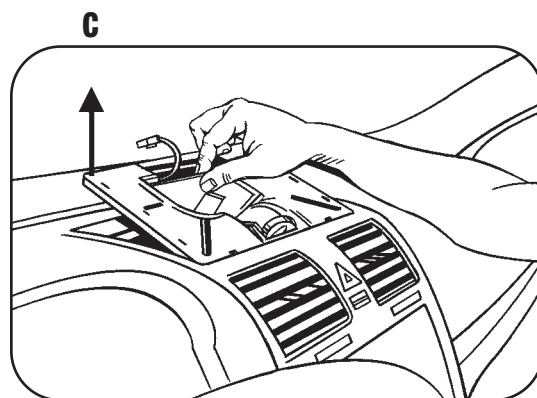
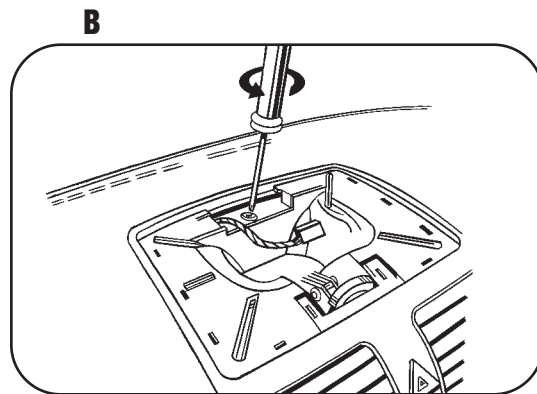
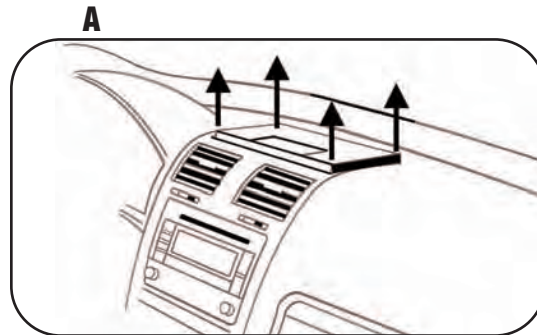

**DASH DISASSEMBLY**

### 2005-2006 VW NEW JETTA

- 6 Unsnap and remove the vent assembly above the radio. (Figure E)
- 7 Remove two T-20 torx screws from top sides of radio/climate panel. (Figure F)
- 8 Remove panel. (Figure G)
- 9 Remove four T-20 torx screws to remove the radio. (Figure H)

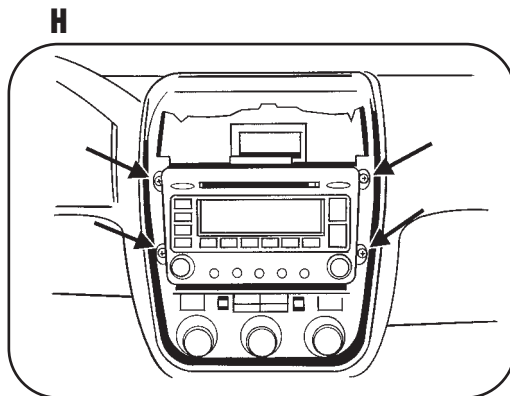
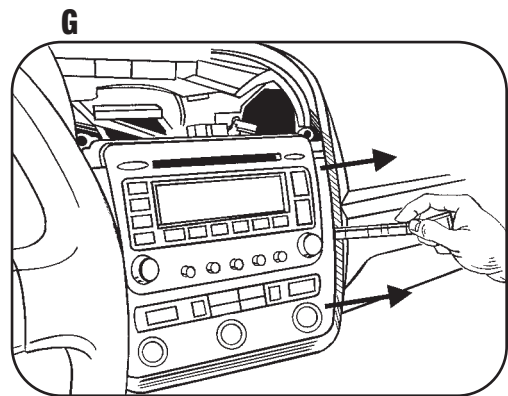
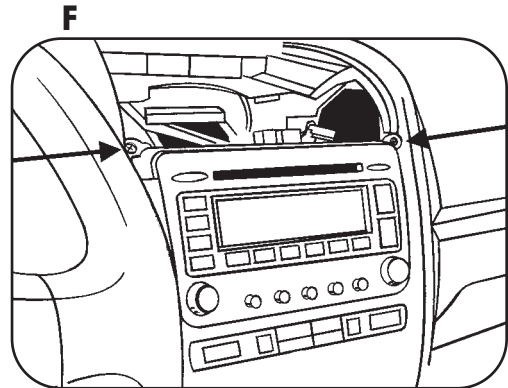
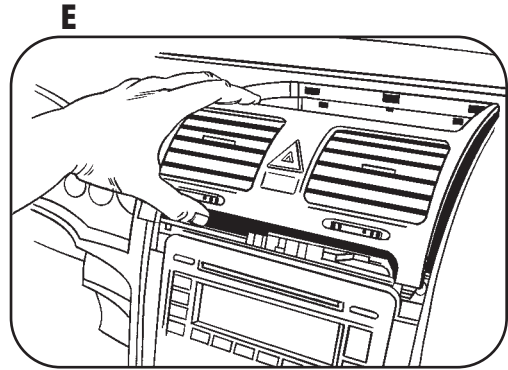

## DIN HEAD UNIT PROVISIONS

- 1 Slide the DIN cage into the Radio Housing and secure by bending the metal locking tabs down. (Figure A)
- 2 Slide the aftermarket head unit into the DIN cage until secure. (Figure B)
- 3 Slide the included pocket into the Radio Housing until secure. (Figure C)
- 4 Install kit assembly into dash.

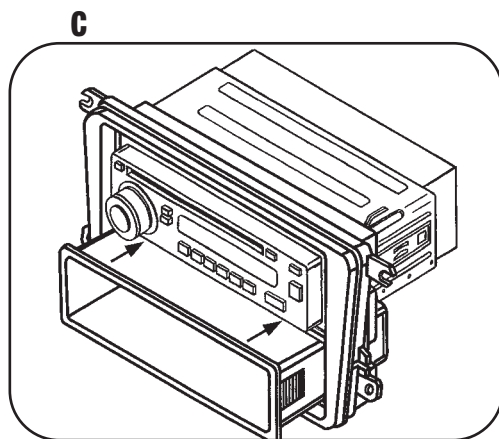
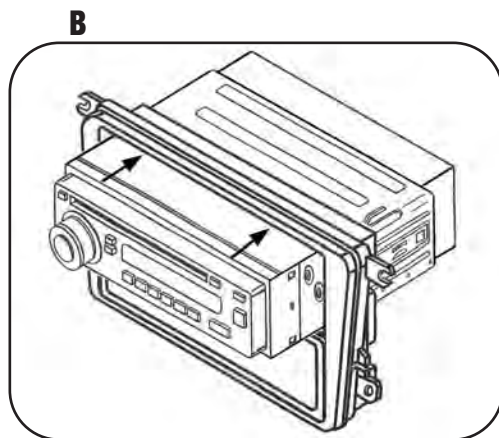
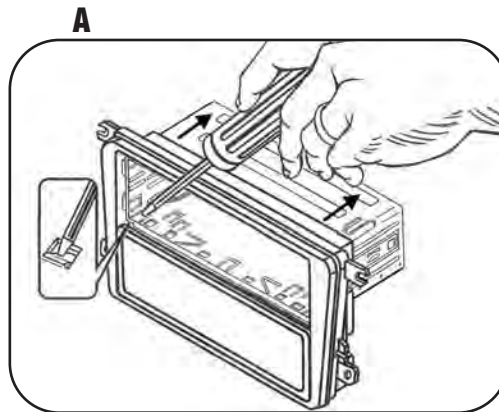

**KIT ASSEMBLY**



## 99-9010

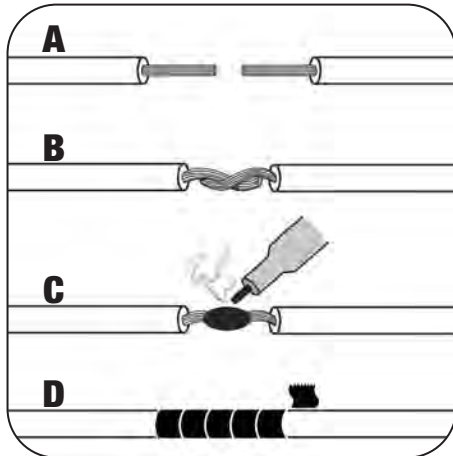

- A) Strip wire ends back 1/2"**
- B) Twist ends together**
- C) Solder**
- D) Tape**

**FINAL ASSEMBLY**

- 1** Locate the factory wiring harness in the dash. Metra recommends using the proper mating adapter and making the connections as shown. (Isolate and individually tape off the ends of any unused wires to prevent electrical short circuit)
- 2** Re-connect the negative battery terminal and test the unit for proper operation.
- 3** Reassemble radio and dash assemblies in reverse order of disassembly.



**99-9010**

A large rectangular area with a thin black border, containing numerous horizontal lines for writing notes.

**NOTES**

# 99-9010 INSTRUCTIONS



1-800-221-0932



[www.metraonline.com](http://www.metraonline.com)

REV. 01/13/06

© COPYRIGHT 2004 METRA ELECTRONICS CORPORATION

INST99-9010