



## INSTALLATION INSTRUCTIONS FOR PART 99-9107B

### APPLICATIONS

# Audi A4 / S4

# 2002-2008

## (With Symphony Radio)

# 99-9107B

### KIT FEATURES

- DIN Head Unit Provision with Pocket
- ISO DIN Head Unit Provision with Pocket
- Double DIN Head Unit Provision
- Painted Matte Black to Match Factory



### KIT COMPONENTS

- A) Radio Housing • B) Pocket • C) Trim Plate • D) ISO Brackets • E) Double DIN Trim Plate
- F) Double DIN Brackets

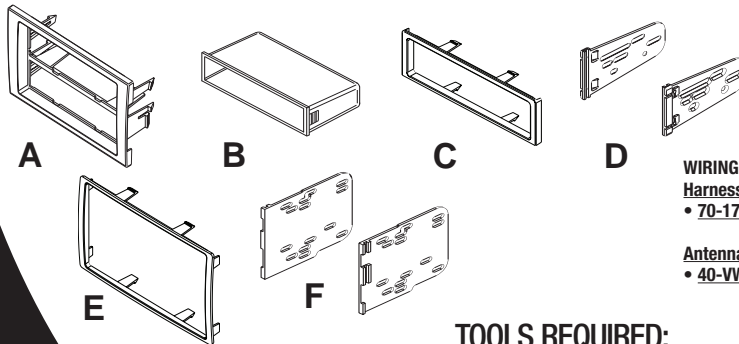

#### WIRING AND ANTENNA CONNECTIONS (Sold Separately)

##### Harness:

- **70-1787** - VW / Audi Harness 1993-up

##### Antenna Adapter:

- **40-VW10** - Euro Antenna Adapter 1986-up

### TOOLS REQUIRED:

- (2) 86-9001 Head Unit Removal Tools • Small Flat Blade Screwdriver • Phillips Screwdriver

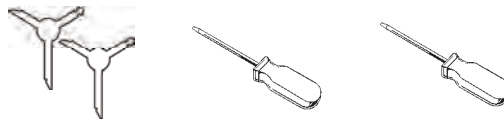

1-800-221-0932



www.metraonline.com

© COPYRIGHT 2004-09 METRA ELECTRONICS CORPORATION



# **TABLE OF CONTENTS**

## **Dash Disassembly**

**- Audi A4 / S4 2002-2008 w/Symphony Radio ..... 1**

## **Kit Assembly**

**- DIN Head Unit Provision with Pocket ..... 2**

**- ISO DIN Head Unit Provision with Pocket ..... 3**

**- Double DIN Head Unit Provision ..... 4**

**Final Assembly ..... 5**



### **KNOWLEDGE IS POWER**

Enhance your installation and fabrication skills by enrolling in the most recognized and respected mobile electronics school in our industry. Log onto [www.installerinstitute.com](http://www.installerinstitute.com) or call 800-354-6782 for more information and take steps toward a better tomorrow.



Metra recommends MECP certified technicians..



**AUDI A4 / S4 2002-2008 W/SYMPHONY RADIO**

- 1 Disconnect the negative battery terminal to prevent an accidental short circuit.
- 2 Insert Metra's 86-9001 into the slots in the factory head unit and pull the unit out. (Figure A)
- 3 Disconnect the wiring.

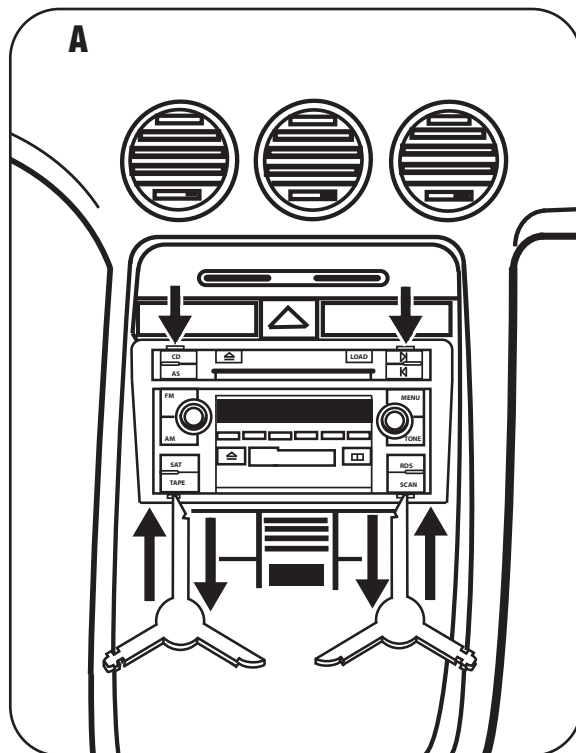

## DIN HEAD UNIT PROVISION WITH POCKET

- 1** Snap the DIN cage into the Radio Housing and secure by bending the metal locking tabs down. (Figure A)
- 2** Locate the factory wiring harness in the dash. Metra recommends using the proper mating adapter from Metra or AXCESS. Re-connect the negative battery terminal and test the unit for proper operation.
- 3** Snap radio assembly into factory radio opening.
- 4** Slide the aftermarket radio into the cage and secure. (Figure B)
- 5** Snap the pocket into the Radio Housing until secure. (Figure C)

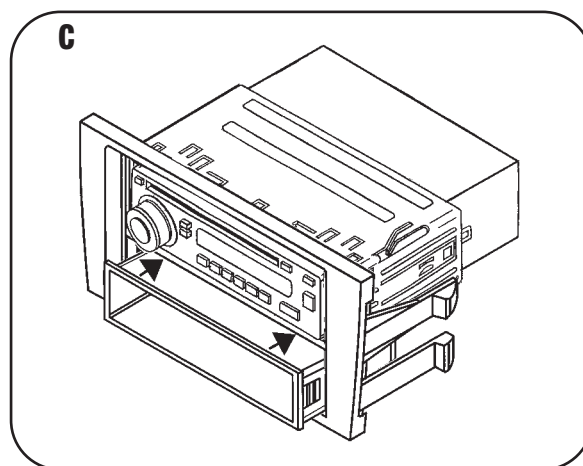
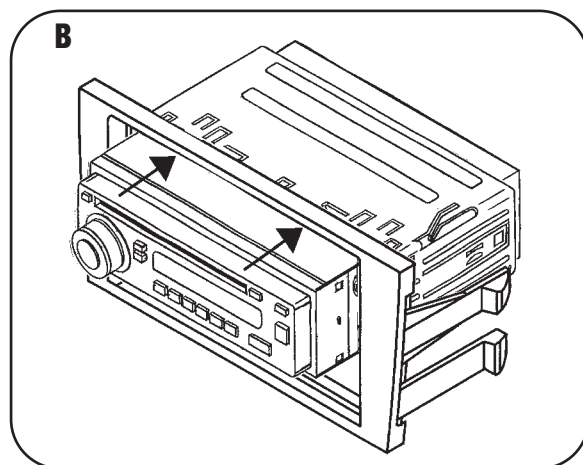
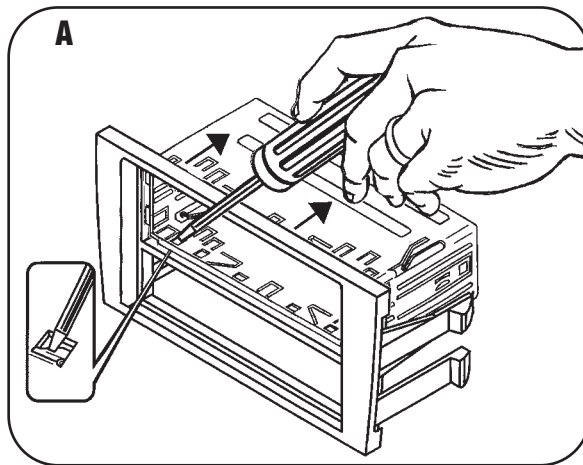



## ISO DIN HEAD UNIT PROVISION

- 1** Mount the ISO Brackets to the head unit with the screws supplied with the unit. (Figure A)
- 2** Slide the head unit into the radio opening until the slide clips engage. (Figure B)
- 3** Snap the ISO Trim Plate into the Radio Housing. (Figure B)
- 4** Snap the pocket into the Radio Housing. (Figure C)
- 5** Locate the factory wiring harness in the dash. Metra recommends using the proper mating adapter from Metra or AXXESS. Re-connect the negative battery terminal and test the unit for proper operation.
- 6** Snap the radio assembly into the factory radio opening.

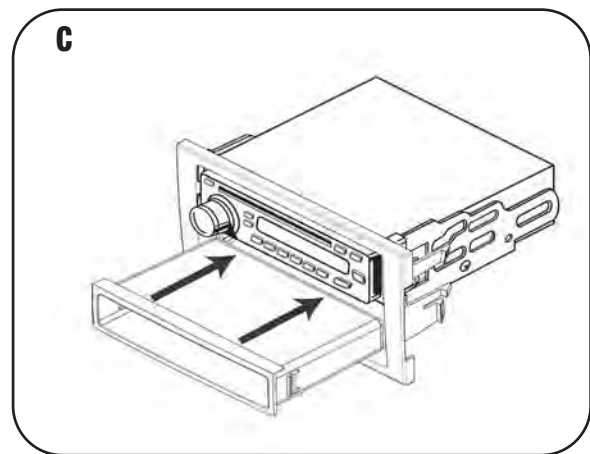
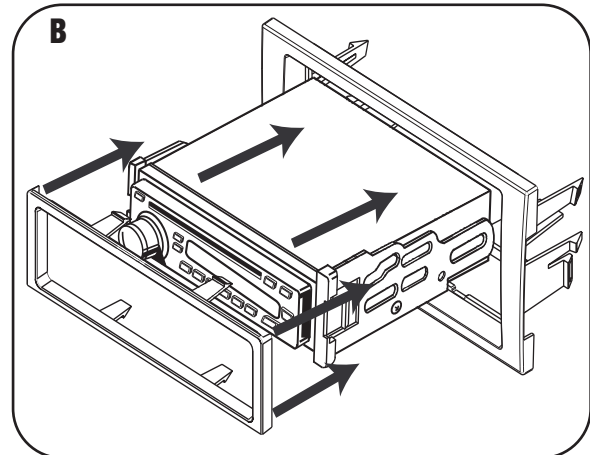
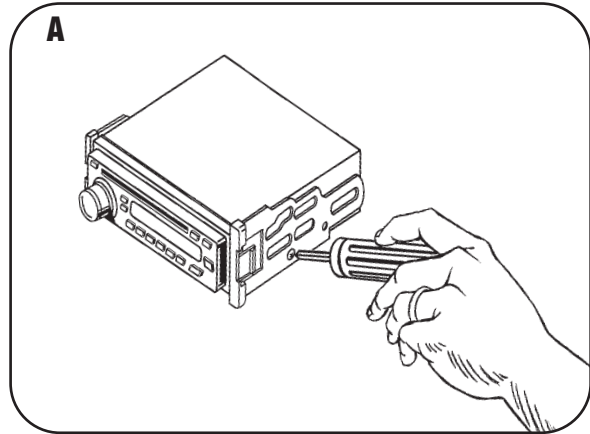

**Note** - When ISO mounted, the radio can be removed with a set of Ford radio removal keys while still in the dash (Metra part # 86-5618, sold separately).

## DOUBLE DIN HEAD UNIT PROVISION

- 1** Cut and remove center divider from radio housing. (Figure A)
- 2** Snap the DDIN brackets to the inside edge of the radio housing. (Figure B)
- 3** Slide the DDIN radio unit into the DDIN bracket/radio housing assembly and secure the unit to the kit using the screws supplied with the head unit. (Figure C)
- 4** Snap the DDIN trim-plate onto the housing/radio assembly. (Figure C)
- 5** Locate the factory wiring harness in the dash. Metra recommends using the proper mating adapter from Metra or AXXESS. Re-connect the negative battery terminal and test the unit for proper operation.
- 6** Snap radio assembly into factory radio opening.

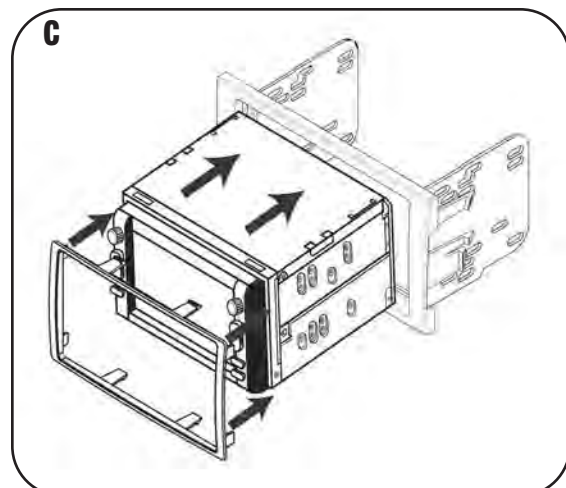
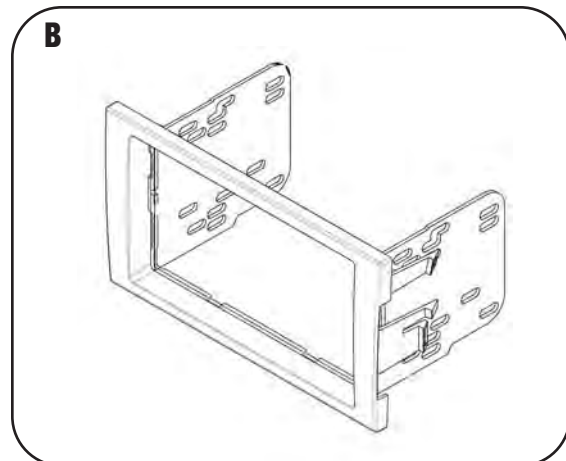
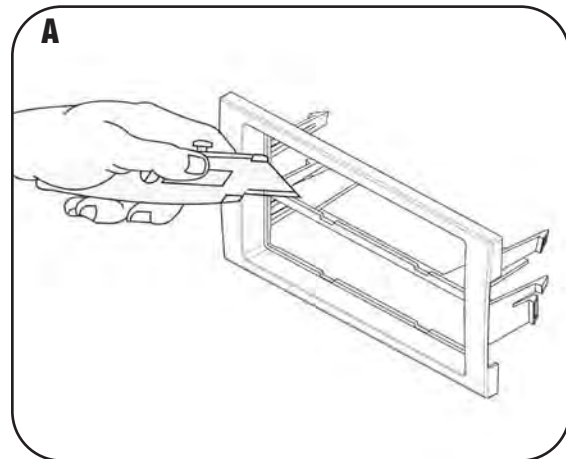



# 99-9107B INSTRUCTIONS



1-800-221-0932



[www.metraonline.com](http://www.metraonline.com)

REV. 10/26/09

© COPYRIGHT 2004-09 METRA ELECTRONICS CORPORATION

INST99-9107B