



INSTALLATION INSTRUCTIONS FOR PART 99-9225

APPLICATIONS

**Volvo XC90
2003-2008**

99-9225

KIT FEATURES

- DIN Head Unit Provisions with Pocket



KIT COMPONENTS

A) Radio Housing

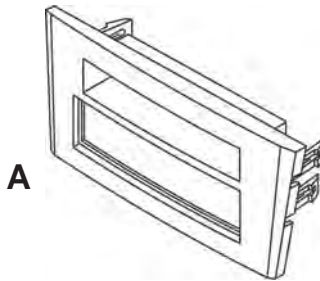

TOOLS REQUIRED:

Flat Blade Screwdriver • (Other Tools May be Required)

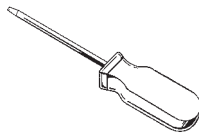

1-800-221-0932



www.metraonline.com

© COPYRIGHT 2004-2009 METRA ELECTRONICS CORPORATION



99-9225

TABLE OF CONTENTS

<i>Dash Disassembly</i>	1
<i>Kit Assembly</i>	2
<i>Final Assembly</i>	3
<i>Notes</i>	4-5



KNOWLEDGE IS POWER

Enhance your installation and fabrication skills by enrolling in the most recognized and respected mobile electronics school in our industry. Log onto www.installerinstitute.com or call 800-354-6782 for more information and take steps toward a better tomorrow.

2003-2008 VOLVO XC90

DASH DISASSEMBLY

- 1 Disconnect the negative battery terminal to prevent an accidental short circuit.
- 2 Move the shifter to the rearmost position, unsnap the shifter trim and move it to one side. (Figure A)
- 3 Remove two screws from bottom of the radio/ climate control cluster. **CAUTION:** Do not remove connectors before turning the ignition off. (Figure B)
- 4 With radio and climate controls out, remove four screws holding the radio to the bracket, release the clips and remove the radio. (Figure C)

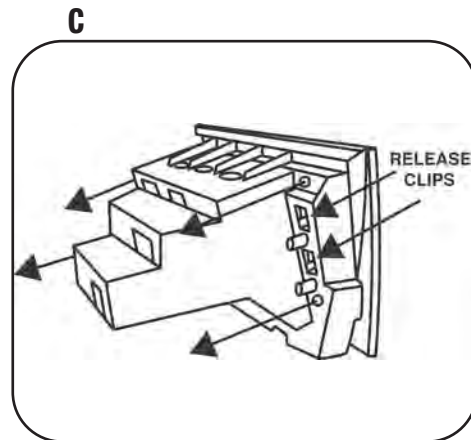
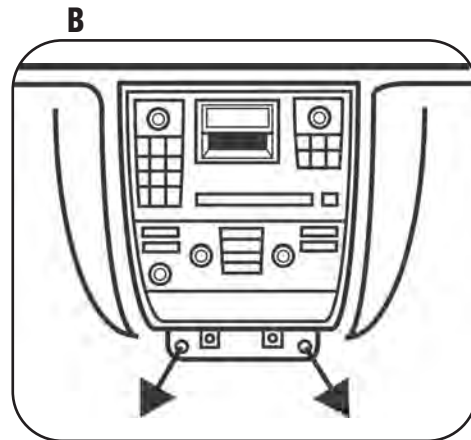
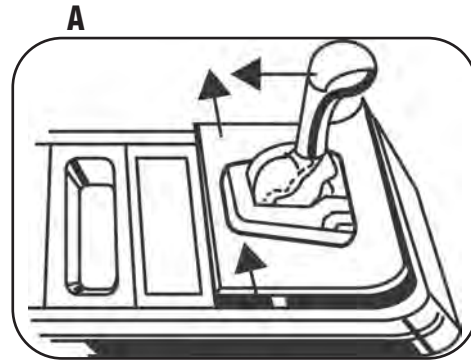

DIN HEAD UNIT PROVISIONS:

- 1 Slide the DIN cage into the Radio Housing and secure by bending the metal locking tabs down. (Figure A)
- 2 Slide the aftermarket head unit into the cage and secure. (Figure B)

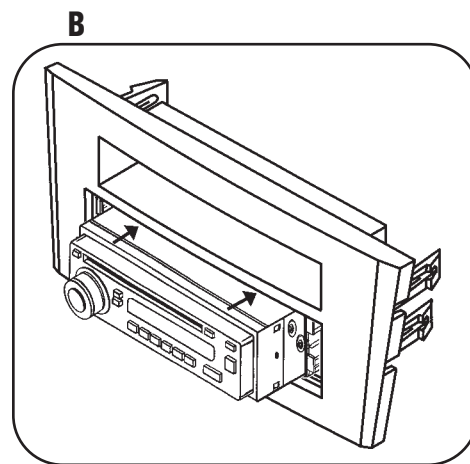
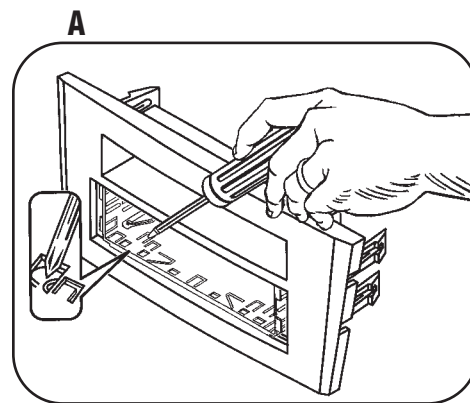

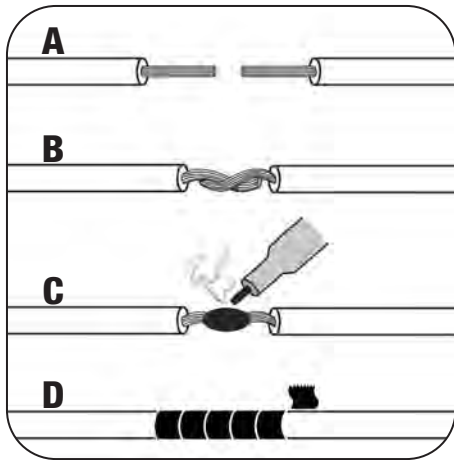

- A) Strip wire ends back 1/2"*
- B) Twist ends together*
- C) Solder*
- D) Tape*

- 1** Locate the factory wiring harness in the dash. Metra recommends using the proper mating adapter and making the connections as shown. (Isolate and individually tape off the ends of any unused wires to prevent electrical short circuit)
- 2** Re-connect the negative battery terminal and test the unit for proper operation.
- 3** Reassemble radio and dash assemblies in reverse order of disassembly.

FINAL ASSEMBLY



99-9225

NOTES

A large rectangular area with a thin black border, containing 25 horizontal lines for writing notes.

99-9225 INSTRUCTIONS



1-800-221-0932



www.metraonline.com

REV. 04-16-09

© COPYRIGHT 2004-2009

METRA ELECTRONICS CORPORATION

INST99-9225