

KIT FEATURES

- ▶ DIN head unit provisions



99-9301

INSTALLATION INSTRUCTIONS

KIT COMPONENTS

Radio Housing

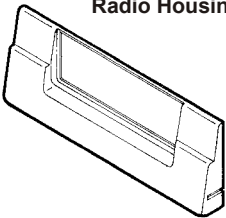

APPLICATIONS

CAR

PAGE

BMW

5 Series 1997-03.....	1-2
X5 2000-06.....	1-2

TOOLS REQUIRED



Torx-head screwdriver



ALL VEHICLES

1

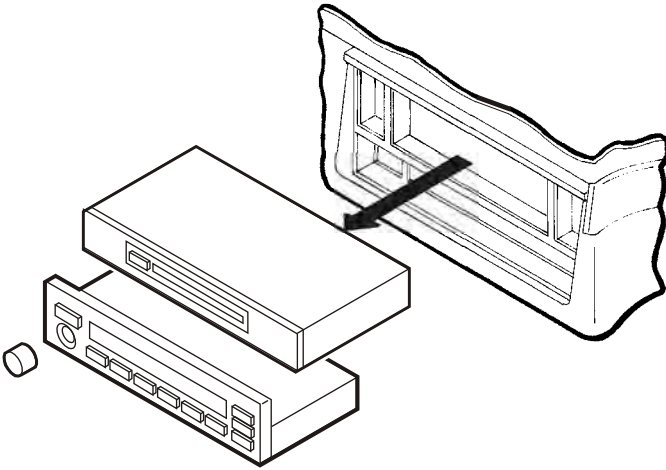

Disconnect the negative battery terminal to prevent an accidental short circuit. Remove the volume knob. Using a T-10 torx-head screwdriver, turn the release lever under the shaft 90°. Leaving the screwdriver in position, pull out on the bottom of the factory head unit and remove the unit. Disconnect the wiring. Using a T-10 torx-head screwdriver, loosen (2) T-10 torx-head screws located beside the head unit guides and remove the top of the factory head unit. Disconnect the wiring.

2

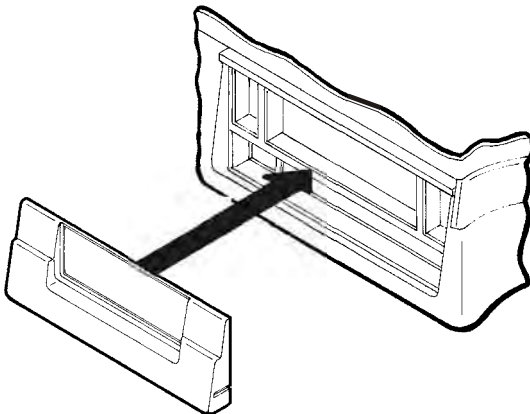

Snap the Radio Housing into the dash opening.

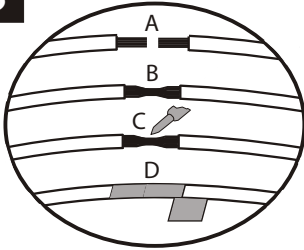
3

- A) Strip wire ends back ½"
- B) Twist ends together
- C) Solder
- D) Tape

Locate the factory wiring harness in the dash. Metra recommends using the proper mating adaptor and making connections as shown. (Isolate and individually tape off the ends of any unused wires to prevent electrical short circuit).

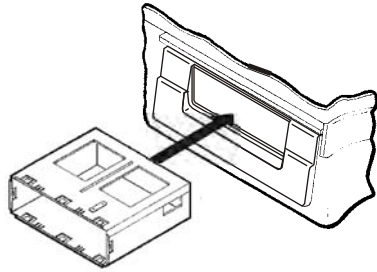
4

Slide the DIN cage into the dash cavity and secure by bending the metal locking tabs down.

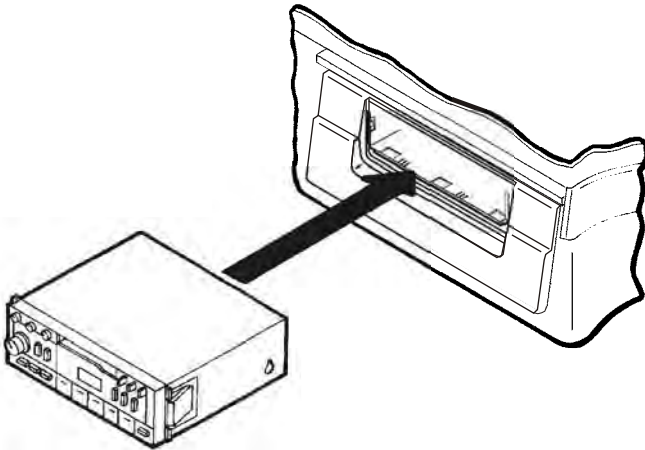
5

Slide the aftermarket head unit into the DIN cage until secure. Re-connect the battery terminal and test the unit for proper operation.