

2010 FORD MUSTANG - V8 4.6L

Warning: When working on, under, or around any vehicle exercise caution. Please allow the vehicle's exhaust system to cool before removal, as exhaust system temperatures may cause severe burns. If working without a lift, always consult vehicle manual for correct lifting specifications. Always wear safety glasses and ensure a safe work area. Serious injury or death could occur if safety measures are not followed.

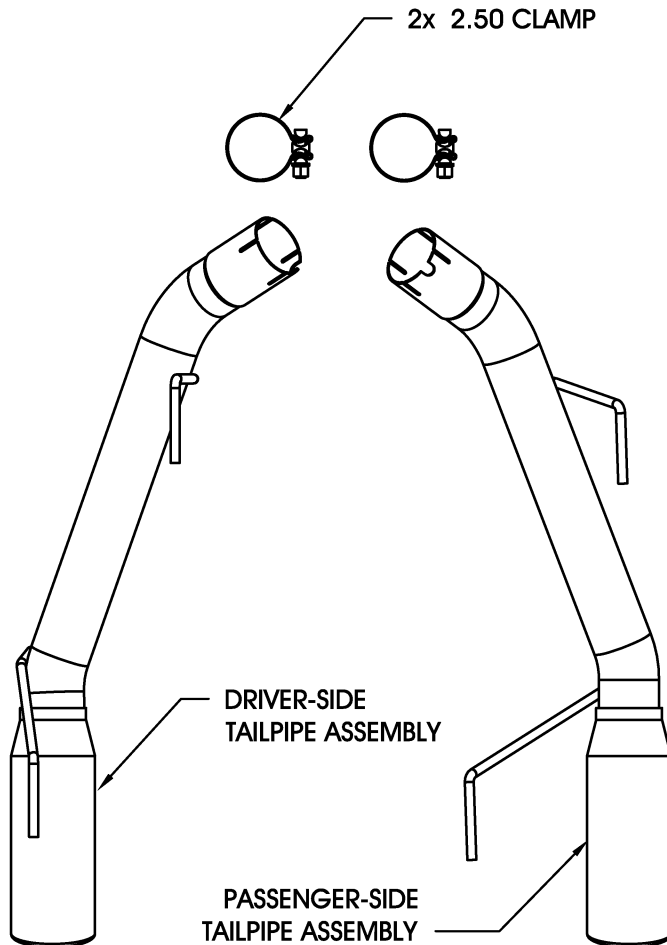

Step 1: (Carefully read all instructions before installation) Disconnect the vehicle's battery before removal of the OEM exhaust. This will allow the computer to reset itself with the new system, and prevent electrical accidents. Loosen the clamps that fasten the OEM mufflers to the over-axle pipes. Disengage the welded hangers from the rubber insulators and remove the mufflers from the vehicle. It may be easier to unbolt the rubber insulator mount brackets and fit them to the new mufflers before attempting to install them on the vehicle.

Step 2: Fasten the new Tailpipe Assemblies to the over-axle pipes using the supplied 2.50" clamps, making sure to line up the pegs and notches. Leave all clamps and fasteners loose for final adjustment of the complete system. If you removed the rubber hanger mount brackets, loosely reinstall them.

Step 3: With all components mounted loosely, adjust the system for overall aesthetics and clearance of frame & bodywork. (It is recommended that at least 1/2" of clearance is maintained between the exhaust system and any body panels to prevent heat-related body damage or fire.)

Step 4: Once a final position has been chosen for the new system, evenly tighten all fasteners from front to rear. The supplied band clamps must be VERY tight to properly align the pipes and prevent leaks (Approximately 40ft-lbs). Inspect all fasteners after 25-50 miles of operation and retighten if necessary.