

Chevrolet & GMC Truck Offset Camber Bushings Installation Instructions

4x2 & 4x4

1999 & Newer Chevrolet Silverado and GMC Sierra 1500 and 2500,
2001 & Newer 1500HD, 2500HD and 3500HD
2000 and Newer Tahoe and Yukon without Auto Ride
2000 & Newer Suburban and Yukon XL 1500 & 2500 without Auto Ride
2002 and Newer Chevrolet Avalanche 1500 & 2500
2002 and Newer Cadillac Escalade
2002 and Newer Hummer H2

NOTE: Offset Camber Bushings must be installed in pairs to supplement OE adjustment range, when alignment specifications cannot be achieved.

Pre Checks:

Perform pre alignment checks in a normal manner.

Take alignment readings to determine if the right or left side needs the most correction. Proceed to install product on that side first.

General Instructions (All Models)

1. Raise vehicle in a safe manner.
Note: Vehicle must be supported under the lower control arms with an appropriate safety device.
2. Remove wheel assembly.
3. Remove brake line brackets from upper control arm.
4. Uncouple plastic fastener and remove ABS line from control arm.
5. Remove and discard both pinned plastic inserts, holding factory-adjusting cams from rotating.
6. Remove upper control arm flange bolts and spin arm 180 degrees to gain access to the control arm bushings.

Removal Instructions: *

 (Using Optional "C-Clamp" Adapter Kit)

7. Install receiver tube over large end of bushing and install extractor plug on small end of bushing. (See Fig. 1 & 2)
8. Install open eyelet of ball joint press over the extractor plug. Holding the ball joint press in a level position, snug screw assembly.
9. Check Alignment of all components, then using steady pressure from an impact gun to remove bushing.
10. Check and clean control arm eyelets of any burs or rust as needed.

Note: (1/2, 3 / 4 & 1Ton, HD Models, Hummer H2 Models) The Control arm has a double eyelet at each end, a spacer is needed which is placed between these eyelets to (To Prevent bending)when removing and installing control arm bushings. (See Fig. 2)

11. Repeat process for other control arm bushings.

See Other side for Installation instructions →

FIG. 1 (1/2 Ton. Except HD)

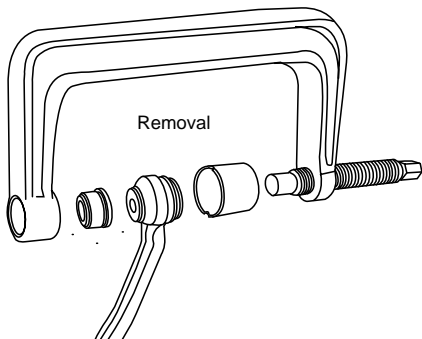
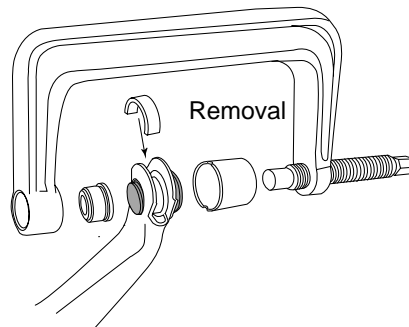

FIG. 2 (1/2. 3 / 4. & 1 Ton HD Series)



*Contact your parts supplier for optional Adapter Kit

Installation Instruction:

Installation Note: On the large end cap of each replacement bushing is stamped a reference arrow. Replacement bushings need to be installed in pairs having each reference arrow pointing in the same direction with the bolt holes in line with each other. This is to insure that the control arm swings up and down in an arc and the pivot points are level to each other. (See Fig. 5 & 6)

Having indicating arrows on the offset bushings horizontally pointing towards control arm ball joint results in a **negative (-) Camber change**. (See Fig. 5)

Having indicating arrows horizontal pointing away from ball joint results in a **positive (+) Camber change**. (See Fig. 6)

Bushing Installation:

12. Install Receiver tube over small end of bushing, and install installation plug on large end of bushing.
13. Install open eyelet of ball joint press over the receiver tube.
14. Holding ball joint press in a level position push plugs over large end of control arm bushing and snug screw assembly.
15. Check Alignment of all components, then using steady pressure from an impact gun Install the bushing.
16. Repeat process for other control arm bushings.
17. Reinstall the ABS line to the upper control arm.
18. Reinstall the brake line brackets to the upper control arm.
19. Reinstall the wheel assembly.
20. Proceed with alignment and road test vehicle.

FIG. 3 (1/2 Ton. Except HD)

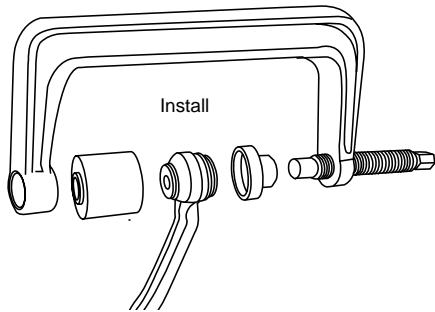

FIG. 5

FIG. 4 (1/2. 3 / 4. & 1 Ton HD Series)

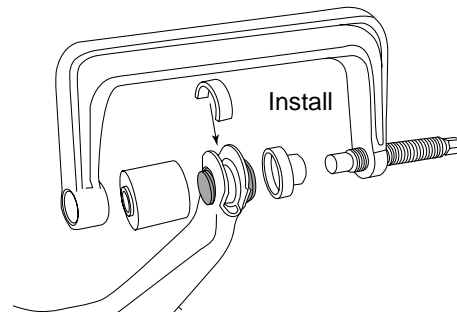

FIG.6

