



**Superlift® 6" standard lift system for 2011 and Newer
FORD F-250 / F-350 SUPER DUTY 4WD
INSTALLATION INSTRUCTIONS**

INTRODUCTION

Installation requires a professional mechanic. Prior to beginning, inspect the vehicles steering, driveline, and brake systems, paying close attention to the suspension link arms and bushings, anti-sway bars and bushings, tie rod ends, pitman arm, ball joints and wheel bearings. Also check the steering sector-to-frame and all suspension-to-frame attaching points for stress cracks. The overall vehicle must be in excellent working condition; repair or replace all worn parts.

Read instructions several times before starting. Be sure you have all needed parts and know where they install. Read each step completely as you go.

NOTES:

- If vehicle is factory equipped with a 2-piece rear driveshaft, Superlift's Carrier Bearing Drop Kit (#9669), purchased separately, is required.
- This system includes a bracket that allows the factory steering stabilizer cylinder to be retained. Due to the loads and harmonics generated by heavier tires / wheels, we recommend that Superlift's optional dual stabilizer system also be used.
- Special Tools Required:
 - The pitman arm-to-steering sector nut requires a 46mm or 1-13/16" socket.
 - A torque wrench capable of 406 ft. lbs.
- Do not install additional components or modify this system to gain additional suspension height.
- Front end realignment is necessary.
- Speedometer recalibration is recommended if a taller tire is used.
- An arrow on diagrams indicates which direction is toward the front of the vehicle.
- A foot-pound torque reading is given in parenthesis () after each appropriate fastener.
- Prior to drilling or cutting, check behind the surface being worked on for any wires, lines, or hoses that could be damaged.
- After drilling, file smooth any burrs and sharp edges.
- Paint or undercoat all exposed metal surfaces.
- Prior to attaching components, be sure all mating surfaces are free of grit, grease, undercoating, etc.
- A factory service manual should be on hand for reference.

- Use the check-off box “☐” found at each step to help you keep your place. Two “☐☐” denotes that one check-off box is for the driver side and one is for the passenger side. Unless otherwise noted, always start with the driver side.

PARTS LIST ... The part number is stamped into each part or printed on an adhesive label. Identify each part and place the appropriate mounting hardware with it.

PART NO.	DESCRIPTION	ATTACHING HDW.	HDW.
	(Qty.- if more than one)	(Qty.- if more than one)	BAG #
01-296	(2) front coil spring, diesel or V-10 gas engines		
OR			
01-297	(2) front coil spring, V-8 gas engine		
01-1116	pitman arm	cotter pin	77-9066-1
		30mm x 1.5 nut	
55-17-9026	compression dampener	(2) 3/8" x 1-1/2" bolt	77-9066-1
	bracket for driver side, front	3/8" x 1" bolt	
		(3) 3/8" SAE washer	
		(3) 3/8" nyloc nut	
55-18-9026	compression dampener	(2) 3/8" x 1-1/2" bolt	77-9066-1
	bracket for pass. side, front	3/8" x 1" bolt	
		(3) 3/8" SAE washer	
		(3) 3/8" nyloc nut	
55-01-9066.....	(2) radius arm drop bracket	(4) 18mm x 130mm bolt.....	77-9066-1
		(8) 18mm washer	
		(4) 18mm nyloc nut	
		(4) 1-1/8" OD x 2-3/4" sleeve	
		(2) 1/2" x 1-1/4" bolt	
		(2) 1/2" SAE washer	
		(2) 1/2" nyloc nut	
55-05-9024.....	(2) track bar key		77-9066-1
55-03-9066.....	track bar bracket, front		
55-01-9074.....	track bar bracket spacer		
55-03-9074.....	(2) front sway bar drop brackets..	(4) 7/16" x 1-1/2" bolt.....	77-9074
		(8) 7/16" SAE washer	
		(4) 7/16" nyloc nut	
55-04-9066.....	steering stabilizer bracket		

PART NO.	DESCRIPTION (Qty.- if more than one)	ATTACHING HDW. (Qty.- if more than one)	HDW. BAG #
55-09-9074 rear brake line bracket	(1) 7/16" x 1" bolt (2) 7/16" SAE washer (1) 7/16" nyloc nut	
55-05-9074 front brake line bracket, dr side		
55-06-9074 front brake line bracket, pa side		
	(2) shock absorber, front.....	(2) hardware pack, boot tie	
	(2) shock absorber, rear.....	(2) hardware pack, boot tie	
00461.....	decal, "Warning To Driver"		
00421.....	decal, Superlift® die-cut		
55-05-9066 (2) anti-sway bar link, rear.....	(4) hourglass bushing 77-9066-2 (4) 5/8" OD x 1.48" sleeve (4) 12mm x 70mm bolt (4) 1/2" USS washer	

FRONT INSTALLATION PROCEDURE

NOTE: Save all factory components and hardware for reuse, unless noted.

- 1) **TRACK BAR...** Prior to raising the vehicle, disconnect the track bar from its frame attachment point, and let the bar hang.
- 2) **ANTI-SWAY BAR...** Disconnect the sway bar brackets from the frame.
- 3) **JACK STANDS...** Place vehicle in neutral. Raise front of vehicle with a jack and secure a jack stand beneath each frame rail, behind the radius arm mounts. Ease the frame down onto the stands, place transmission in low gear or "park", and chock rear tires. Remove front tires.
- 4) **SHOCK ABSORBERS...** Position a jack so that it supports, but does not raise, the front axle. Remove shocks.
- 5) **STEERING STABILIZER [SEE PHOTO]...**
 - Remove the steering stabilizer cylinder then unbolt the factory steering stabilizer bracket from the crossmember.
 - Position the steering stabilizer bracket to the track bar crossmember and fasten with the supplied 1/2" hardware. Attach the stabilizer to the steering stabilizer bracket (#55-04-9066) and tighten until bushings swell slightly.

6) DRAG LINK... Remove the cotter pin, castellated nut cover and nut attaching the drag link-to-pitman arm. Using the appropriate puller tool, separate the drag link from the pitman arm.

7) BRAKE HOSE BRACKETS, VACUUM LINE... Perform on each side:

A bracket attaches the brake line / hose assembly to the outboard face of the frame rail, just forward of the coil spring tower. Unbolt this bracket from the frame.

The rubber brake hose's lower end, and the 4WD activation vacuum line, are attached to the front axle via a bracket located in front of the coil spring's lower seat. Unplug the vacuum line where it passes through this bracket then unbolt the bracket from the axle.

8) REMOVE COILS... Carefully lower the front axle enough to facilitate coil springs' removal. Save the rubber isolators, located on top of the coils, for re-use.

9) TRACK BAR BRACKET ... Unbolt the factory track bar bracket from the frame.

10) PITMAN ARM...

NOTE: The pitman arm-to-steering sector nut requires a 46mm or 1-13/16" socket, not a box-end wrench. A torque wrench capable of 350 ft. lbs. is also required.

Note the pitman arm-to-sector shaft indexing. Remove arm-to-sector nut and, using the appropriate puller tool, remove the arm from the sector shaft.

IMPORTANT: The arm-to-sector nut is for "one time use" only. Discard the factory nut.

IMPORTANT: Thoroughly clean both the steering sector shaft splines and the new pitman arm splines; use paint thinner or brake cleaner.

Position #01-1116 pitman arm onto the sector shaft, in the same orientation as the factory arm, then install the supplied nut (350).

11) TRACK BAR BRACKET...

NOTE: Where this bracket attaches to the crossmember, there is often an excessive amount of undercoating build-up, especially on the back (rearward facing) portion of the crossmember. Scrape-off excessive undercoating to prevent the track bar bracket from loosening over time.

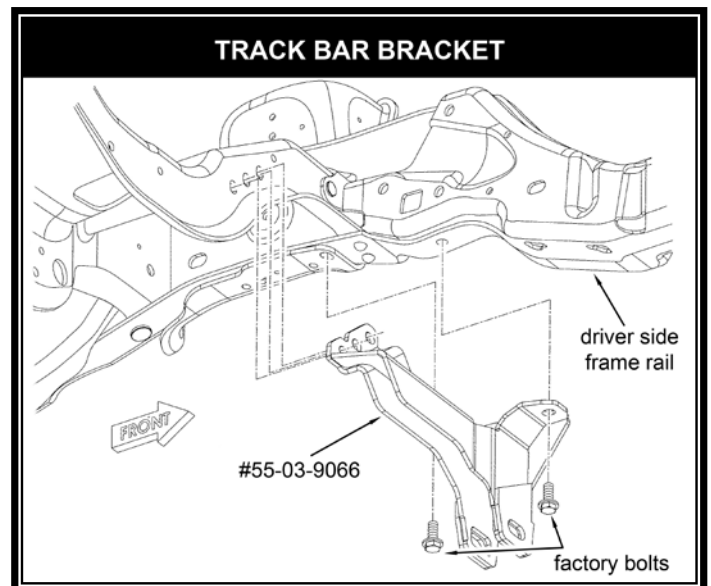
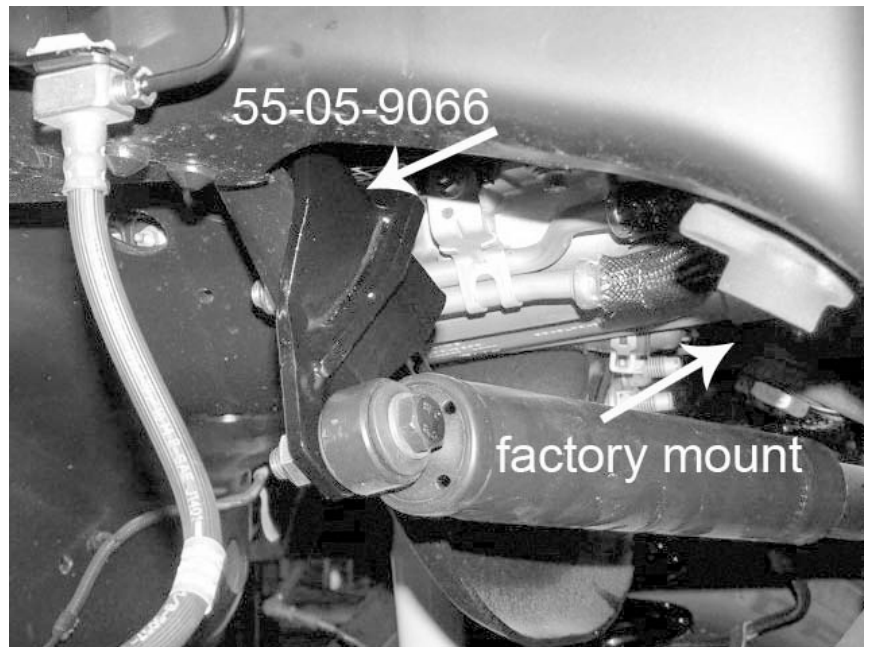

☐ [SEE DIAGRAM] Position the Superlift® track bar spacer (#55-01-9074) between the track bar bracket (#55-03-9066) on the frame on the rear hole in the factory location, and secure using the five factory bolts (136).

12) RADIUS ARMS... Perform step 12 one side at a time. Start on the driver side. **NOTE:** If optional Superlift® 4-link conversion is being used, install it now per separate instructions.

☐☐ An ABS wire is attached to each arm via two push-in grommets; detach these grommets from the arm. Unplug the ABS wire at its frame connector.

☐☐ Verify that the axle is supported by the jack then unbolt the radius arm from the frame and front axle.

☐☐ [SEE DIAGRAM] Position the radius arm drop bracket (#55-01-9066) inside the factory mount on the frame, as shown. Align the drop bracket's side and rear mounting holes with the existing holes in the factory mount.

☐☐ Install the supplied 1/2" x 1-1/4" bolt, SAE washer and nyloc nut in the rear hole. Install bolt from the front, pointing rearward, with the washer on the nut side. Do not tighten at this time.

☐☐ Position the supplied 1-1/8" OD x 2-3/4" sleeves inside the drop bracket, and align them with the two mounting holes, as shown. Insert the supplied 18mm x 130mm bolts through the factory mount, drop bracket, and sleeves. Install bolts from the outside facing in, with supplied washers on both sides. Do not tighten at this time.

☐☐ Attach the radius arm-to-drop bracket. Insert factory bolt from the outside, facing in. Snug-up, but do not fully tighten. This bolt is not tightened until the suspension is supporting vehicle weight.

☐☐ Tighten Superlift® drop bracket-to-factory frame mount hardware: 1/2" bolt (57) followed by the 18mm bolts (200). Again, do not tighten the radius arm-to-bracket bolt yet.

Perform step 12 on opposite side.

RADIUS ARM DROP BRACKETS - Driver side shown.

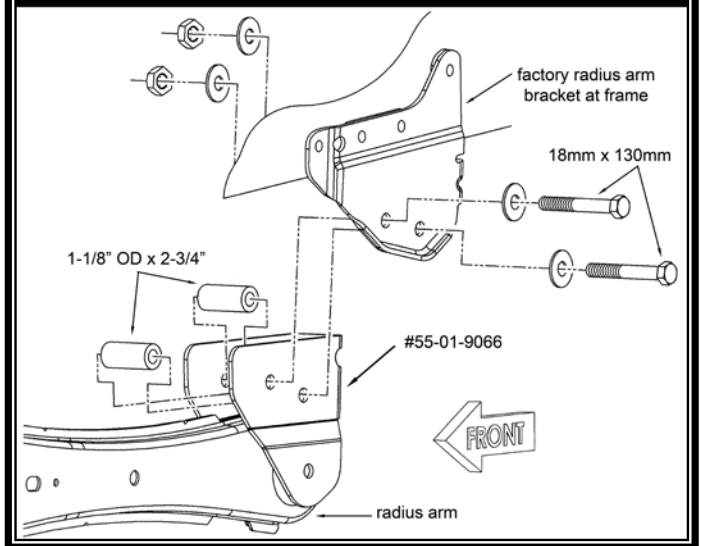

COMPRESSION DAMPENER BRACKETS

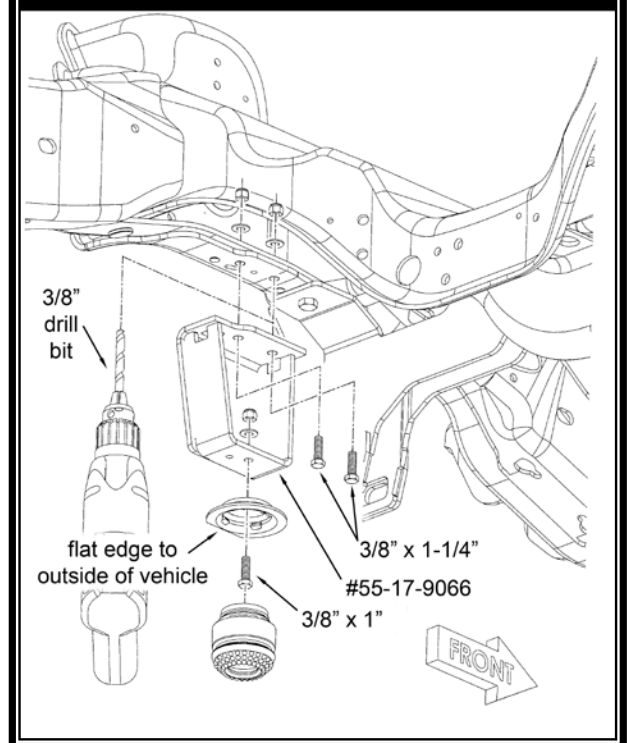

13) COMPRESSION TRAVEL DAMPENER BRACKETS... [SEE DIAGRAM] Perform step 13 one side at a time. Start on the driver side.

Pry the front compression travel dampeners out of its mounting cup then unbolt the cup from the frame.

Note that bracket #55-17-9026 is for driver side; #55-18-9026 is for passenger side. Position bracket #55-17-9026 onto frame, in the factory cup's location. There are two recesses in the bracket that align with two existing frame rivets. Also note that the bracket's inside edge is contoured to match a similar edge on the frame. Align the two contoured edges, then using the bracket as a template, mark the location for two mounting holes to be drilled.

Drill the two marked locations using a 3/8" drill bit. Also drill-out the mounting hole in the factory compression stop cup to 3/8".

Attach the Superlift® bracket-to-frame using the supplied 3/8" x 1-1/2" bolts, pointing up, as shown. Place the washers on the frame side, install nyloc nuts and tighten (23).

Position the factory cup onto the Superlift® bracket. Insert the cup's alignment tab into the secondary hole in the Superlift® bracket. The cup should mate flush with the bracket, and its flat edge facing outboard, as shown.

Insert the supplied 3/8" x 1" bolt through the cup and bracket. Install washer and nyloc nut (23).

Press the factory compression dampener back into the mounting cup.

Perform step 13 on opposite side.

14) COIL SPRINGS... Install the coil springs. Be sure that coils' lower ends are indexed / seated properly. Position a factory rubber isolator on top of each coil then raise the axle just enough to seat the coil springs into the coil towers.

15) SHOCK ABSORBERS...

Install the bushings, sleeves, and boots onto the Superlift® shock absorbers.

Use the jack to raise the axle and compress the coil springs just enough to install the shocks. Secure the upper (stem) end using the supplied bushing, washer and nut then tighten until the bushings swell slightly. Attach, do not tighten, the lower end of shock-to-axle. This bolt is not tightened until the suspension is supporting vehicle weight.

16) BRAKE HOSES... NOTE: Perform these steps one side at a time. Start on the passenger side.

[SEE DIAGRAM] Factory brackets

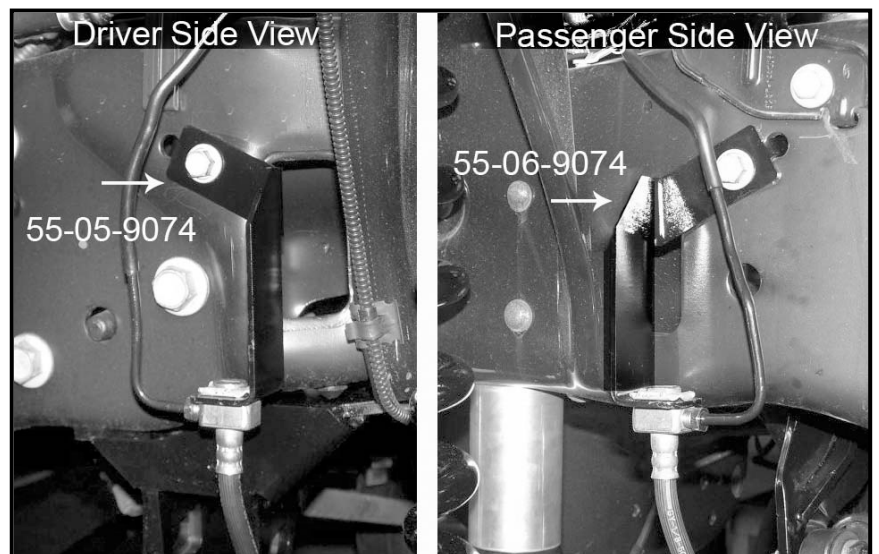

secure the brake hoses to the frame; these brackets were unbolted from the frame during disassembly. Completely remove the frame-mounting bracket from the brake hose by removing the horseshoe clip. Gently loosen the fitting between the hard line and the rubber hose just enough to rotate the hose so that it is pointing downward.

Attach the new brake line brackets (#55-05-9074 driver side, 55-06-9074 passenger side) to the factory location using the factory hardware with the brake hose on the bottom side.

Re-attach the lower brake hose brackets to the axle using the factory hardware and tighten (9).

17) STEERING STABILIZER...

Install stabilizer cylinder; tighten until bushings swell slightly.

18) DRAG LINK... Reattach drag link-to-pitman arm (148) then install castellated nut cap and the supplied cotter pin. **NOTE:** Over-tightening may result in premature wear and / or failure.

19) TIRES / WHEELS... [SEE DIAGRAM] Tighten the lug nuts (148) in the sequence shown.

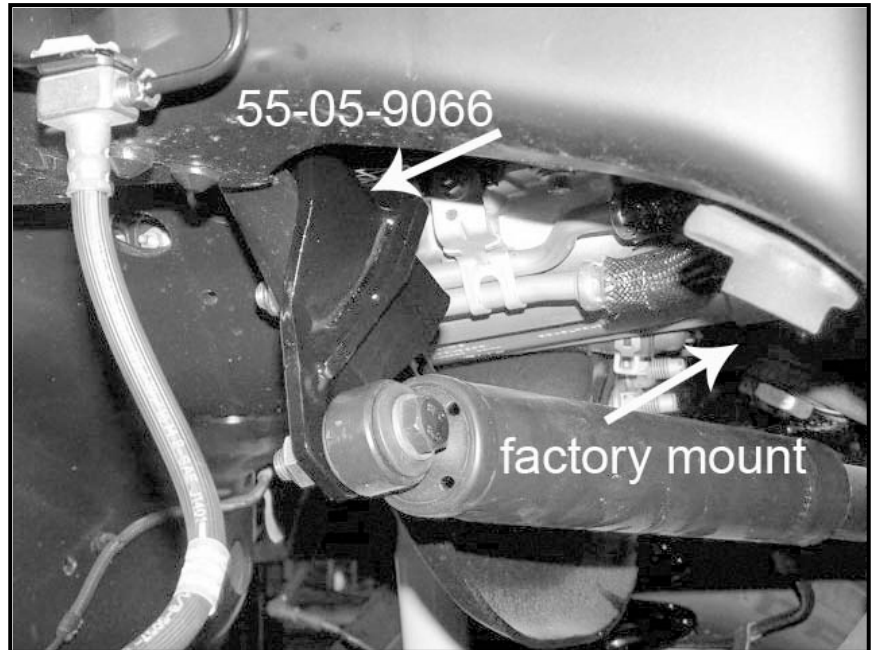

WARNING: When the tires / wheels are installed, always check for and remove any corrosion, dirt, or foreign material on the wheel mounting surface, or anything that contacts the wheel mounting surface (hub, rotor, etc.). Installing wheels without the proper metal-to-metal contact at the wheel mounting surfaces can cause the lug nuts to loosen and the wheel to come off while the vehicle is in motion.

WARNING: Retighten lug nuts at 500 miles after any wheel change, or anytime the lug nuts are loosened. Failure to do so could cause wheels to come off while vehicle is in motion.

20) JACK STANDS... Raise vehicle, remove jack stands and lower vehicle to the floor.

NOTE: The remaining front installation steps are performed with the suspension supporting vehicle weight.

21) RADIUS ARMS... On both sides: Tighten factory bolts that attach radius arms-to-frame and axle (222). Reattach ABS wire-to-arm then reconnect ABS wire at the frame.

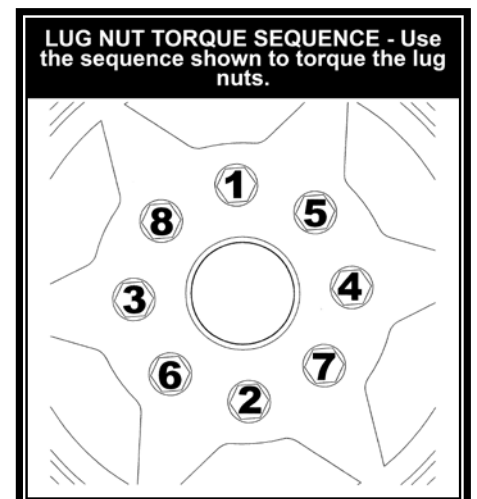

22) TRACK BAR...

- Align the track bar's upper end with the slotted holes in the Superlift® track bar bracket.
- Track bar keys (#55-05-9024) - The hole in each of the two keys is offset to one side. Insert the keys into the slots in the Superlift® bracket so the key holes are offset towards the driver side. Insert the factory track bar bolt and tighten (406).

IMPORTANT: Yes, the proper torque specification for the track bar eye bolt is 406 lb-ft; this is not a typographical error. If the appropriate torque wrench is not available, tighten the bolt as much as possible then take the vehicle to your Ford Dealer or a heavy equipment repair shop to perform the final torque operation. Proper bolt torque is critical.

- 23) FRONT SHOCK-TO-AXLE BOLT** - On both sides, tighten bolt (136).

24) FRONT ANTI-SWAY BAR BRACKETS...[SEE PHOTO]

- Install the new drop brackets (#55-03-9074) on the frame using the factory hardware. The open part of the "C" should face the outside of the vehicle on the passenger side and the inside on the driver's side. Attach the factory bracket to the new drop bracket using the supplied 7/16" x 1-1/2" hardware.



- 25) INITIAL FRONT CLEARANCE CHECK...** Again, raise the vehicle and place a jack stand under each frame rail just behind the radius arm attaching points. With the suspension "hanging" at full extension travel, cycle steering lock-to-lock and check all components for proper operation and clearances. Pay special attention to the clearance between the tires / wheels and brake hoses, wiring, etc.

- 26) FINAL FRONT CLEARANCE and TORQUE CHECK...** Raise vehicle, remove jack stands and lower vehicle to the floor. Cycle steering lock-to-lock and inspect the tires / wheels, and the steering, suspension, and brake systems for proper operation, tightness, and adequate clearance.

REAR INSTALLATION

- 27) JACK STANDS...** Raise rear of vehicle with a jack and secure a jack stand beneath each frame rail, just in front of the rear springs' front hangers. Ease the frame down onto the stands and chock front tires. Remove rear tires.
- 28) SHOCK ABSORBERS...** Position a jack so that it supports, but does not raise, the rear axle. Remove shocks.
- 29) ANTI-SWAY BAR LINKS...** Not all models are equipped with an anti-sway bar.

Remove hardware securing the anti-sway bar links-to-bar body (at the axle).

30) U-BOLTS... Remove spring-to-axle U-bolts. Use the jack to carefully lower the axle enough to facilitate add-a-leaf installation. Prior to removing factory blocks, note which side they are on, and their front / rear orientation.

31) REAR BRAKE LINE BRACKET... [SEE PHOTO]

Unclip the rear axle vent hose from the top frame lip and re-clip to the bottom frame lip. Remove the rear axle vent hose from the barbed fitting. Remove the barbed fitting. Position the rear brake line bracket (#55-09-9074) under the factory bracket and attach it using the factory barbed fitting. Attach the factory bracket to the Superlift bracket using the supplied 7/16" hardware.

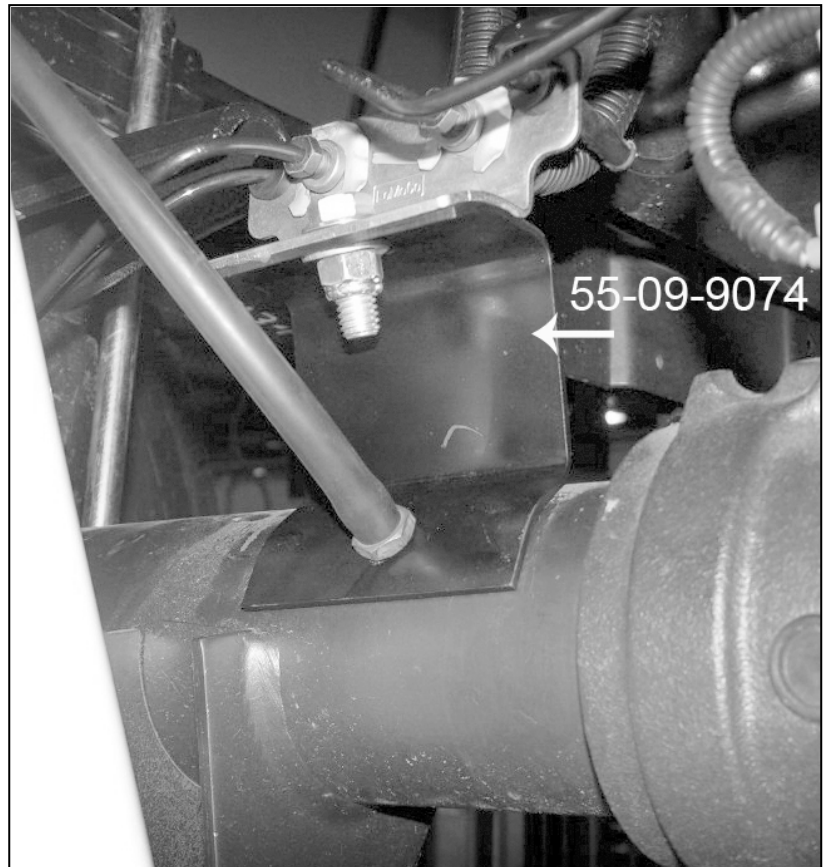

32) BLOCK KIT...

Position Superlift® block onto axle; be sure that tall end of block faces towards rear of vehicle. Position factory block on top of Superlift® block in the same orientation as factory. Be sure all components seat and align properly.

Evenly raise the axle until the factory blocks mate with the springs. Position U-bolt plates on top of spring. Evenly tighten U-bolts using an "X" tightening pattern (145).

33) SHOCK ABSORBERS... Install bushings, sleeves, and boots onto new shocks. Install shocks using the factory hardware. On some models, it is necessary to position a 1/2" SAE washer (supplied) on either side of the lower shock bushing and its mount. Attach, do not tighten, the shock mounting bolts; they are not tightened until the suspension is supporting vehicle weight.

34) ANTI-SWAY BAR LINKS...

Remove hardware securing the anti-sway bar links-to-frame.

Install supplied bushings and sleeves onto Superlift® links (#55-05-9066).

Install Superlift® links using the supplied 12mm x 70mm bolts, washers and factory nuts (80). Note that the links attach to the inboard sides of the bar body, and the outboard sides of the frame.

35) TIRES / WHEELS... Install tires / wheels. Refer to step 19 for warnings and proper torque information. Remove jack stands and lower vehicle to floor.

36) SHOCK ABSORBERS... With the suspension supporting vehicle weight, tighten rear shock mounts (85).

37) REAR CLEARANCE CHECK... Check all components for proper tightness, clearances and operation.

38) CARRIER BEARING DROP KIT... If vehicle is factory equipped with a 2-piece rear driveshaft, Superlift's drop kit, purchased separately, is required. Install per separate instructions.

FINAL PROCEDURES

39) 4WD SYSTEM CHECK... Activate 4WD system and check for engagement.

40) HEADLIGHTS... Readjust headlights to proper setting.

41) SUPERLIFT® WARNING DECAL... Install the WARNING TO DRIVER decal on the inside of the windshield, or on the dash, within driver's view. Review the "IMPORTANT PRODUCT USE AND SAFETY INFORMATION / WARNINGS" text found at the end of this instruction sheet.

42) ALIGNMENT... Realign vehicle to factory specifications.

Limited Lifetime Warranty / Warnings

Your Superlift® product is covered by the Limited Warranty explained below that gives you specific legal rights. This limited warranty is the only warranty Superlift® makes in connection with your product purchase. Superlift® neither assumes nor authorizes any retailer or other person or entity to assume for it any other obligation or liability in connection with this product or limited warranty.

What is covered? Subject to the terms below, Superlift® will repair or replace its products found defective in materials or workmanship for so long as the original purchaser owns the vehicle on which the product was originally installed. Your warrantor is LKI Enterprises, Inc. d/b/a Superlift® Suspension Systems ("Superlift®").

What is not covered? Your Superlift® Limited Warranty does not cover products, parts or vehicles Superlift® determines to have been damaged by or subjected to:

- Alteration, modification or failure to maintain.
- Normal wear and tear (bushings, tie-rod ends, etc.). Scratches or defects in product finishes (powder coating, plating, etc.),
- Damage to or resulting from vehicle's electronic stability system, related components or other vehicle systems.
- Racing or other vehicle competitions or contests. Accidents, impact by rocks, trees, obstacles or other aspects of the environment.
- Theft, vandalism or other intentional damage.

Remedy Limited to Repair / Replacement. The exclusive remedy provided hereunder shall, upon Superlift's inspection and at Superlift's option, be either repair or replacement of product or parts covered under this Limited Warranty. Customers requesting warranty consideration should contact Superlift® by phone (1-800-551-4955) to obtain a Returned Goods Authorization number. All removal, shipping and installation costs are customer's responsibility.

If a replacement part is needed before the Superlift® part in question can be returned, you must first purchase the replacement part. Then, if the part in question is deemed warrantable, you will be credited / refunded.

Other Limitations - Exclusion of Damages - Your Rights Under State Law

- Neither Superlift® nor your independent Superlift® dealer are responsible for any time loss, rental costs, or for any incidental, consequential or other damages you may have.
- This Limited Warranty gives you specific rights. You may also have other rights that vary from state to state. For example, while all implied warranties are disclaimed herein, any implied warranty required by law is limited to the terms of our Limited Lifetime Warranty as described above. Some states do not allow limitations of how long an implied warranty lasts and / or do not allow the exclusion or limitation of incidental or consequential damages, so the limitations and exclusions herein may not apply to you.

Important Product Use and Safety Information / Warnings

As a general rule, the taller a vehicle is, the easier it will roll over. Offset, as much as possible, what is lost in rollover resistance by increasing tire track width. In other words, go "wide" as you go "tall". Many sportsmen remove their mud tires after hunting season and install ones more appropriate for street driving; always use as wide a tire and wheel combination as feasible to enhance vehicle stability. We strongly recommend, because of rollover possibility, that the vehicle be equipped with a functional roll bar and cage system. Seat belts and shoulder harnesses should be worn at all times. Avoid situations where a side rollover may occur.

Generally, braking performance and capabilities are decreased when significantly larger / heavier tires and wheels are used. Take this into consideration while driving. Also, changing axle gear ratios or using tires that are taller or shorter than factory height will cause an erroneous speedometer reading. On vehicles equipped with an electronic speedometer, the speed signal impacts other important functions as well. Speedometer recalibration for both mechanical and electronic types is highly recommended.

Do not add, alter, or fabricate any factory or aftermarket parts to increase vehicle height over the intended height of the Superlift® product purchased. Mixing component brands is not recommended.

SUPERLIFT SUSPENSION SYSTEMS

300 Huey Lenard Loop Rd.
West Monroe, Louisiana 71292
Phone: (318) 397-3000
Sales / Tech: 1-800-551-4955
FAX: (318) 397-3040
www.superlift.com