



INSTALLATION INSTRUCTIONS

Trans4mer Grille Guard/Winch Mount Kit 76139 & 76243 For Chevrolet Silverado 1500

As you read these instructions, you will see **NOTES**, **CAUTIONS** and **WARNINGS**. Each message has a specific purpose. **NOTES** are additional information to help you complete a procedure. **CAUTIONS** are safety messages that indicate a potentially hazardous situation which, if not avoided, may result in minor or moderate injury. A **CAUTION** may also be used to alert against unsafe practice. **WARNINGS** are safety messages that indicate a potentially hazardous situation, which, if not avoided could result in serious injury. **CAUTIONS** and **WARNINGS** identify the hazard, indicate how to avoid the hazard, and advise of the probable consequence of not avoiding the hazard. **PLEASE WORK SAFELY!**

NOTE: This installation requires hole drilling. Make sure you have a drill motor and a sharp 7/16" drill available. Wear safety goggles.

PARTS LIST:

PART NO.	QUANTITY	DESCRIPTION
65495/65496	2	Side Member, Black/Stainless
29365/63688	1	Tube, 1-1/2", Black/Stainless
29366/60326	1	Tube, 2-1/2", Black/Stainless
65488	1	Frame Extension, RH
65489	1	Frame Extension, LH
38782	4	Clamping Strap
65487	2	Upper Bracket
39182	2	Brace
13222	2	Tow Hook, Black
39202	2	Nut with Handle
66142	4	Shim Plate
29146 (black kits only)	2	Nylon Washer, 1-1/2"
29147 (black kits only)	2	Nylon Washer, 2-1/2"

TORQUE SPECIFICATIONS:

BOLT SIZE	TORQUE
3/8 inch	30 lb. ft (40.7 N-m)
7/16 inch	50 lb. ft. (67.8 N-m)
1/2 inch	75 lb. ft. (101.7 N-m)

This WARN Trans4mer system can be customized to give your Chevrolet truck a wide variety of looks, front end protection and winch mounting capability. The system starts with this strong two-tube Grille Guard that attaches to the truck's frame with brackets designed by Warn engineers to handle up to a 9500 lb winch. It is durable and good looking, even as a stand alone Grill Guard, but can be easily upgraded with some great options! You can add a third large size tube (Light Bar) that adds even more protection and includes tabs for mounting auxiliary lights. The tubes can be mounted in a variety of positions to achieve the look and function that you desire. You can mount a Winch Carrier Bracket that provides a permanent mount for a Warn winch. An accent cover is available to dress up the winch carrier. You may also add a Receiver Bracket that will handle the Warn Multi-mount winch system, a draw bar or any other accessory that fits the standard 2 inch receiver tube. Finally, Brush Guards that protect the headlights and front corners of the truck can be easily added to any of the options above.

NOTE: Follow the step by step sequence for fastest installation. Do not securely tighten bolts until directed.

1. Remove the grille and bumper. The grille must be removed first to gain access to the bumper bolts. These are easy to remove if the following procedure is followed:
 - a. Open the hood. Remove the four plastic fasteners which attach the plastic shroud to the top of the grille. Pry up the center pin with a screwdriver, then pry out the fastener.
 - b. Give a sharp pull at each of the four corners of the grill to release snaps.
 - c. Give a sharp pull at extreme outer ends of grille center bar to release snaps. Remove grille.
 - d. Remove the bulb sockets from the back side of the fog lights, if so equipped.
 - e. Remove the bolts from the outer bumper braces just forward of the wheels (15mm head).
 - f. Remove the four remaining bumper bolts (15mm head) and remove bumper.

2. Remove factory tow hooks.

3. Install the right and left Frame Extensions as shown in **Photo 1**. On some trucks, the frame holes may need to be enlarged slightly with a round file. Tighten the bottom bolt first, then the two side bolts.

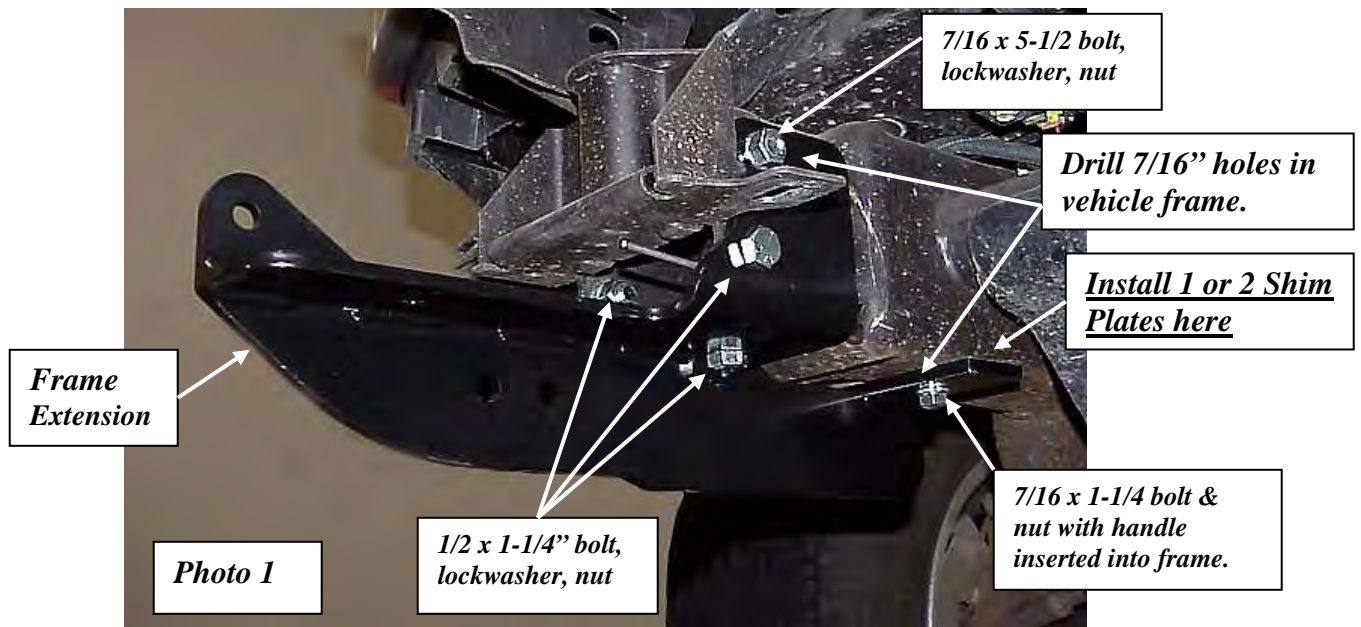

- Using the holes in the Frame Extensions as guides, drill a 7/16" hole thru the bottom of the frame at the rear end of the brackets. Also drill 7/16" holes thru the inboard sides of the frame at the upper front holes. At the rear hole, first **install one or two Shim Plates to fill any space**, then use the "nut with handle" inside the box frame. Install the fasteners and tighten securely.



WARNING



Drilling operations can cause flying metal chips. **WEAR SAFETY GOGGLES.** Flying metal chips can cause eye injury.

- Remove the plastic splash pan/air deflector from the vehicle to expose the tubular front crossmember. Refer to **Photo 2** and loosely install the Clamping Straps around each end of the crossmember.

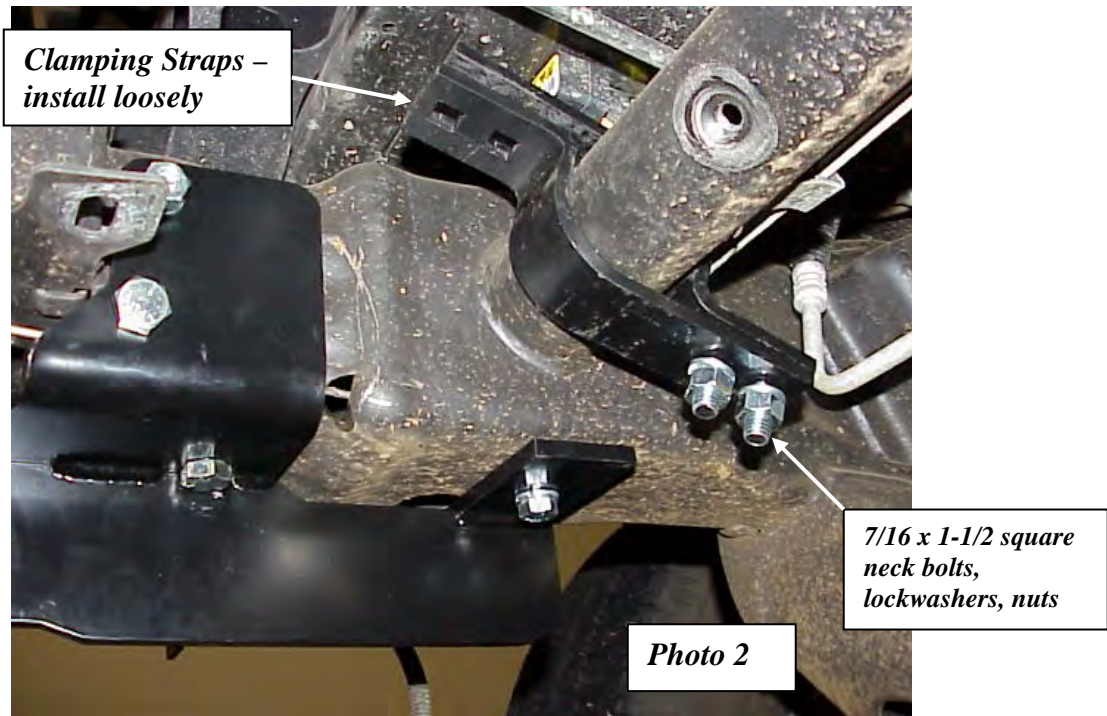

6. Reinstall the bumper and grille. Take care to center the bumper side to side before final tightening. Insert the Upper Brackets thru the bumper slots. Reconnect the fog light bulb sockets.

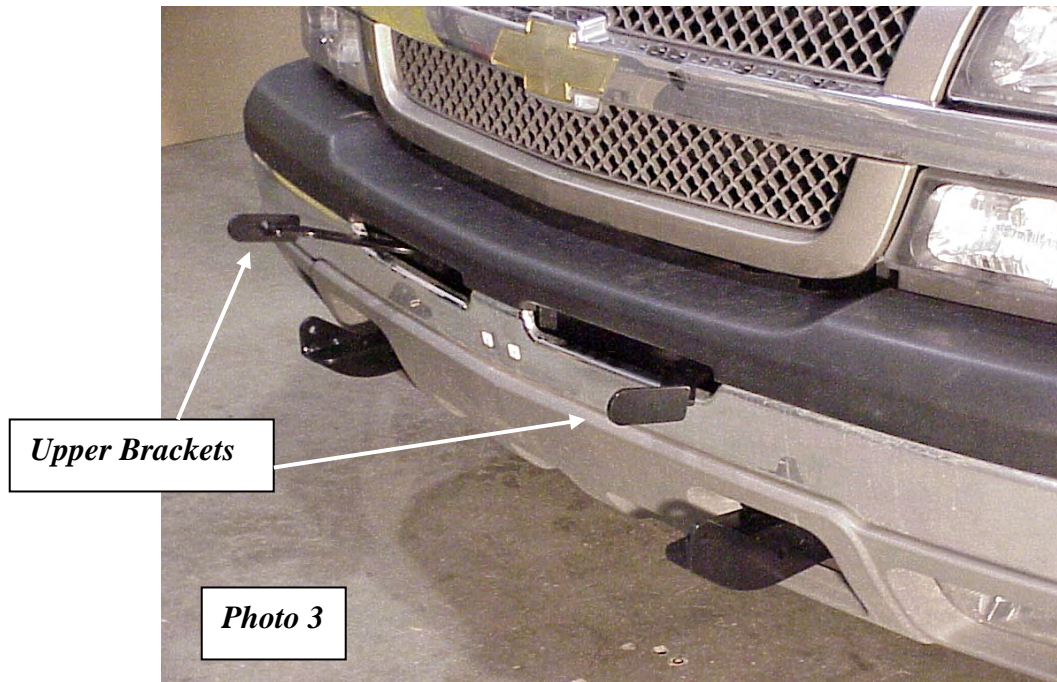

7. Install the Upper Brackets between the Clamping Straps as shown in **Figure 4**. Leave bolts slightly loose.

FIGURE 4

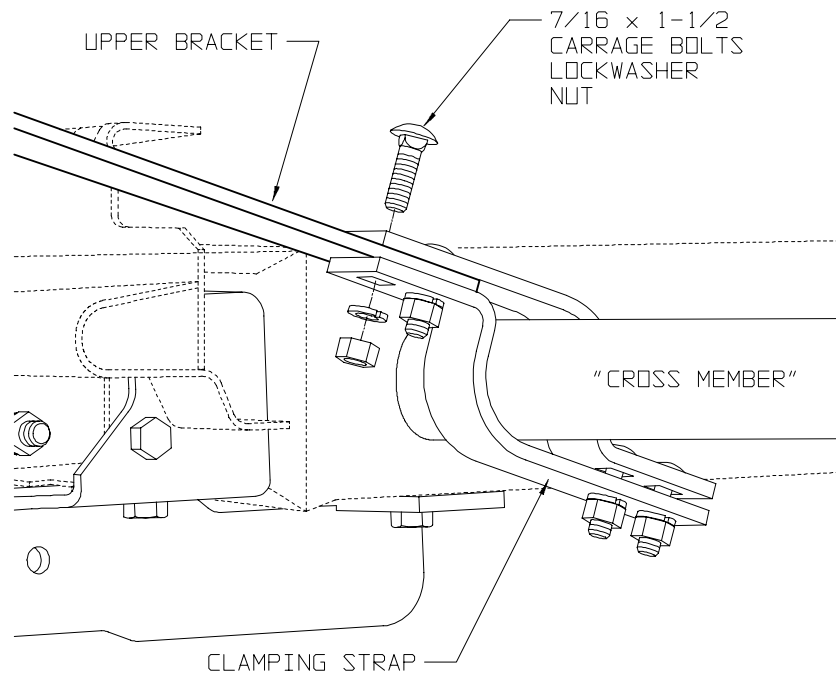

8. Install the Side Members and the supplied Tow Hooks as shown in **Photo 5**. Leave bolts slightly loose.

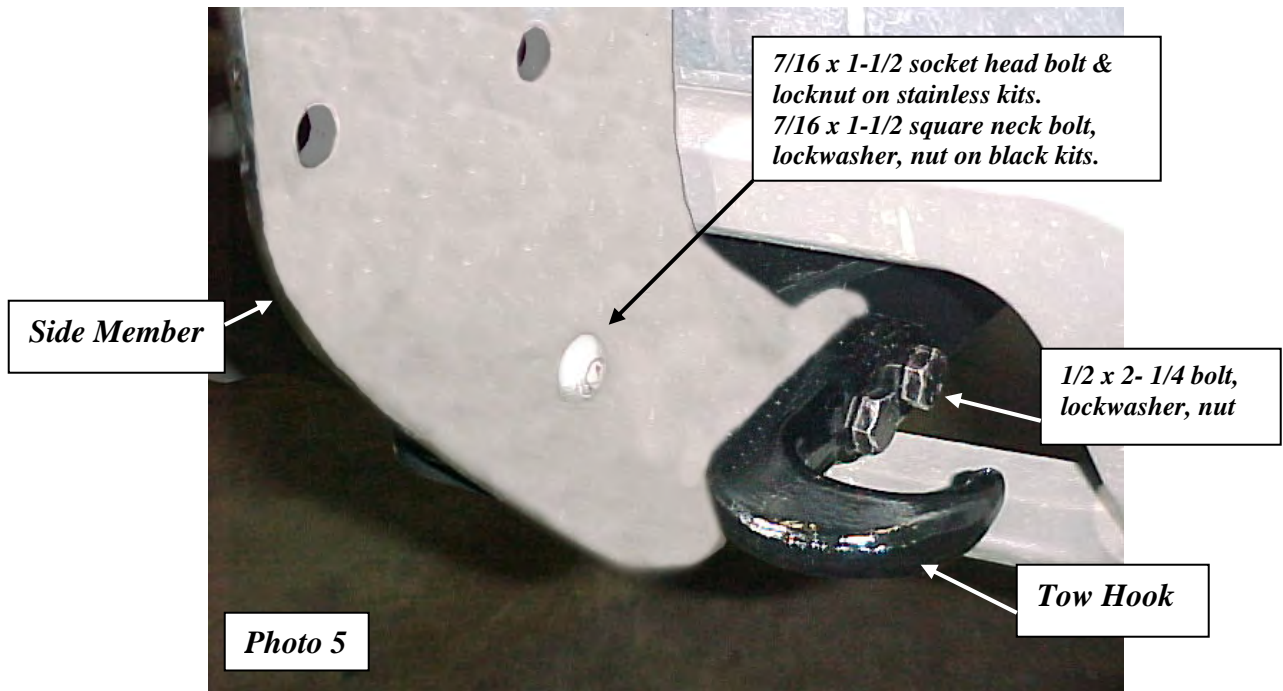

9. Pull the Side members and Upper Brackets forward and mark the outer ends for drilling using the Side Member holes as guides. (**Photo 6**). Remove the brackets and drill 7/16 " holes as marked. Reinstall the brackets and fasteners and tighten securely. Reinstall the splash pan/air deflector.

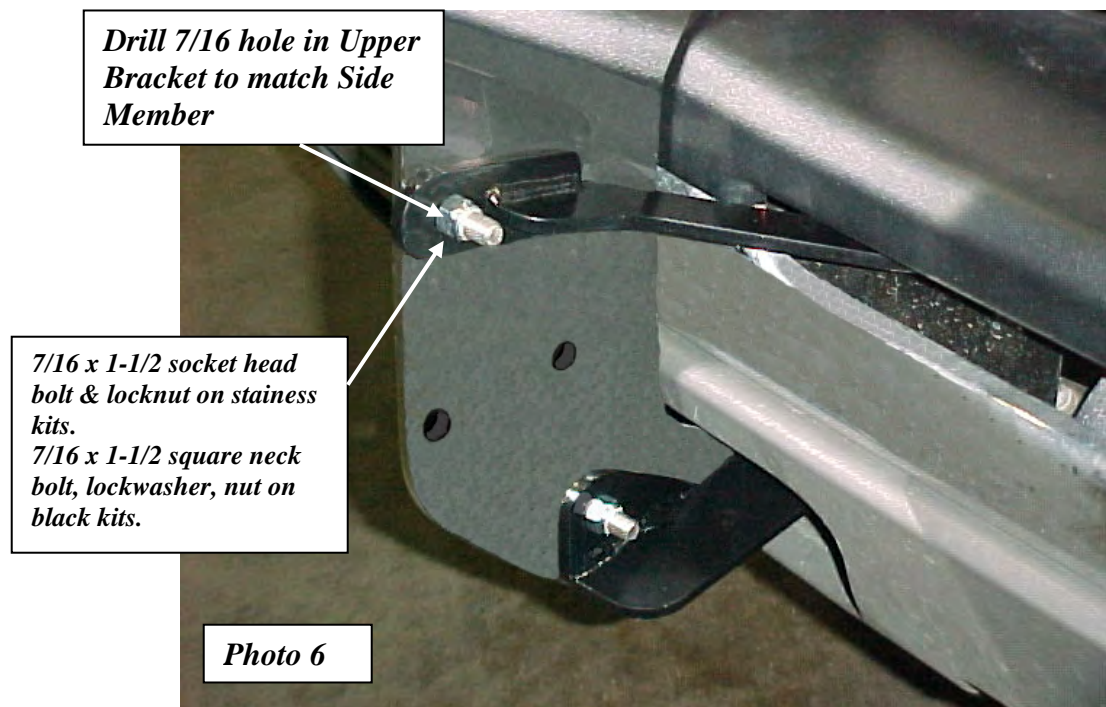

10. Install the large size upper straight Tube to the upper forward holes of the Side Members. Also install the Winch Carrier (if used) at this time. **Leave bolts slightly loose.**

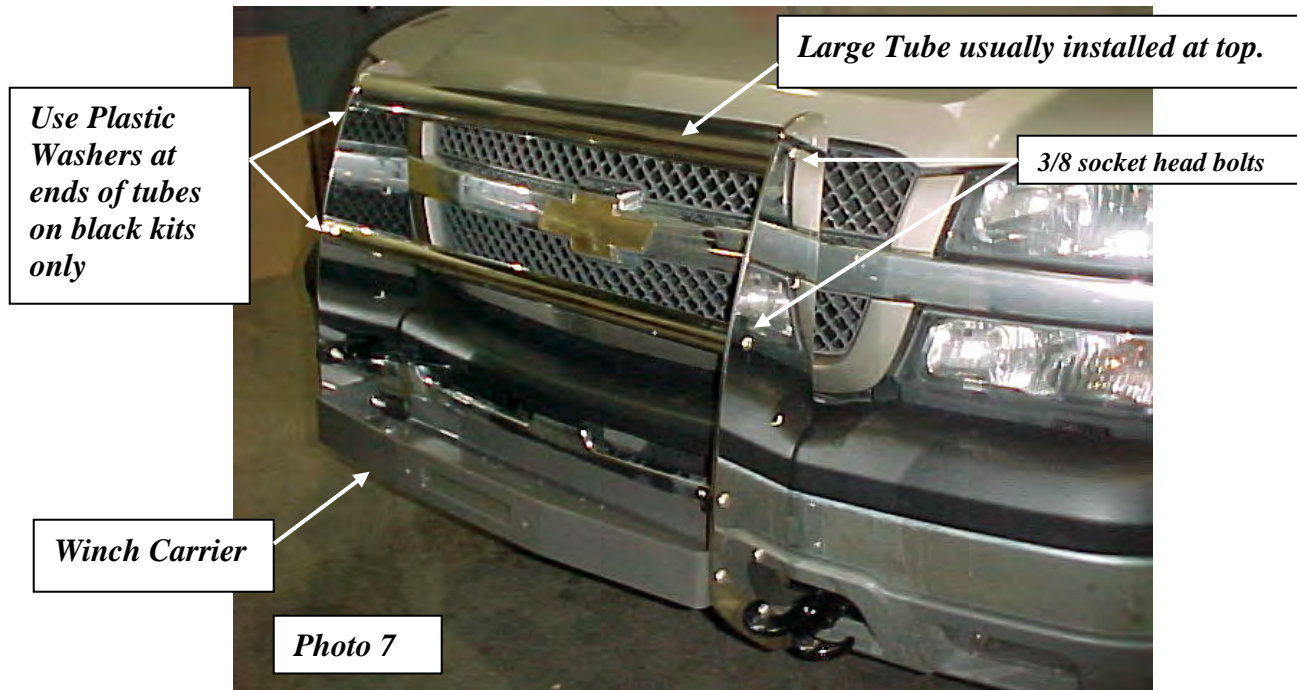

11. The Braces shown in **Photo 8** are required when a winch is being mounted. The forward ends attach in different ways depending on which Winch Carrier is used. If the 29394 Carrier is used, the supplied 1-1/2" bolt will extend up thru the Brace, Carrier and into the winch. When mounting the Receiver, use the bolt with a nut and lock washer in the holes provided. **Leave bolts slightly loose.**

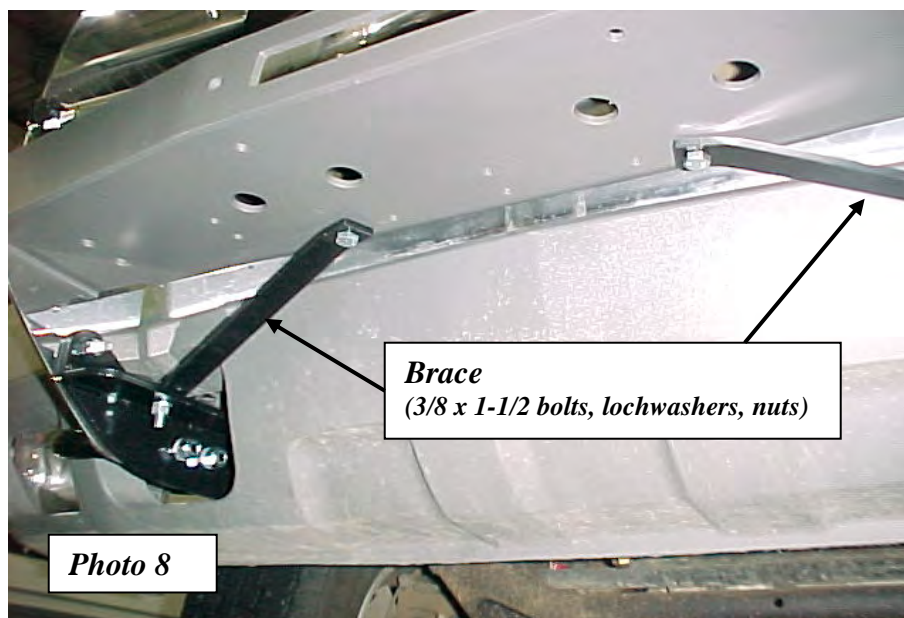

12. Align the Grille Guard assembly with the vehicle and hold it in place while securely tightening all the bolts.

13. Complete the winch installation as described in the instructions packaged with the winch. To connect the battery cables to the side terminal battery, use the supplied fasteners as shown in **Figure 9**. Install the lower straight tube.

FIGURE 9

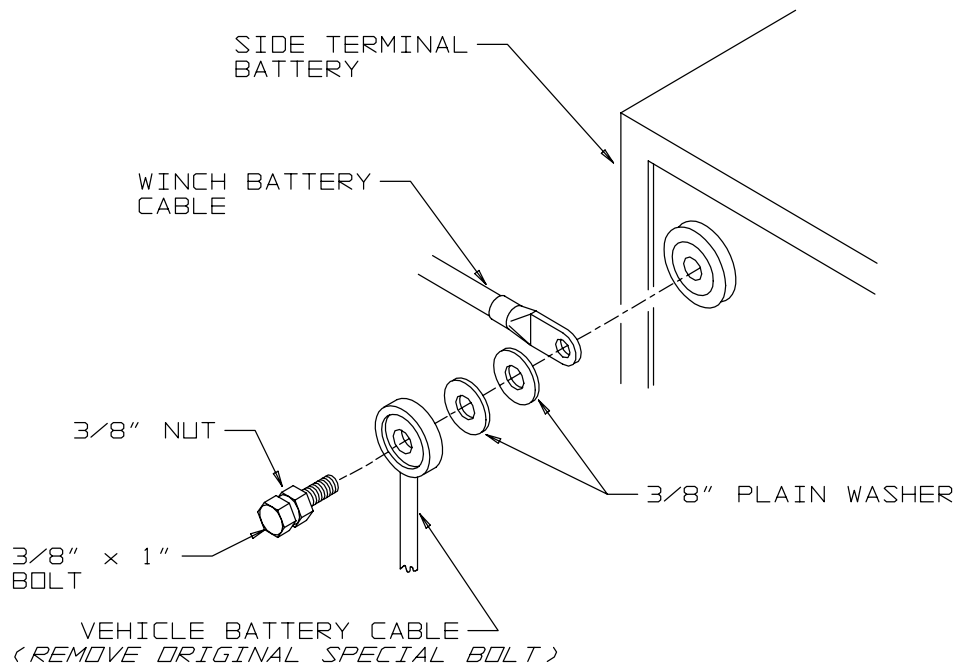

Warn Industries

Stainless Steel Truck Accessories

What to expect:

Polished stainless steel combines the beauty of a chrome-like appearance with extreme durability and corrosion resistance. With a minimum amount of care, the appearance will last almost indefinitely. Unlike platings or coatings, there is nothing to peel off or wear away that would allow corrosion underneath.

The actual appearance may not be exactly like new chrome in either the degree of luster or color. There may be fine polishing lines visible up close and small differences between mating parts of an assembly. A grille guard, for instance, may have small differences between the round tubing and the flat plate. The backside of a part may not be as highly polished as the front. However, part of the beauty and appeal of stainless actually lies in the smooth “hand-worked” appearance.

There also is a possibility that small rust spots can appear on stainless products. They are usually due to minor iron contamination on the surface as a result of normal manufacturing and handling processes. This minor rust, if it occurs at all, is easy to remove and will not tend to spread.

Recommended care:

Regular washing with fresh water and mild car wash detergents followed by rinsing and drying with a soft towel is the best minimum care. Beyond that, any cleaner/wax recommended for automotive finishes will work well to remove minor stains and scuffs, enhance the shine and provide protection. Always use clean soft cotton cloths. In most cases, this will be all that is required for many years. For more serious blemishes or a rust spot, use a cream metal polish recommended for stainless, aluminum, etc. Try to rub in the direction of the original polishing lines.

Ultimately, any stainless part can be restored to a brilliant shine with power buffing processes.

Caution:

Do not use steel wool or any type of metal scraper. Do not use “Scotch Brite” pads or abrasive powdered cleaners. Do not try to clean with muriatic acid or any other acid.

Stainless Fasteners

Stainless steel fasteners are included in many of the stainless kits. These fasteners provide similar corrosion resistance and appearance as the rest of the kit. However, stainless fasteners are prone to galling when installed in similar stainless material. It is a good idea to apply a small amount of anti-seize compound to the threads when installing them. Care should also be taken when tightening the fasteners to prevent rounding or deforming the corners of the bolts. Make sure the wrenches are the correct size and fit properly. In the case of socket heads, the wrench should have sharp, un-worn edges. With a few precautions during assembly the products should provide years of service.