

Air Lift ***PERFORMANCE***

Kit 75699
2008- Scion xB



INSTALLATION GUIDE

For maximum effectiveness and safety, please read these instructions completely before proceeding with installation.

Failure to read these instructions can result in an incorrect installation.



TABLE OF CONTENTS



Introduction	2
Important Safety Notice	2
Notation Explanation	2
Installation Diagram	3
Hardware List	3
Tools List	3
Installing the Air Lift Performance Kit	4
Getting Started	4
Assembling the Air Springs	4
Installing the Air Springs	4
Before Operating	7
Installation Checklist	7
Maintenance and Servicing	8
Minimum and Maximum Air Pressures	8
Maintaining and Operating	8
Replacement Information	8
Warranty and Returns Policy	9
Contact Information	9

Introduction

The purpose of this publication is to assist with the installation, maintenance and troubleshooting of this Scion Air Lift Performance kit.

It is important to read and understand the entire installation guide before beginning installation or performing any maintenance, service or repair. The information includes a hardware list, tool list, step-by-step installation information, maintenance tips, safety information and a troubleshooting guide.

Air Lift Company reserves the right to make changes and improvements to its products and publications at any time. For the latest version of this manual, contact Air Lift Company at (800) 248-0892 or visit our website at www.airliftcompany.com.

IMPORTANT SAFETY NOTICE

The installation of this kit does not alter the Gross Vehicle Weight Rating (GVWR) or payload of the vehicle. Check your vehicle's owner's manual and do not exceed the maximum load listed for your vehicle.

Gross Vehicle Weight Rating: The maximum allowable weight of the fully loaded vehicle (including passengers and cargo). This number — along with other weight limits, as well as tire, rim size and inflation pressure data — is shown on the vehicle's Safety Compliance Certification Label.

Payload: The combined, maximum allowable weight of cargo and passengers that the truck is designed to carry. Payload is GVWR minus the Base Curb Weight.

NOTATION EXPLANATION

Hazard notations appear in various locations in this publication. Information which is highlighted by one of these notations must be observed to help minimize risk of personal injury or possible improper installation which may render the vehicle unsafe. Notes are used to help emphasize areas of procedural importance and provide helpful suggestions. The following definitions explain the use of these notations as they appear throughout this guide.

DANGER

INDICATES IMMEDIATE HAZARDS WHICH WILL RESULT IN SEVERE PERSONAL INJURY OR DEATH.

WARNING

INDICATES HAZARDS OR UNSAFE PRACTICES WHICH COULD RESULT IN SEVERE PERSONAL INJURY OR DEATH.

CAUTION

INDICATES HAZARDS OR UNSAFE PRACTICES WHICH COULD RESULT IN DAMAGE TO THE MACHINE OR MINOR PERSONAL INJURY.

NOTE

Indicates a procedure, practice or hint which is important to highlight.

Installation Diagram

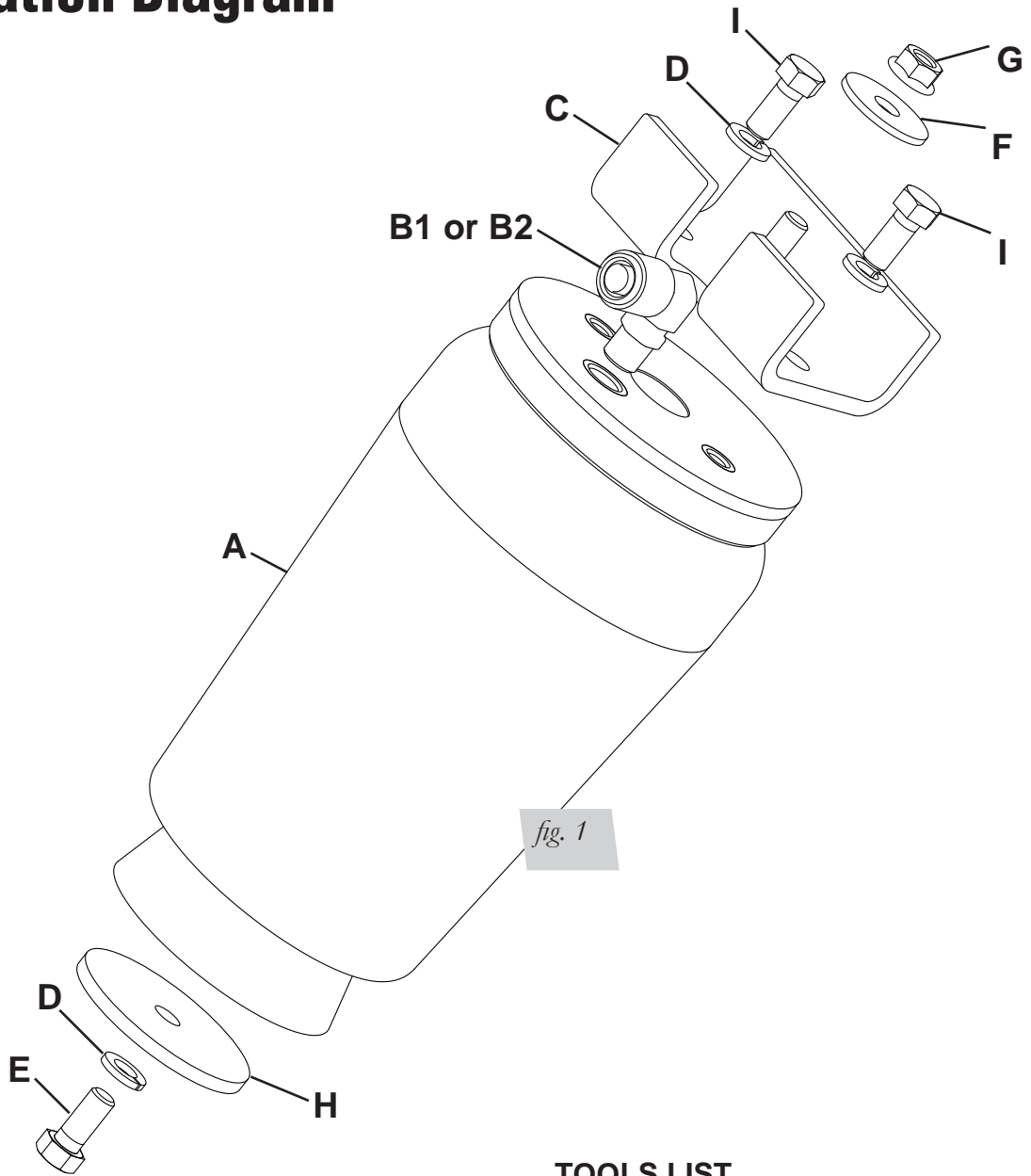

HARDWARE LIST

Item	Part #	Description	Qty
A	58130	Tapered sleeve	2
B1	21846	Fitting - 3/8NPT X 1/4PTC, Elbow	2
B2	21867	Fitting - 3/8NPT X 3/8PTC, Elbow	2
C	07245	Upper bracket	2
D	18427	3/8" Lock washer.....	6
E	17187	3/8"-16 x 7/8" Bolt	2
F	18447	3/8" Flat washer	2
G	18422	3/8" Flange nut.....	2
H	10956	2.75" Flat Washer	2
I	17203	3/8"-24 x 7/8" Bolt	4

TOOLS LIST

Description.....	Qty
Jack	1
Jack stands or hoist.....	2
1/2" Drive ratchet	1
17mm Socket.....	1
12mm Wrench	1
14mm Wrench	1
19mm Wrench & socket	1
3/4" Socket	1
7/16" Socket & end wrench	1
Straight flathead screwdriver	1
Torque wrench.....	1
1/2" Socket & wrench	1



Missing or damaged parts? Call Air Lift customer service at (800) 248-0892 for a replacement part.

Installing the Air Lift Performance Kit

GETTING STARTED

1. Raise the vehicle and support the frame with jack stands.

NOTE

It will be necessary to raise the vehicle high enough to remove the coil springs.

2. Remove the rear wheels.
3. Disconnect the lower shock mount and lower the suspension down low enough to remove the two coil springs.

CAUTION

DO NOT STRETCH THE BRAKE LINES DURING THIS PROCESS. IF NEEDED, DISCONNECT THE BRACKETS HOLDING THE BRAKE LINES.

4. Remove the coil springs. Leave the suspension down for installing the air springs.

ASSEMBLING THE AIR SPRINGS

1. Install a 90° swivel air fitting (B1 or B2); tighten finger tight plus 1½ turns. Do not overtighten.
2. Attach the upper bracket (C) to the air spring using two 3/8" bolts (E) and lock washers (D) and tighten securely.

INSTALLING THE AIR SPRINGS

1. With the suspension still hanging from the coil spring removal, set the air springs in place onto the upper spring seat by inserting the stud on the top bracket into the hole on the upper spring seat with the air fitting pointing to the rear of the vehicle (fig. 2).

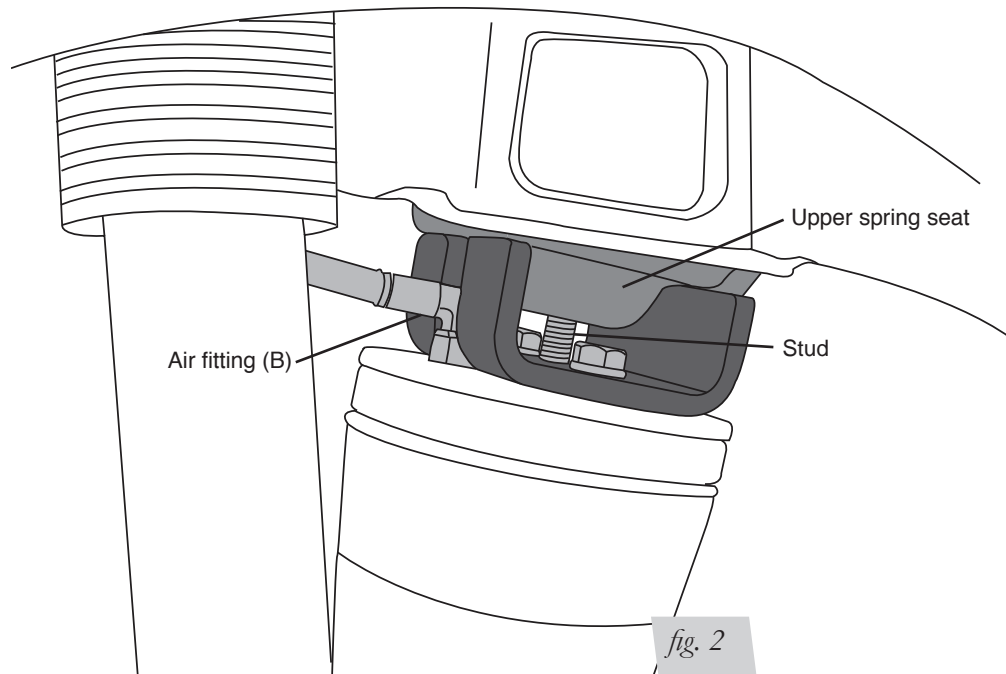

- From the window on the side of the frame, cap the stud with a large flat washer (F) and a 3/8" flange nut (G) (fig. 3). Tighten securely.

NOTE

When tightening the nut, move around the bracket/spring assembly to center the flat washer in the pocket.

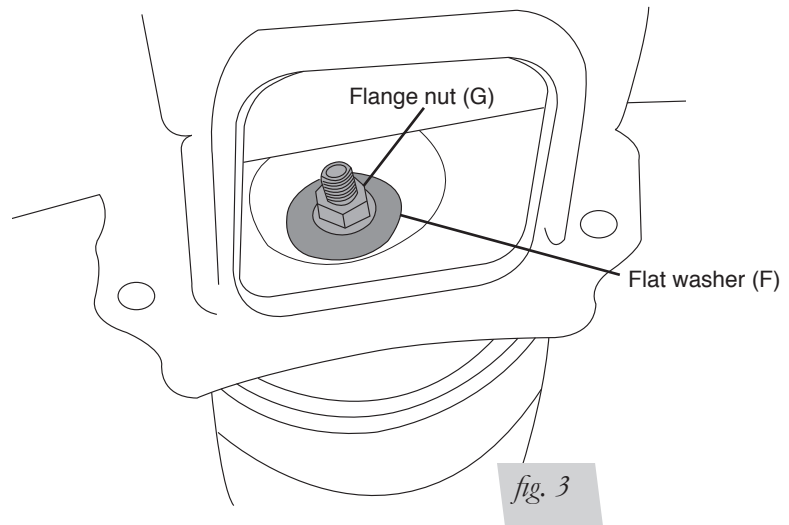

- Repeat for the other side.
- Raise the axle/cross member up far enough to come in contact with the piston on the lower air spring (fig. 4). Make sure the lower piston on the air spring indexes properly into the lower spring pocket hole.
- Cap with the 3/8" large flat washer (H), lock washer (D) and bolt (E) (fig. 4).

CAUTION

TORQUE TO 5 FT/LBS ONLY; USE A TORQUE WRENCH. IF TORQUED MORE THAN 5 FT/LBS, THE INSERT WILL PULL OUT OF THE LOWER PISTON WHICH MAY CAUSE THE PISTON TO COME OUT FROM ITS MOUNTING LOCATION CAUSING EVENTUAL FAILURE.

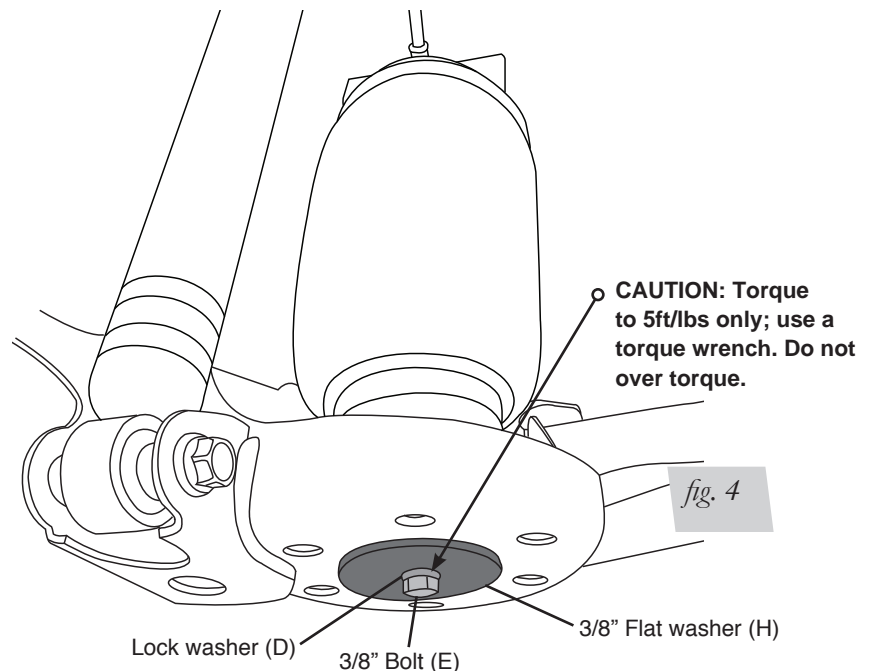

6. Raise the suspension back up and attach the shocks. Reinstall the tires.
7. Finished installation is shown below (fig. 5).

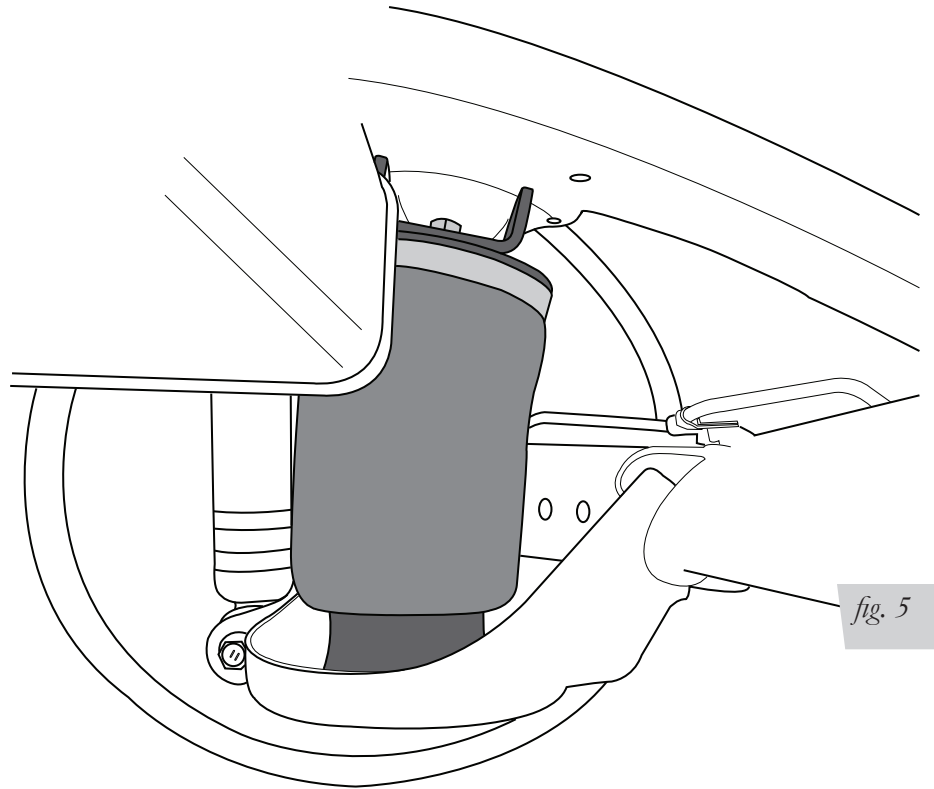

Before Operating

1. The struts for this vehicle come with a nine-position dampening dial for added adjustability (fig. 6). Before driving your vehicle, set the new struts to their highest setting by turning the black dial on the shaft of the strut as far as it will go to the right (position 9).

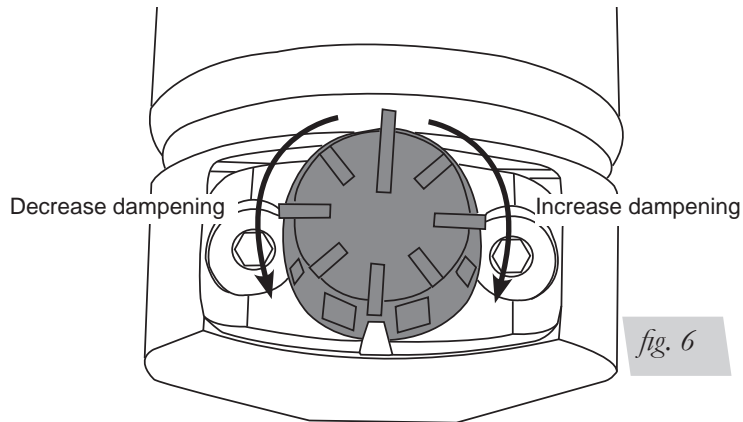

fig. 6

2. Next, completely deflate and reinflate the air bags 2-3 times to evenly distribute the air that may have shifted during shipping. For normal ride performance and the most versatility, LifeSTYLE recommends setting the strut dial to position 3.
3. Inflate and deflate the system (do not exceed 100 PSI) to check for clearance or binding issues. With the air springs deflated, check clearances on everything so as not to pinch brake lines, vent tubes, etc. Clear lines if necessary.
4. Tighten and visually inspect all hardware after 100 miles.
5. Air Lift part #27741 or #27630, High Performance 4 Path Air Management System, is highly recommended for this product.
6. Please continue by reading the Maintenance and Servicing section (page 8).

INSTALLATION CHECKLIST

- Have all bolts been tightened?
- Is there clearance around all steering links and the air spring?
- Has the system been checked for leaks?
- Have all hoses been routed correctly, away from heat sources and secured in a way so they do not chafe on anything?
- Is a copy of the installation instructions in the vehicle for the customer?
- Has the vehicle been properly aligned?

Technician's Signature _____

Date _____

Maintenance and Servicing

1. Attach the air line as instructed in the manual included with your air management system (#27741 or #27630). To purchase an air management system, call Air Lift customer service at (800) 248-0892.

CAUTION

AIR LINES MUST BE ROUTED A MINIMUM OF 3 INCHES AWAY FROM ANY HEAT SOURCE.

2. Inflate and deflate system to check for clearance or binding issues.
3. Struts come with a nine-position dampening dial for added adjustability. Turning the dial clockwise increases dampening.
4. After installation, align the front end of the vehicle.
5. Tighten and visually inspect all hardware after 100 miles.

Minimum Air Pressure	Maximum Air Pressure
10 PSI	100 PSI
FAILURE TO MAINTAIN CORRECT MINIMUM PRESSURE (OR PRESSURE PROPORTIONAL TO LOAD), BOTTOMING OUT, OVER-EXTENSION, OR RUBBING AGAINST ANOTHER COMPONENT WILL VOID THE WARRANTY.	

MAINTAINING AND OPERATING

1. Always maintain ride height. Increase or decrease pressure from the system as necessary to attain ride height for optimal ride and handling. Never inflate the air spring beyond 150 PSI.

CAUTION

FOR YOUR SAFETY AND TO PREVENT DAMAGE TO YOUR VEHICLE, DO NOT EXCEED MAXIMUM GROSS VEHICLE WEIGHT RATING (GVWR), AS INDICATED BY THE VEHICLE MANUFACTURER. CHECK YOUR VEHICLE'S OWNERS MANUAL AND DO NOT EXCEED THE MAXIMUM LOAD LISTED FOR YOUR VEHICLE.

3. Should it become necessary to raise the vehicle by the frame or do any service work, make sure the system is at minimum pressure (10 PSI) for safety and to reduce the tension on the suspension and brake components.

Replacement Information

If you need replacement parts, contact the local dealer or call Air Lift customer service at (800) 248-0892. Most parts are immediately available and can be shipped the same day.

Contact Air Lift Company customer service at (800) 248-0892 first if:

- Parts are missing from the kit.
- Need technical assistance on installation or operation.
- Broken or defective parts in the kit.
- Wrong parts in the kit.
- Have a warranty claim or question.

Contact the retailer where the kit was purchased:

- If it is necessary to return or exchange the kit for any reason.
- If there is a problem with shipping if shipped from the retailer.
- If there is a problem with the price.

Warranty and Returns Policy

Air Lift Company/LifeSTYLE warrants the LifeSTYLE line of products to the original purchaser against manufacturing defects one year from the date of purchase when used on cars and trucks as specified under normal operating conditions. The warranty does not apply to products that have been improperly applied, improperly installed, or which have not been maintained in accordance with installation instructions furnished with all products. The consumer will be responsible for removing (labor charges) the defective product from the vehicle and returning it, transportation costs prepaid, to the dealer from which it was purchased or to Air Lift Company for verification.

Air Lift will repair or replace, at its option, defective products or components. A minimum \$10.00 shipping and handling charge will apply to all warranty claims. Before returning any defective product, you must call Air Lift at (800) 248-0892 in the U.S. and Canada (elsewhere, (517) 322-2144) for a Returned Materials Authorization (RMA) number. Returns to Air Lift can be sent to: Air Lift Company • 2727 Snow Road • Lansing, MI • 48917.

Product failures resulting from abnormal use or misuse are excluded from this warranty. The loss of use of the product, loss of time, inconvenience, commercial loss or consequential damages is not covered. The consumer is responsible for installation/reinstallation (labor charges) of the product. Air Lift Company reserves the right to change the design of any product without assuming any obligation to modify any product previously manufactured.

This warranty gives you specific legal rights and you may also have other rights that may vary from state-to-state. Some states do not allow limitations on how long an implied warranty lasts or allow the exclusion or limitation of incidental or consequential damages. The above limitation or exclusion may not apply to you. There are no warranties, expressed or implied including any implied warranties of merchantability and fitness, which extend beyond this warranty period. There are no warranties that extend beyond the description on the face hereof. Seller disclaims the implied warranty of merchantability. (Dated proof of purchase required.)

Contact Information

If you have any questions, comments or need technical assistance, contact our customer service department by calling (800) 248-0892, Monday through Friday, 8 a.m. to 7p.m. Eastern Time. For calls from outside the USA or Canada, our local number is (517) 322-2144.

For inquiries by mail, our address is PO Box 80167, Lansing, MI 48908-0167. Our shipping address for returns is 2727 Snow Road, Lansing, MI 48917.

You may also contact us anytime by e-mail at sales@airliftcompany.com or on the web at www.airliftcompany.com.

Need Help?

Contact our customer service department by calling (800) 248-0892, Monday through Friday, 8 a.m. to 7 p.m. Eastern Time. For calls from outside the USA or Canada, our local number is (517) 322-2144.

**Register your warranty online at
www.airliftcompany.com/warranty**



Thank you for purchasing Air Lift products — the professional installer's choice!

Air Lift Company • 2727 Snow Road • Lansing, MI 48917 or PO Box 80167 • Lansing, MI 48908-0167
Toll Free (800) 248-0892 • Local (517) 322-2144 • Fax (517) 322-0240 • www.airliftcompany.com

Printed in
the USA