

# Airaid

## INSTALLATION INSTRUCTIONS

404-311 704-506 Airaid Oiled Media Filter

2020-24 FORD F250 / F350

6.7L TURBO DIESEL

**NOT LEGAL FOR SALE OR USE ON ANY POLLUTION CONTROLLED MOTOR VEHICLE IN CALIFORNIA OR STATES ADOPTING CALIFORNIA EMISSION PROCEDURES.**

See Airaid.com for CARB status on each part for a specific vehicle

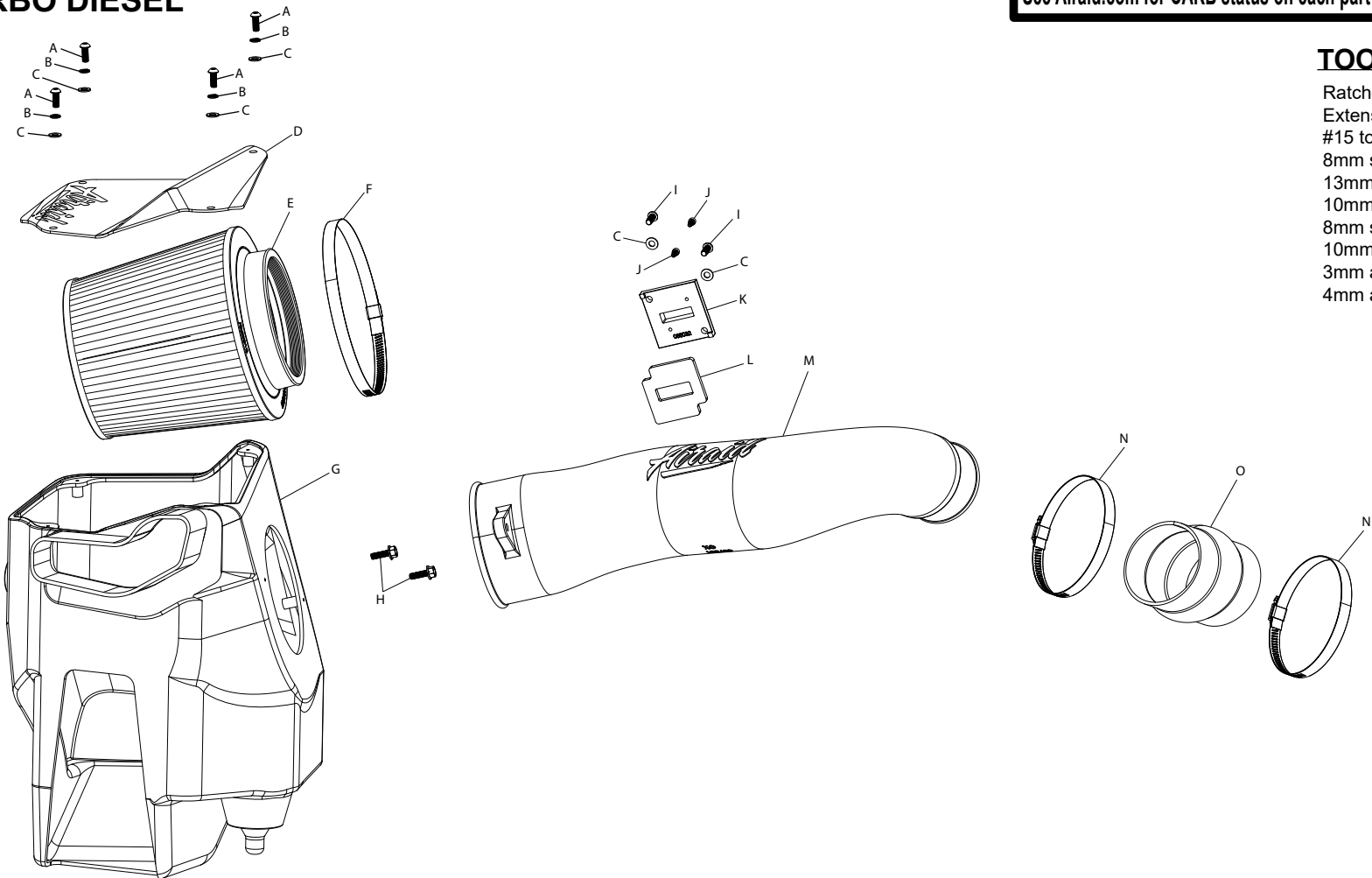

### TOOLS NEEDED:

- Ratchet
- Extension
- #15 torx
- 8mm socket
- 13mm socket
- 10mm socket
- 8mm socket
- 10mm wrench
- 3mm allen key
- 4mm allen key

### COMPONENT IDENTIFICATION

Description	Qty.	Part #	Description	Qty.	Part #	Description	Qty.	Part #
A BOLT; M6-1 X 12MM, BTNHD	4	07794	F HOSE CLAMP; #88	1	KITHS88	K ADAPTOR; MAF SENSOR	1	088032
B WASHER; M6 SPLIT LOCK	4	1-3025	G AIRBOX; (OW)	1	087502	L GASKET; 3/16"PORON	1	09069
C WASHER; 6MM FLAT	6	08269	H BOLT; M6-1 X 20, HEX/FLANGE	2	1-2038	M TUBE; (OX)	1	087501
D LID; CLEAR	1	088082	I BOLT; M6 X 1 X 16MM, BTNHD	2	07730	N HOSE CLAMP; #72	2	08671
E AIR FILTER	1	704-506	J BOLT; M4-.7 X 8MM, ALNHD	2	07733	O HOSE; HUMP 4.5"ID X 3"L	1	08695

Full color instructions can be viewed on our web site at Airaid.com. If you need any assistance please call 1-800-498-6951 to speak with a representative in our Customer Service Center before returning the product.

### TO START:

1. Turn off the ignition and disconnect the negative battery cable.

**NOTE: Disconnecting the negative battery cable erases pre-programmed electronic memories. Write down all memory settings before disconnecting the negative battery cable. Some radios will require an anti-theft code to be entered after the battery is reconnected. The anti-theft code is typically supplied with your owner's manual. In the event your vehicles anti-theft code cannot be recovered, contact an authorized dealership to obtain your vehicles anti-theft code.**



2. Disconnect the mass air sensor electrical connection and unhook the wiring harness from the air filter housing.



3. Loosen the hose clamp that secures the factory intake tube to the turbo inlet pipe.



4. Release the three clips that secure the air filter housing lid and then remove the lid, intake tube and air filter from the vehicle.



5. Remove the pin that secures the fresh air intake duct.



6. Remove the bolt securing the air filter housing and then remove the housing from the vehicle.



## Continued...



7. Remove the two bolts securing the air filter housing bracket to the inner fender and then remove the bracket from the vehicle.



8. Install the AIRAID filter housing and secure with the factory bolt removed in step #6.



9. Install the gasket onto mass air sensor adapter and then remove the mass air sensor from the factory filter housing and install it into the adapter using the provided hardware.

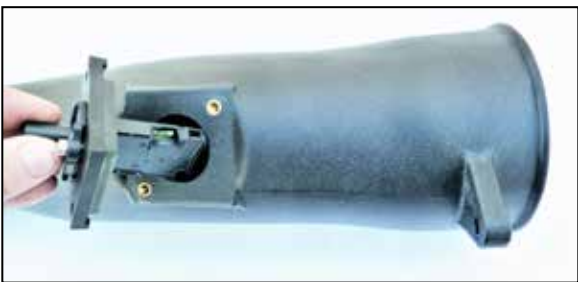

10. Install the mass sensor assembly into the AIRAID intake tube, be sure to install the sensor in the correct position so the opening of the sensor is pointer towards the filter end of the intake tube.



11. Set the AIRAID air filter into the filter housing.

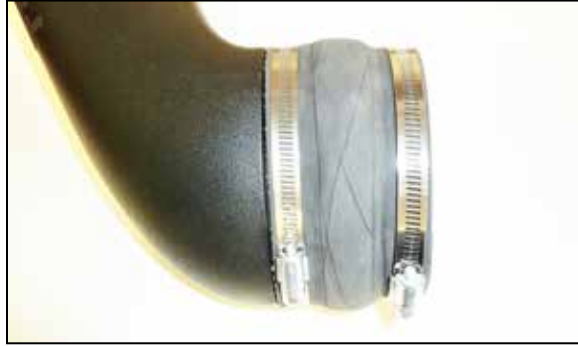

12. Install the provided hump coupler onto the intake tube with the hose clamps as shown.



13. Install the intake tube assembly into the air filter housing and secure with the hardware provided. Align the coupler with the turbo inlet and secure with the provided hose clamps.



14. Install the air filter onto the intake tube and secure with the provided hose clamp.



15. Reconnect the mass air sensor electrical connection.



16. Install the AIRAID cover onto the air filter housing and secure with the provided hardware.



### 17. Double check your work!

Make sure there is no foreign material in the intake path. Make sure all clamps, hoses, bolts, and screws are tight. Double check the hood clearance! **Reconnect the negative battery cable!**

Thank you for purchasing the Airaid Intake System. Contact Airaid @ (800) 498-6951 8:00 AM - 5:00 PM MST weekdays for questions regarding fit or instructions that are not clear to you. Your Airaid Intake System was carefully inspected and packaged. Check that no parts are missing, or were damaged during shipping. If any parts are missing, contact Airaid. The air filter element is protected from direct exposure to water and debris; care should be taken not to drive through deep water. **WATER INGESTION IS THE DRIVERS RESPONSIBILITY!** The air filter is reusable and should be cleaned periodically.

For your Oiled media filter we offer the Airaid Tune Up Kit!



P/N 790-551 Aerosol Spray  
P/N 790-550 Squeeze Spray



**NOT LEGAL FOR SALE OR USE ON ANY POLLUTION CONTROLLED MOTOR VEHICLE IN CALIFORNIA OR STATES ADOPTING CALIFORNIA EMISSION PROCEDURES.**

See Airaid.com for CARB status on each part for a specific vehicle

## SynthaMax

Synthamax Air Filters **do not** require oil. Service air filter as needed by cleaning with common non-petroleum all-purpose household cleaner and water. Simple Green®, Formula 409® or equivalent works great. Apply cleaner to outside of air filter and allow to soak. Then flush filter clean from the inside out with a garden hose and repeat steps if necessary. Do not apply high pressure water or air to clean filter. Allow filter to air dry and reinstall.