

Airaid

INSTALLATION INSTRUCTIONS

404-362 704-462 Airaid Oiled Media Filter

405-362 705-462 SynthaMax Dry Media Filter

2019-23 FORD Ranger

L4-2.3L Turbo

NOT LEGAL FOR SALE OR USE ON ANY POLLUTION CONTROLLED MOTOR VEHICLE IN CALIFORNIA OR STATES ADOPTING CALIFORNIA EMISSION PROCEDURES.

See Airaid.com for CARB status on each part for a specific vehicle

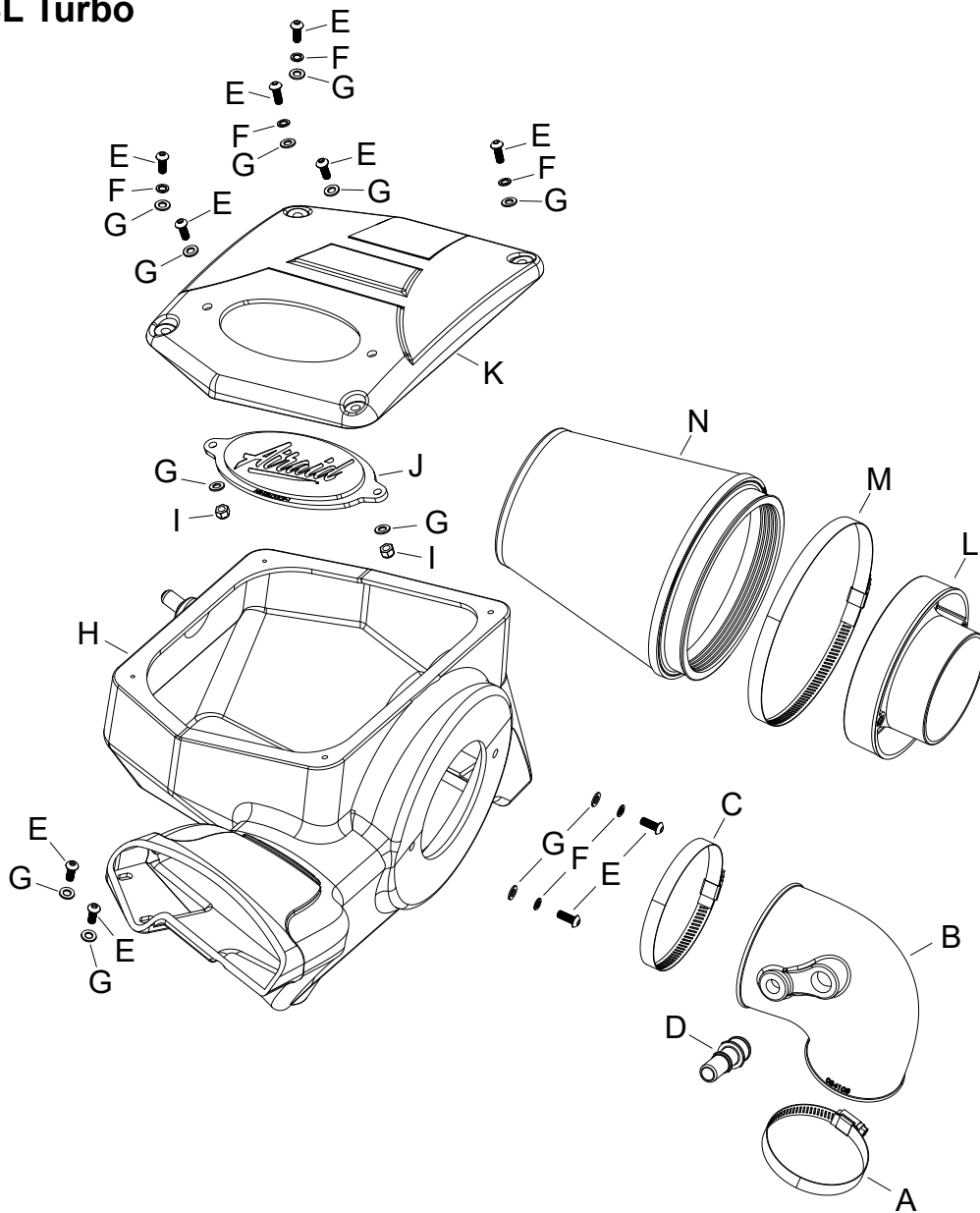

TOOLS NEEDED:

ratchet
extension
5/16" socket
7/16" socket
t30 torx
4mm allen key
flat blade screw driver

COMPONENT IDENTIFICATION

	Description	Qty.	Part #
A	HOSE CLAMP #48	1	08601
B	HOSE; 3"ID TO 4"ID X 78	1	084108
C	HOSE CLAMP #64 STAINLESS	1	08645
D	FITTING; 217 ALUMINUM	1	KITFITTING15
E	BOLT; M6 X 1 X 16MM BTNHD	10	07730
F	WASHER, M6 SPLIT LOCK ZINC	6	1-3025
G	WASHER; 6MM FLAT	12	08269
H	AIRBOX; (NE)	1	087447
I	NUT; 6MM NYLOCK, HEXHD	2	07512
J	PLATE; AIRAID LOGO - CLEAR	1	KITLOGOP-1
K	LID; (NG)	1	087448
L	ADAPTOR; #454	1	27300
M	CLAMP; #104, 9/16", SS	1	KITHS104
N	AIR FILTER	1	704/705-462

Full color instructions can be viewed on our web site at Airaid.com. If you need any assistance please call 1-800-498-6951 to speak with a representative in our Customer Service Center before returning the product.

TO START:

1. Turn off the ignition and disconnect the negative battery cable.

NOTE: Disconnecting the negative battery cable erases pre-programmed electronic memories. Write down all memory settings before disconnecting the negative battery cable. Some radios will require an anti-theft code to be entered after the battery is reconnected. The anti-theft code is typically supplied with your owner's manual. In the event your vehicles anti-theft code cannot be recovered, contact an authorized dealership to obtain your vehicles anti-theft code.



2. Disconnect the inlet air temperature sensor electrical connection and disconnect the crank case vent line from the factory intake tube.



3. Remove the two bolts that secure the factory fresh air intake duct and then remove the duct from the vehicle.



4. Remove the front air filter housing mounting bolt and unhook the wiring harness from the housing.



5. Remove the rear air filter housing mounting bolt and loosen the hose clamp that secures the intake hose to the housing.



6. Remove the air filter housing from the vehicle. **NOTE: AIRAID recommends that customers do not discard factory air intake.**

Continued...



7. Loosen the hose clamp that secures the intake hose to the plenum and then remove the hose from the vehicle.



8. Remove the factory air filter housing mounting post and install it onto the AIRAID® air filter housing as shown.



9. Install the AIRAID® air filter housing assembly and secure the air filter housing with the factory hardware and the fresh air duct with the hardware provided.



10. Install the filter adapter into the AIRAID® air filter and secure with the provided hose clamp.



11. Install the air filter assembly into the housing and secure with the provided hardware.



12. Remove the inlet air temperature sensor from the factory housing and remove the O-Ring from the sensor, Install the sensor into the AIRAID® coupler. Install the provided quick disconnect fitting into the AIRAID® coupler as shown.



13. Install the coupler onto the intake plenum and connect to the filter adapter, adjust for best fit and secure with the provided hose clamps.



14. Reconnect the inlet air temperature sensor electrical connection and connect the crank case vent line to the quick connect fitting as shown.



15. Install the AIRAID® window into the lid and secure with the provided hardware.



16. Install the lid onto the filter housing and secure with the provided hardware.



17. Double check your work!

Make sure there is no foreign material in the intake path. Make sure all clamps, hoses, bolts, and screws are tight. Double check the hood clearance! **Reconnect the negative battery cable!**

Thank you for purchasing the Airaid Intake System. Contact Airaid @ (800) 498-6951 8:00 AM - 5:00 PM MST weekdays for questions regarding fit or instructions that are not clear to you. Your Airaid Intake System was carefully inspected and packaged. Check that no parts are missing, or were damaged during shipping. If any parts are missing, contact Airaid. The air filter element is protected from direct exposure to water and debris; care should be taken not to drive through deep water. **WATER INGESTION IS THE DRIVERS RESPONSIBILITY!** The air filter is reusable and should be cleaned periodically.

For your Oiled media filter we offer the Airaid Tune Up Kit!



P/N 790-551 Aerosol Spray
P/N 790-550 Squeeze Spray



NOT LEGAL FOR SALE OR USE ON ANY POLLUTION CONTROLLED MOTOR VEHICLE IN CALIFORNIA OR STATES ADOPTING CALIFORNIA EMISSION PROCEDURES.

See Airaid.com for CARB status on each part for a specific vehicle

SynthaMax

Synthamax Air Filters do not require oil. Service air filter as needed by cleaning with common non-petroleum all-purpose household cleaner and water. Simple Green®, Formula 409® or equivalent works great. Apply cleaner to outside of air filter and allow to soak. Then flush filter clean from the inside out with a garden hose and repeat steps if necessary. Do not apply high pressure water or air to clean filter. Allow filter to air dry and reinstall.