

INSTALLATION INSTRUCTIONS

FORD F-150 2WD & 4WD RETAINS FACTORY TOW HOOKS PART #P3063

PARTS LIST:

1	Grille Guard	2	10-1.5mm Nylon Lock Nuts
1	Driver/Left Frame Mounting Bracket	4	12mm Plastic Washers
1	Passenger/Right Frame Mounting Bracket	2	12mm Double Nut Plates
1	Driver/Left Top Bracket	2	12mm x 35mm Bolt Plates
1	Passenger/Right Top Bracket	10	12-1.75mm x 35mm Hex Bolts
1	Driver/Left Top Support Bracket	2	12mm ID x 42mm x 42mm x 5.75mm Square Washers
1	Passenger/Right Top Support Bracket	14	12mm x 32mm OD x 3mm Flat Washers
1	Driver/Left Top Support Brace	12	12mm Lock Washers
1	Passenger/Right Top Support Brace	2	12mm Hex Nuts
1	50mm x 75mm x 1.0mm Adhesive Foam Tape	1	Support flange
2	10mm Quick Release Bolts	2	8mm Nut clips
2	10mm Special Pivot Washers	2	8mm hex bolts
4	10mm Plastic Washers	2	8mm Flat washers
4	10mm x 27mm x 3mm Flat Washers	2	8mm Lock washers
		4	M12 - 1.75 Nylon Lock Nuts

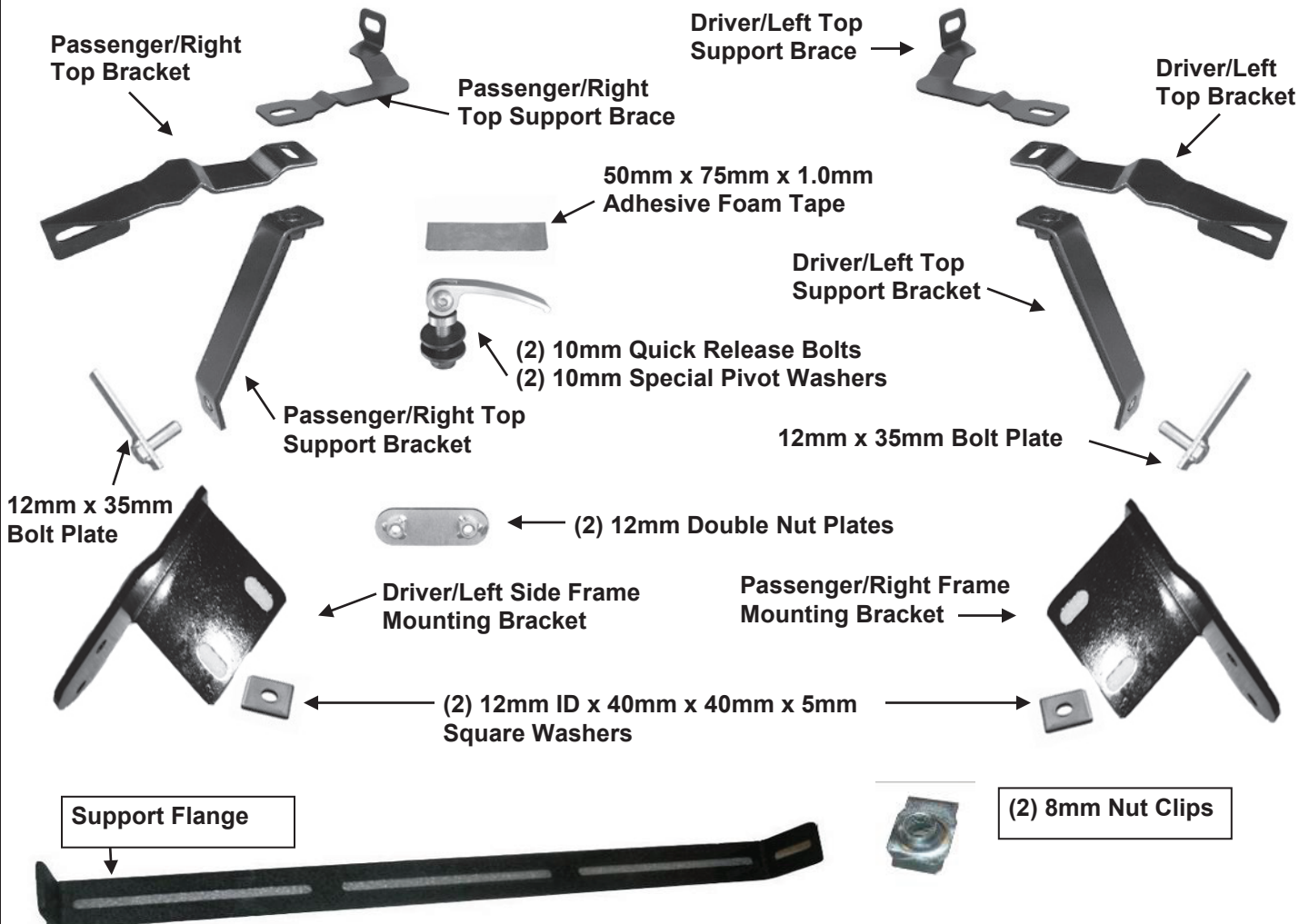

PROCEDURE:

REMOVE CONTENTS FROM BOX. VERIFY ALL PARTS ARE PRESENT. READ INSTRUCTIONS CAREFULLY BEFORE STARTING INSTALLATION. ASSISTANCE IS RECOMMENDED. CUTTING IS REQUIRED ON VEHICLES WITHOUT TOW HOOKS. LICENSE PLATE MUST BE RELOCATED ON VEHICLES EQUIPPED WITH ECOBOOST.

WARNING! This Grille Guard is designed to tilt forward to open the hood for service. The Top Bracket Quick Release Bolts and the upper bolts on the Frame Mounting Brackets will need to be loosened slightly to rotate the Grille Guard. Make sure that all hardware is fully tightened after closing the hood before moving vehicle. **Please read Page 8, "Opening and Closing of Hood,"** before installing the Grille Guard.

NOTE: It may be necessary to remove/relocate the front license plate and license plate bracket. It is not required, but strongly recommended. If local/state law requires a license plate, a license plate relocation kit is available.

1. Start by Selecting your LED light (**Sold Separately**) mounting hardware & brackets, you will need to first attached the hardware to the support flange, (Example of LED light attached Fig 1) **NOTE: if you have your own LED light, LED Manufactures will have similar but different mounting styles or brackets, once you determine you mounting options attach it to the support flange as seen in (Fig1)**
2. With the LED light attached to the support flange select the (2) 8mm nut clips place each nut clip into the slotted holes on either side of the support flange, as seen in **(Fig 2)** with the support flange prepare you will need to lay the grill guard face down to install the support flange **NOTE:** (it is recommended to lay out some of the cardboard your grill guard came in or a blanket to protect the grill guard finish). place the grill guard face down with this done place the support flange with the LED attached into the Center flange attach each side of the support flange to the inner brackets inside the center flange of the grill guard with (2) 8mm hex bolts, (2) 8mm flat washers, & (2) 8mm lock washers as seen in **(Fig 3)** Snug but do not tighten at this time.
3. Determine if the vehicle is or is not equipped with factory tow hooks.
Installation on vehicles with Factory Tow Hooks:
 - a. Remove the driver side tow hook, **(Fig 4)**.
 - b. Starting with the driver/Left side Begin your install by removing the factory tow hooks on the vehicle. **(Do not discard as these will be re-attached)**. The tow hooks are located just under the front bumper, and are attached to the lower front of frame rails with two bolts attaching to a nut plate inside the frame rail, **(by removing the front mounting bolt and only loosen the rear bolt you will be able to control the nut plate from moving)** with tow hook removed, place the driver/Left side frame mounting bracket up to the bottom of the frame with the tow hook. Insert the Front factory bolt through the tow hook, and mounting bracket, securing them to nut plate hand tighten. Now remove the rear bolt. so you can slide the mounting bracket and tow hook over, reattach rear bolt threw the tow hook and mounting bracket then back into the nut plate. **(Fig 4A)** shown are bracket & tow hook attached. Snug, but do not tighten hardware at this time. Repeat this step for the Passenger/right side installation

Installation on vehicles without Tow Hooks:

- a. Remove the lower plastic portion of the bumper and air dam, **(Fig 7)**.
- b. Insert (1) 12mm Double Nut Plate through the opening in the front end of the driver side of the frame, **(Figs 8A & 8B)**. Line up the threaded holes with the holes in the bottom of the frame.
- c. Insert (1) 12mm x 35mm Hex Bolt, (1) 12mm Lock Washer and (1) 12mm Square Spacer into the rear hole in the bottom of the frame and up into the Double Nut Plate, **(Figs 5A & 5B)**. Leave completely loose. Select the driver side Frame Mounting Bracket. Slide the slotted end of the Bracket under the Hex Bolt and Square Washer, **(Fig 6)**. Insert (1) 12mm x 35mm Hex Bolt, (1) 12mm Lock Washer and (1) 12mm Flat Washer into the empty remaining forward hole in the Bracket and Nut Plate. Snug but do not tighten the hardware at this time.
- d. Repeat **Steps a – c** for passenger side Frame Mounting Bracket installation.
- e. Do not reinstall the plastic lower bumper cover at this time, (See **Steps 14a & 14b**).

4. Open the front hood on the vehicle. Locate the top of the bumper bracket behind the driver side of the front bumper. Locate the open hole in the top outer end of the bumper bracket, **(Fig 9)**. Insert (1)

12mm x 35mm Bolt Plate down and into the gap at the top of the bracket and out through the hole with the threaded end of the Bolt Plate facing to the rear toward the radiator, **(Figs 10A & 10B)**. Slide the lower end of the driver side Top Support Bracket, (end with hole), over the Bolt Plate. Secure the Bracket to the Bolt Plate with (1) 12mm Flat Washer, (1) 12mm Lock Washer and (1) 12mm Hex Nut, **(Fig 11)**. **IMPORTANT:** Do not tighten hardware at this time.

NOTE: Before proceeding, cover the top of the plastic bumper, (driver and passenger sides), with removable tape, (masking tape for example), to protect the bumper during Top Bracket installation, **(Fig 11)**. Next, apply a section of the included Adhesive Backed Foam Tape to the bottom of both Top Brackets to prevent damage to the painted finish on the vehicle, **(Fig 13)**.

5. Select the driver side Top Support Brace, **(Fig 12A)**. Remove the factory hex bolt in the radiator mount. Bolt the Support Brace in place with the factory hex bolt, **(Fig 12B)**. Leave loose at this time.

6. Select the driver side Top Bracket. Insert the Top Bracket between the Support Bracket and the Rear Brace, **(Fig 13)**. Line up the (3) holes and bolt the Brackets together with (1) 12mm x 35mm Hex Bolt, (1) 12mm Lock Washer and (1) 12mm Flat Washer, **(Fig 12B)**. **IMPORTANT:** Do not tighten hardware at this time.

NOTE: It may be necessary to raise or lower the height of the Top Bracket to fit properly between the grille and the top of the bumper. Loosen the 12mm Hex Nut attaching the bottom of the Support Bracket to the Bolt Plate, **(Fig 11)**. Move the Top Bracket up or down as needed to clear the top of the bumper and line up with the Grille Guard before tightening the hardware. Do not fully tighten Top Bracket hardware until after all hardware has been installed and the Grill Guard properly aligned and adjusted.

7. Repeat **Steps 4 – 6** for passenger side Top Bracket, Support Bracket and Top Brace installation.

8. With assistance, place the Grille Guard face down on a clean surface in front of the vehicle, **(Fig14)**. Position the mounting tabs on the Grille Guard up to the outside of the Frame Mounting Brackets.

9. Line up the rear hole in the driver side Frame Mounting Bracket with the hole in the Grille Guard, **(Fig 15)**. Insert (1) 12mm Plastic Washer between the Mounting Bracket and the Grille Guard. Bolt the Grille Guard to the driver side Bracket with (1) 12mm x 35mm Hex Bolt, (2) 12mm Flat Washers, & (1) 12mm Nylon Lock Nut **(Fig 15)**. Snug but do not tighten hardware at this time.

10. Repeat **Step 9** to attach the Grill Guard to the passenger side Bracket.

11. Use the two previously installed Hex Bolts as a hinge. Rotate the Grille Guard up to the vehicle, **(Fig 14)**. Line up the remaining hole in each Bracket with the Grille Guard. Insert a 12mm Plastic Washer between the Mounting Bracket and the Grille Guard on both sides of the vehicle as described in **Step 9**. Bolt the Grille Guard to the Brackets with (2) 12mm x 35mm Hex Bolts, (4) 12mm Flat Washers and (2) 12mm Nylon Lock Nuts. Do not tighten hardware at this time.

12. Next, line up the slotted end of the driver side Top Bracket with the hole in the Grille Guard upright. Insert (1) 10mm Plastic Washer between the Top Bracket and the Grille Guard, **(Fig 16)**. Line up the hole in the Plastic Washer with the hole in the Grille Guard and the slot in the Top Bracket. Insert (1) 10mm Quick Release Bolt, (1) 10mm Special Pivot Washer and (1) 10mm Flat Washer through the upright on the Grille Guard first and on through the Plastic Washer and Top Bracket. Secure the Quick Release Bolt with (1) 10mm Plastic Washer, (to protect the finish on the Top Bracket), (1) 10mm Flat Washer and (1) 10mm Nylon Lock Nut, **(Figs 17A & 17B)**. Do not tighten hardware at this time.

13. Repeat **Step 12** for the passenger side Quick Release installation.

14. With the hood open, push the Grille Guard back until it is vertical. Align, center and adjust the Grille Guard properly and tighten all Mounting Bracket and Support Bracket hardware.

Vehicles without tow hooks:

- a. Once the Frame Brackets are fully tightened to the vehicle, temporarily remove only the Grille Guard. Hold the plastic lower bumper cover up in the approximate position against the bottom Of the bumper and against the Brackets, (If cover was previously removed in **Step 3a**). Mark the Bracket location onto the back of the bumper cover. Cut slots through the cover to clear the Brackets, (**Fig 18**). **IMPORTANT:** For best results, start with a small opening and only trim away material required for Bracket clearance. Once properly trimmed, reinstall plastic bumper cover with the factory hardware.
- b. Reinstall the Grille Guard and tighten all Mounting Bracket and Support Bracket hardware.

15. Release the levers on the Quick Release Bolts, (**Fig 19**), and loosen the top Hex Bolts on the Frame Mounting Bracket. **WARNING!** Do not loosen the bolts all the way. Loosen hardware only enough to move the Grille Guard. Damage to the truck or Grille Guard may occur.

16. Pull the Grille Guard all the way forward, away from the vehicle, (**Fig 20**).

17. Carefully close the hood and check for clearance between the Top Bracket and the factory grille. Adjust the Brackets up or down for fit as necessary. **IMPORTANT:** Always make sure that the hood and grille will clear the Grille Guard before closing the hood.

18. Close the hood. Push the Grille Guard back towards the vehicle until it is vertical, check the alignment again and adjust the Grille Guard as required. Tighten all Mounting Bracket hardware including the Quick Release Bolts, (**Fig 19**).

19. Do periodic inspections to the installation to make sure that all hardware is secure and tight, **For the Led lights wiring please refer to the manufactures installation.**

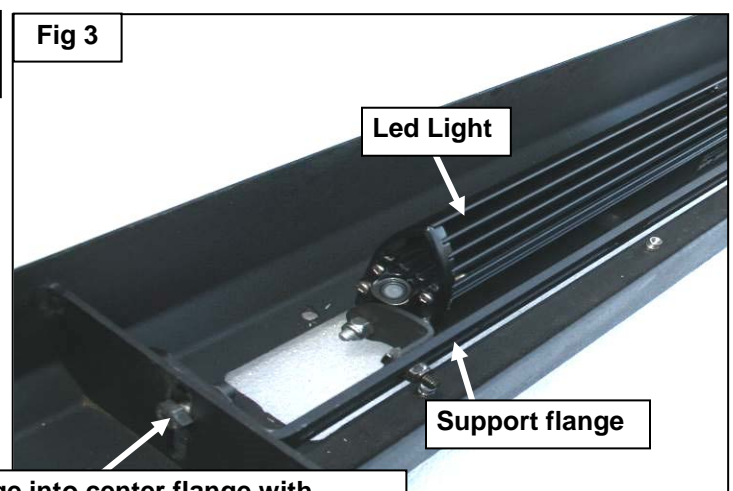
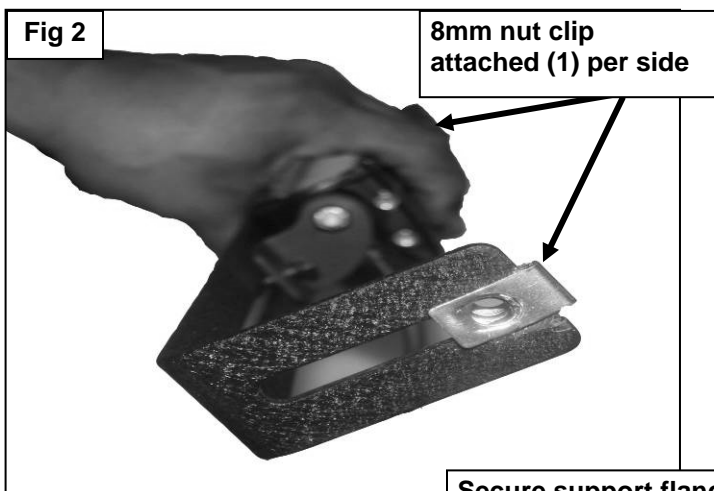
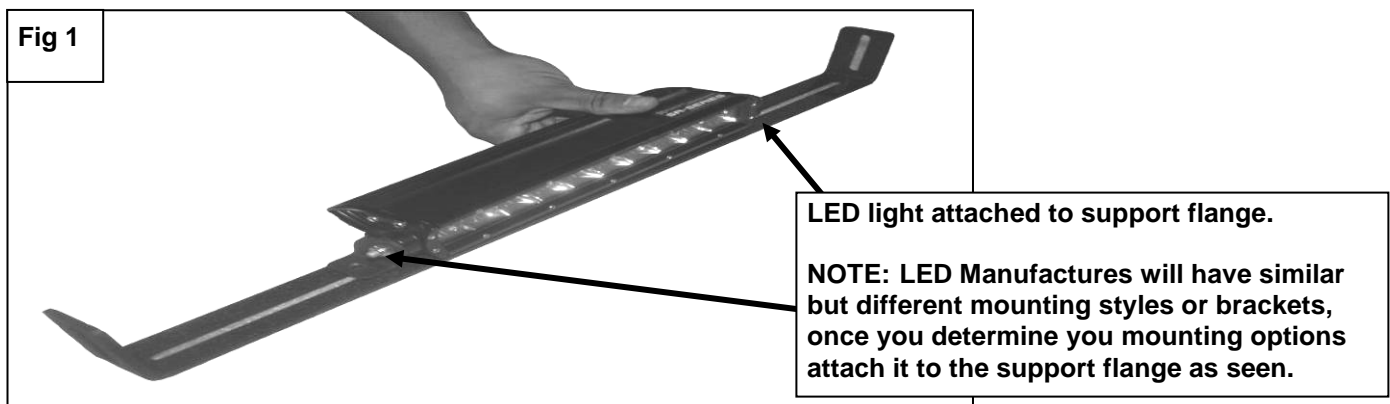

Secure support flange into center flange with
 (1) 8mm Hex head bolt
 (1) 8mm Flat Washers
 (1) 8mm Lock washer
 Per side.

Driver Side Installation Pictured

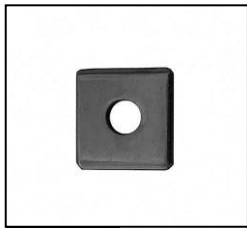
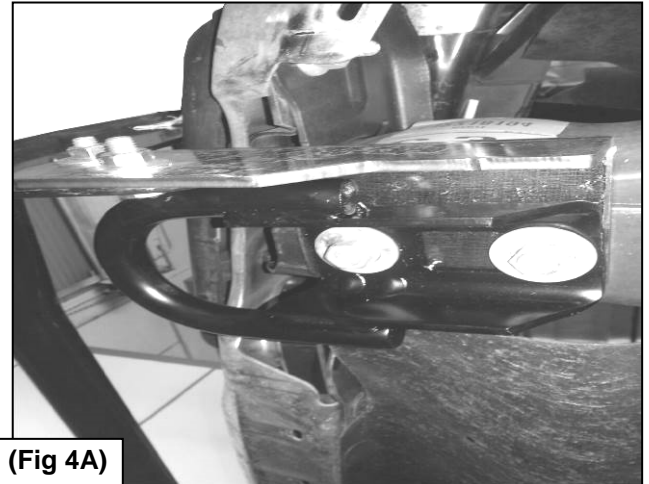
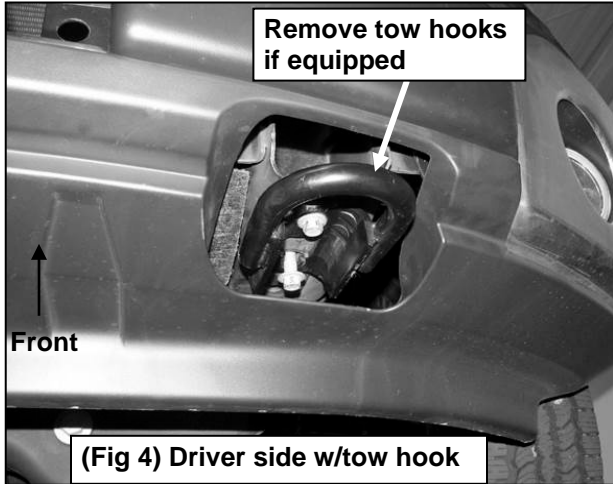

Fig 5A

12mm x 35mm Hex Bolt
12mm Lock Washer
12mm Flat Washer

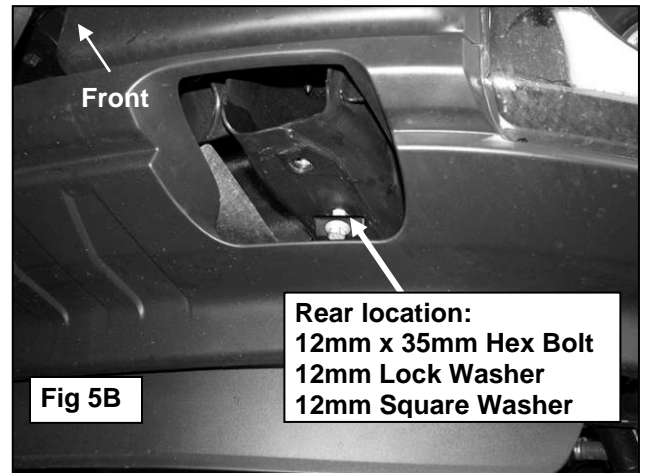
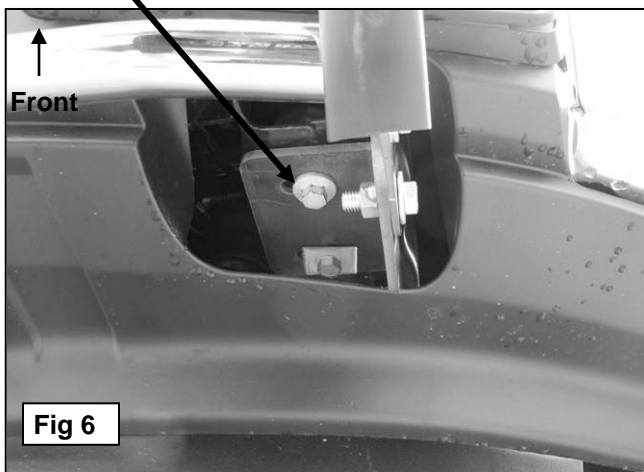
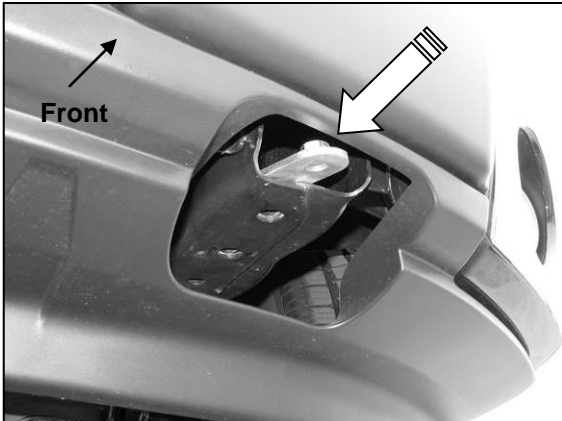

Fig 5B



(Fig 7) Example of lower bumper cover on vehicles without tow hooks

Driver Side Installation Pictured



(Fig 8B) Insert Nut Plate through opening in end of frame (NOTE: Tow hook model pictured for instruction purposes only)

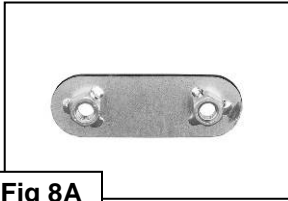
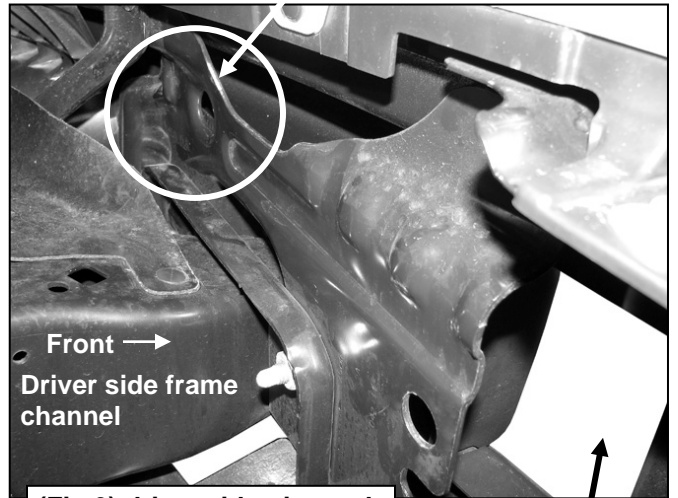

Fig 8A

Insert 12mm Bolt Plate through outermost hole in bumper bracket



(Fig 9) driver side pictured

Opening in center of bumper

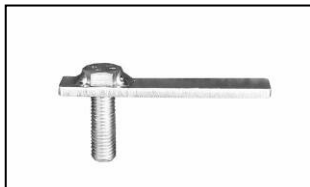

(Fig 10A) 12mm x 35mm Bolt

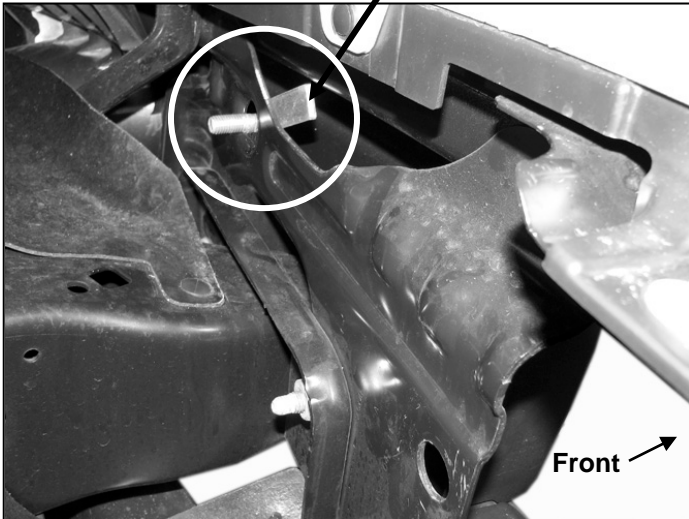

(Fig 10B) Driver side pictured from behind bumper

Cover a section (dotted line) of the top of the bumper with removable tape to prevent damage to finish on bumper

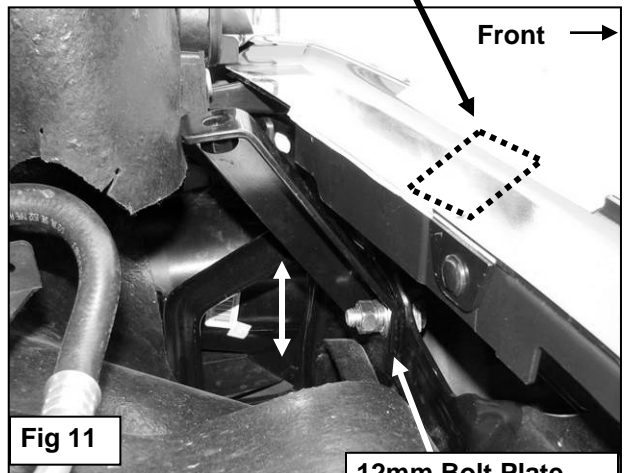
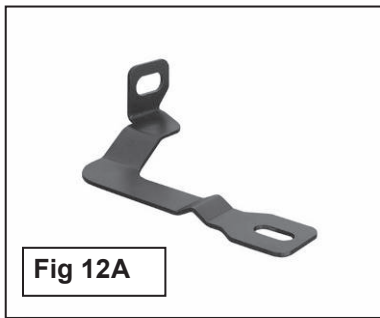

Fig 11

12mm Bolt Plate
12mm Lock Washer
12mm Flat Washer
12mm Hex Nut

Loosen Hex Nut on Bolt Plate (Fig 8) and adjust height of Support Bracket (up or down) as necessary. Do not tighten Hex Nut until final adjustment step.

Driver Side Installation Pictured



Use factory hex bolt

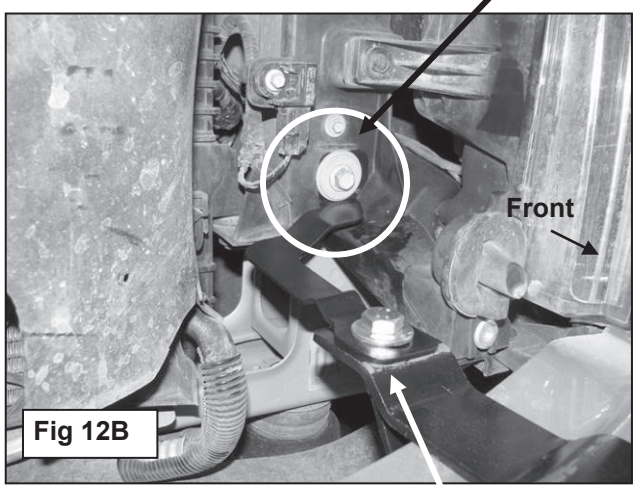

12mm x 35mm Hex Bolt
12mm Lock Washer
12mm Flat Washer

Cover a section (dotted line) of the bottom of the Bracket with Foam Tape to prevent damage to finish on bumper

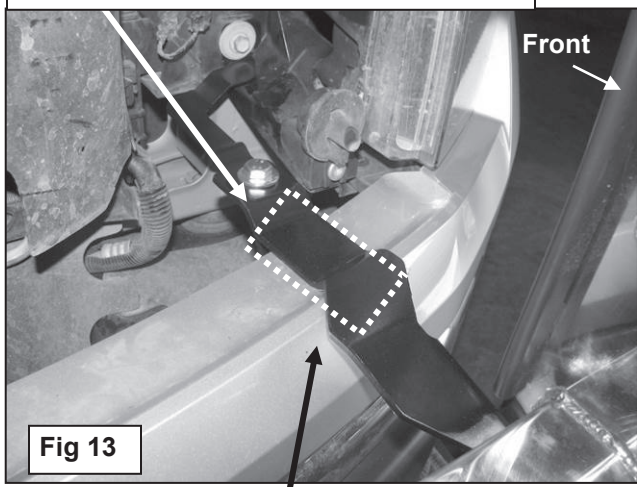

Protect the top of the plastic bumper cover with masking tape to prevent scratches during installation

For easier installation, insert (1) 12mm Hex Bolt, (2) 12mm flat washers on each side and secure with (1) 12mm nylock nut in location shown in Figure 8 to act as a hinge.

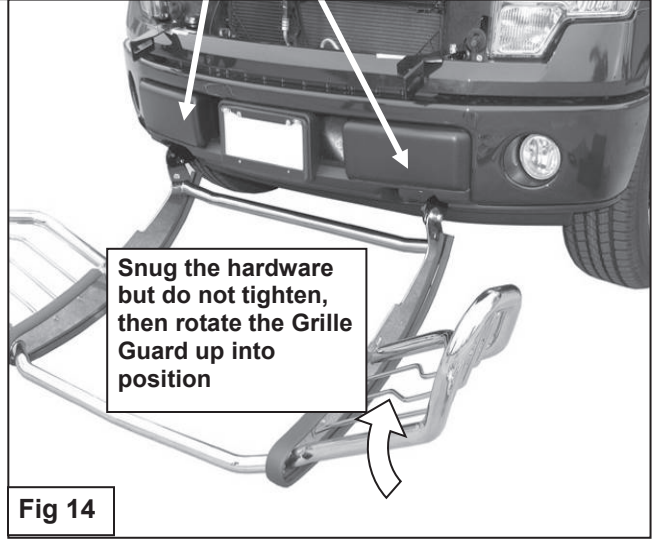

Snug the hardware but do not tighten, then rotate the Grille Guard up into position

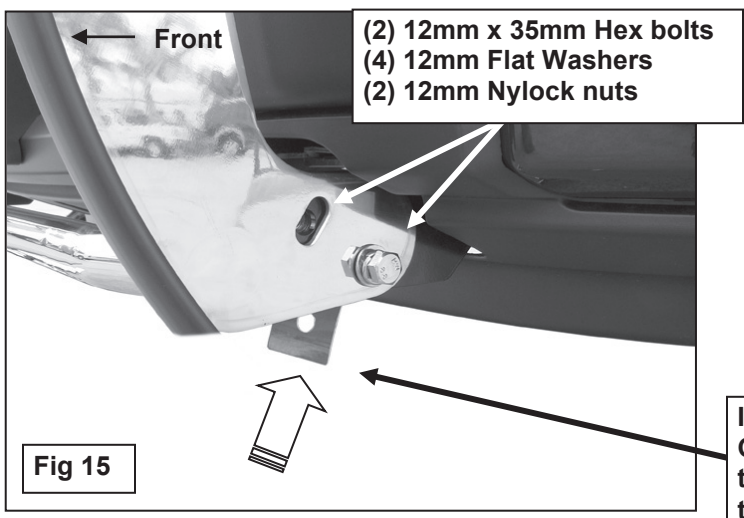

(2) 12mm x 35mm Hex bolts
(4) 12mm Flat Washers
(2) 12mm Nylock nuts

Insert 12mm Plastic Washers between the Grille Guard and the Mounting Bracket. Line up the holes in the Plastic Washers with the mounting holes. Insert the Mounting Bolts through the Plastic Washers

Driver Side Installation Pictured

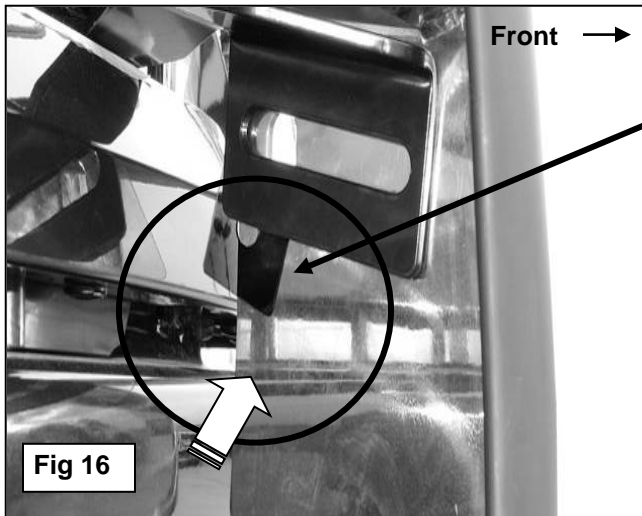

Insert a 10mm Plastic Washer between the Grille Guard and the slotted Top Bracket. Line up the hole in the Plastic Washer with the mounting holes. Insert the Quick Release Bolt through the Plastic Washers

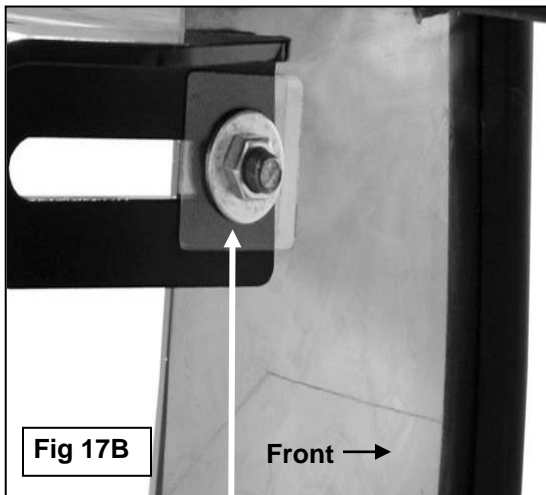
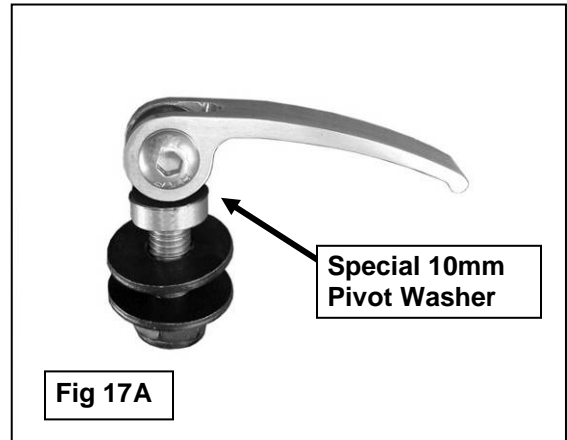

Place a 10mm Plastic Washer between the slotted Top Bracket and the 10mm Flat Washer to protect the finish on the Top Support Bracket. Inside of upright on Grille Guard pictured

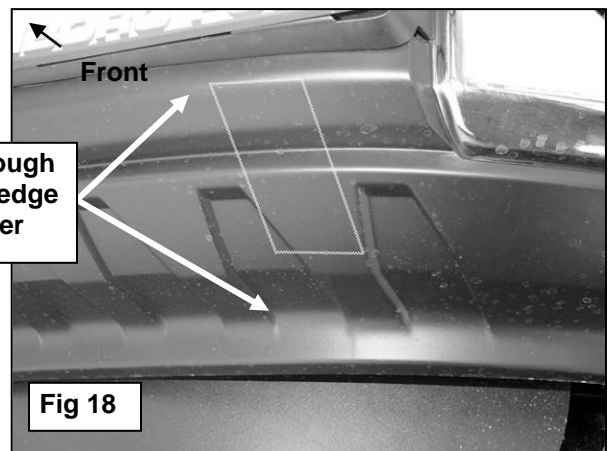

Non tow hook model pictured. Once Grille Guard has been completely installed and lined up properly on the vehicle, tighten only the hardware bolting the Frame Brackets to the frame. Remove the Grille Guard. Hold the plastic lower bumper cover up in the original position against the Brackets. Trace the Frame Bracket locations onto the cover. Cut out the area with sharp knife or hacksaw blade. Cut as little as possible from cover. Do not cut through top or bottom edge. Cut area pictured for example only. Installer responsible for correct modifications

Driver Side Installation Pictured

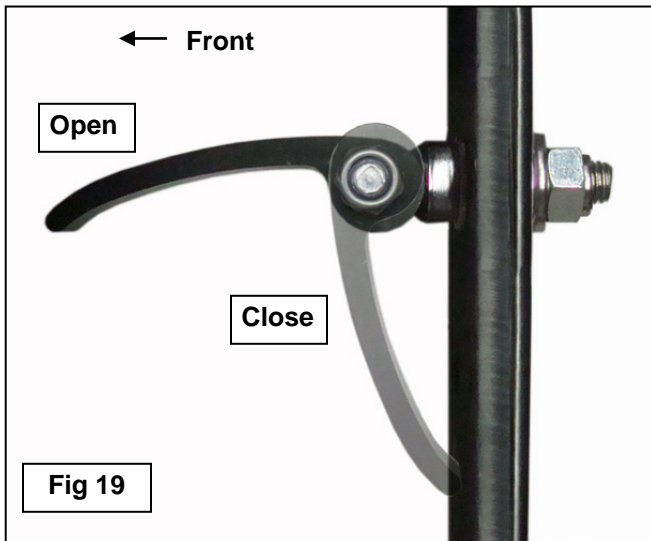

Tighten or loosen the 10mm Nylon Lock Nut to adjust the clamping pressure on the Quick Release Bolt. When properly adjusted, it should require reasonable force (by hand only) to completely close the lever

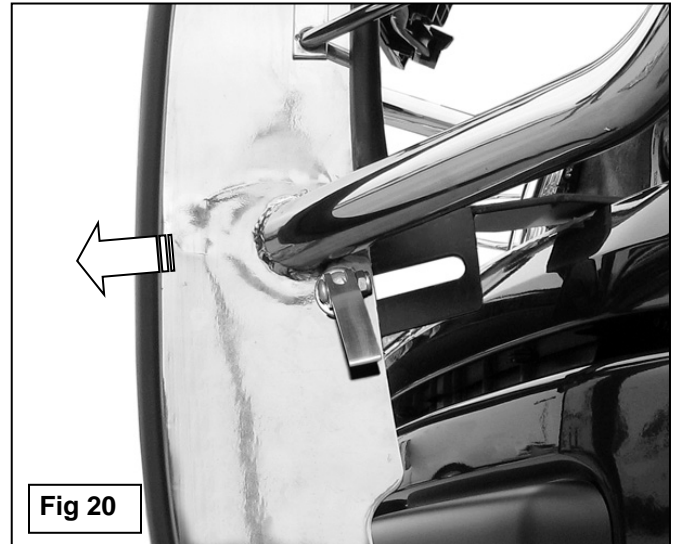

To open the hood, release the lever on the Quick Release Bolts. Try to pull the Grille Guard forward. If necessary, loosen the Hex Bolts securing the Grille Guard to the Mounting Brackets. Only loosen the hardware enough to move the Grille Guard



Opening and closing the hood

1. Lift the levers on the two Quick Release Bolts to release clamping pressure, (**Fig 19**). Try to pull the Grill Guard forward. If necessary, slightly loosen the top hex bolts on the Frame Mounting Brackets to pivot the Grille Guard away from the vehicle. Carefully pull on the Grille Guard until it is fully extended away from the vehicle, (**Fig 20**). **WARNING!** Do not loosen the bolts all the way. Damage to the truck or Grille Guard may occur. Only loosen the bolts enough to move the Grille Guard.
2. Pull the hood release and open the hood.
3. **IMPORTANT:** Before closing the hood, always check to make sure that the Grille Guard hasn't been pushed back to its "closed" position and that it is fully extended away from the vehicle, then close the hood.
4. Once the hood is completely closed, push the Grille Guard back to its closed, upright position and tighten all hardware on the Grille Guard. Push down on the Quick Release lever to tighten, (**Fig 19**). No tools are required to close the Quick Release levers. It will require some effort to open and close by hand when properly adjusted. Loosen or tighten the 10mm Nylon Lock Nut on the Quick Release bolt to adjust the clamping pressure.
5. Do periodic inspections to the installation to make sure that all hardware is secure and tight.

To protect your investment, wax this product after installing. Regular waxing is recommended to add a protective layer over the finish. Do not use any type of polish or wax that may contain abrasives that could damage the finish.