

Any damaged or missing parts?

Parts will be shipped to you directly.

Call 818-365-9000 Mon - Fri 8:30 am - 7:00 pm EST

or email support@bakindustries.com

TOOLS REQUIRED

- Scissors or utility knife
- Isopropyl alcohol
- 1/2" Wrench or socket
- Phillips screwdriver
- 5/8" Drill bit & drill

NOTE: It is important that all areas where the bed cover mounts are clean and free of debris prior to installing.

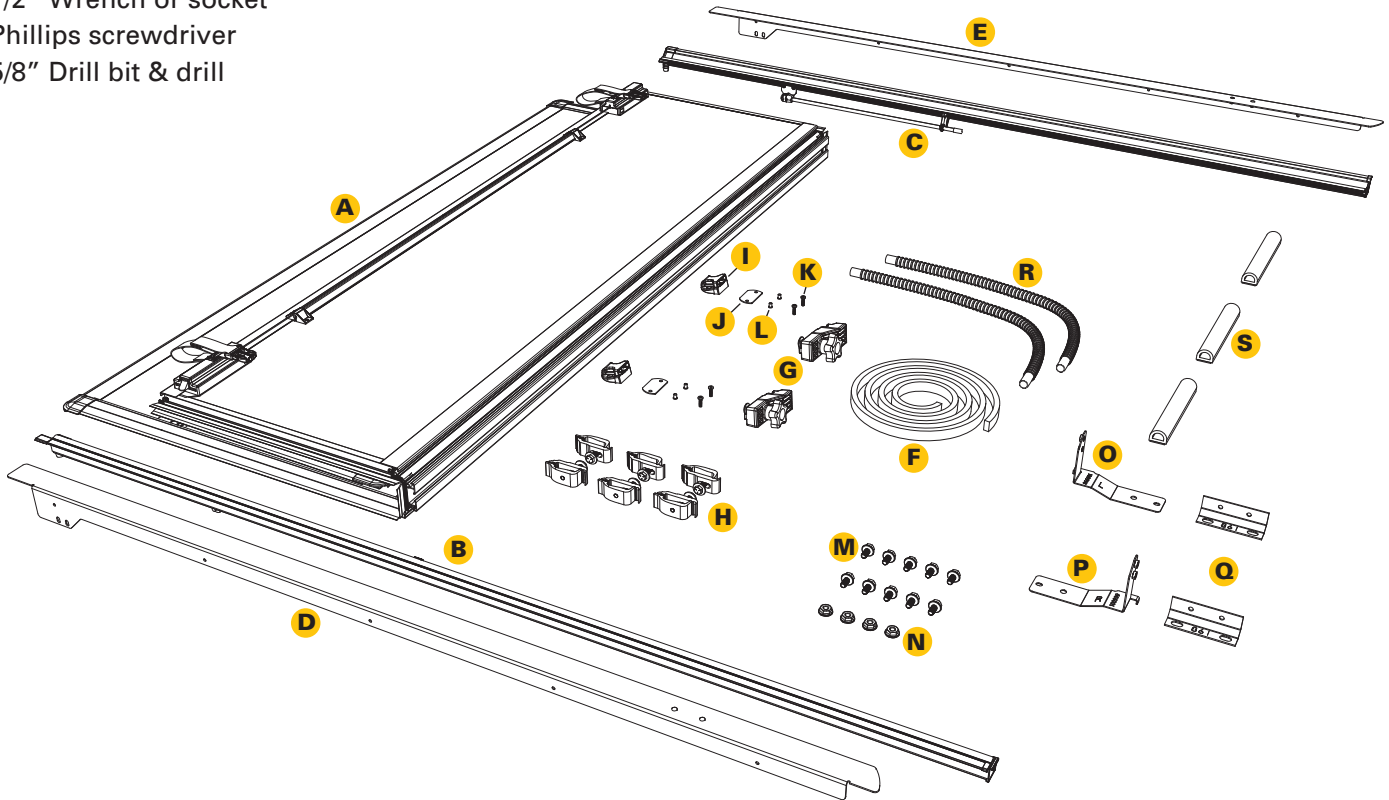

PARTS INCLUDED IN THE BOX

- A** 1x Hard fold cover
- B** 1x Driver side rail
- C** 1x Passenger side rail
- D** 1x Adaptor rail driver side
- E** 1x Adaptor rail passenger side
- F** 1x Bulkhead seal
- G** 2x Cover retainer clamps
- H** 6x Clamps
- I** 2x Buckle ends
- J** 2x Gaskets
- K** 4x Screws
- L** 4x Nutserts
- M** 10x M6 flange mounting bolt
- N** 4x 1/4-20 nuts
- O** 1x Driver side front mounting bracket
- P** 1x Passenger side front mounting bracket
- Q** 2x Rear mounting brackets
- R** 2x Drain tubes
- S** 3x D-shaped cab bumpers

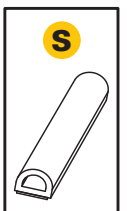
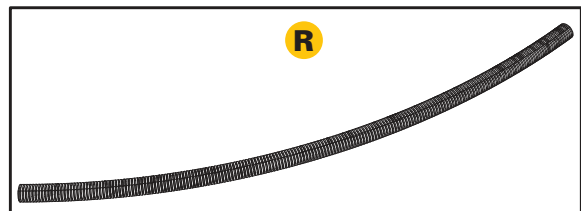
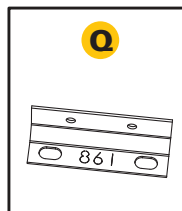
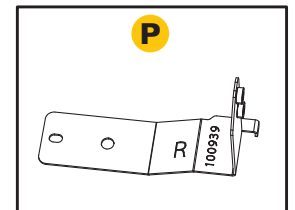
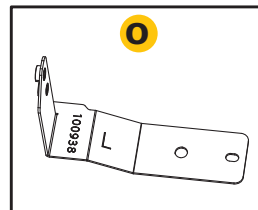
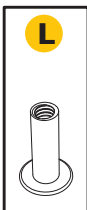
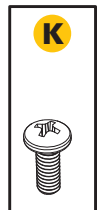
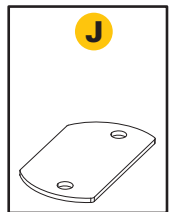
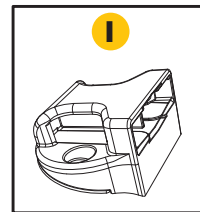
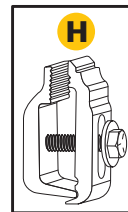
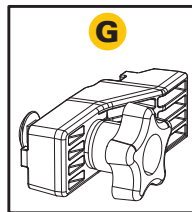
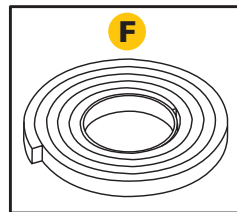

1 Installing Seal: Install bulkhead seal (F) included with cover (A) by cleaning the top of the bulkhead with soap and water to remove dirt and debris. Clean the area with isopropyl alcohol to remove wax or grease and to evaporate any remaining water. Allow the surface to dry. Peel the backing and adhere the seal from one bulkhead edge to the other. Remove any excess with scissors or a utility knife. Apply pressure evenly to the entire seal to ensure proper adhesion. If the truck has a drop-in bedliner, no seal will be needed.

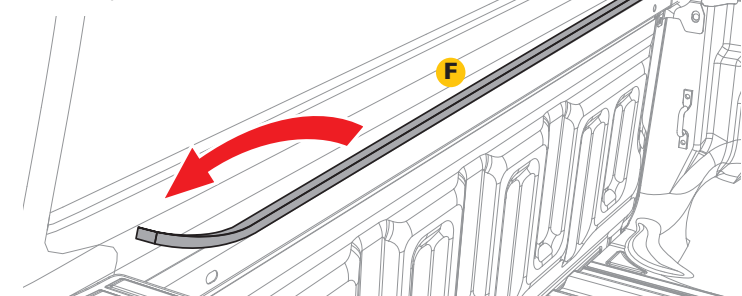

2 Removing Front Accessory Rail: If your Gladiator is equipped with a front accessory rail, it must be removed at this time to allow for the installation of the driver side front mounting bracket (O). Remove the bolts that hold the accessory rail to the bulkhead on both driver and passenger side front corners. If you do not have a front accessory rail, skip to step 4.

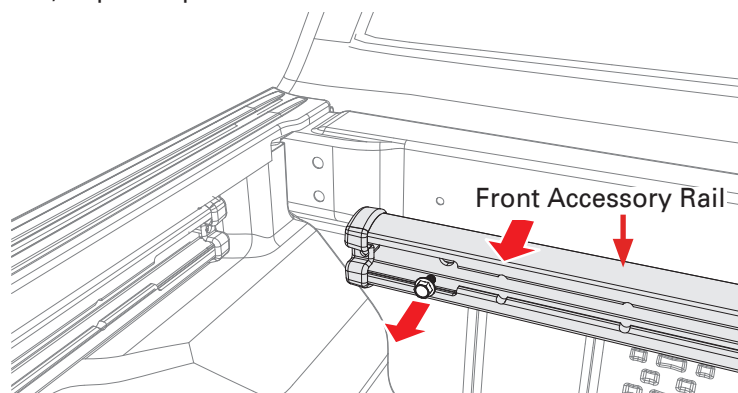

3 Installing Front Mounting Brackets: Use the driver side front mounting bracket (O) labeled with the letter "L". Locate the pre-bent tab on the front bracket and place in the upward most hole located towards the front corner of the bulkhead on both sides. Repeat on passenger side using the passenger side front mounting bracket (P) labeled with the letter "R".

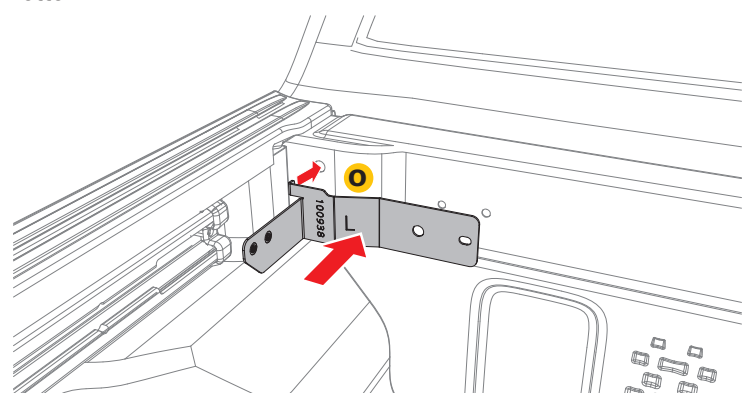

4 If you do not have a front accessory rail, as mentioned in step 2, proceed to install one M6 flange mounting bolt (M) into the front bracket (O) in the second slotted hole to the right as shown. Repeat on the passenger side using the passenger side front mounting bracket (P) labeled with the letter "R".

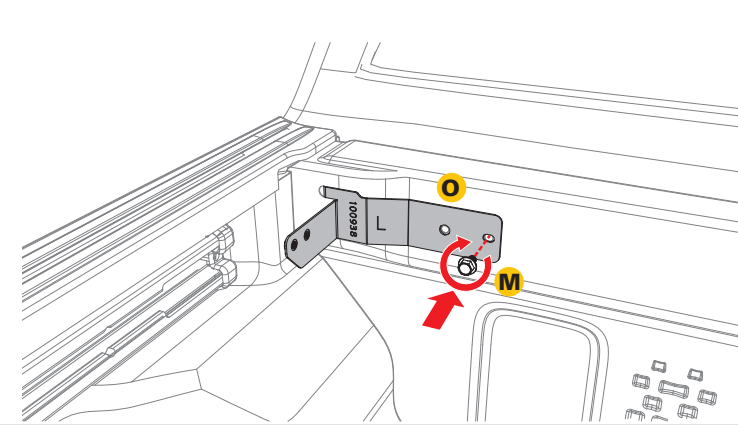

5 If you **DID** remove the front accessory rail, as mentioned in step 2, proceed to install the accessory rail over the front bracket (O) you just installed aligning the holes in both using one M6 flange mounting bolt (M) through both and into the bulkhead. Repeat on passenger side using the passenger side front mounting bracket (P) labeled with the letter "R". Then tighten bolts.

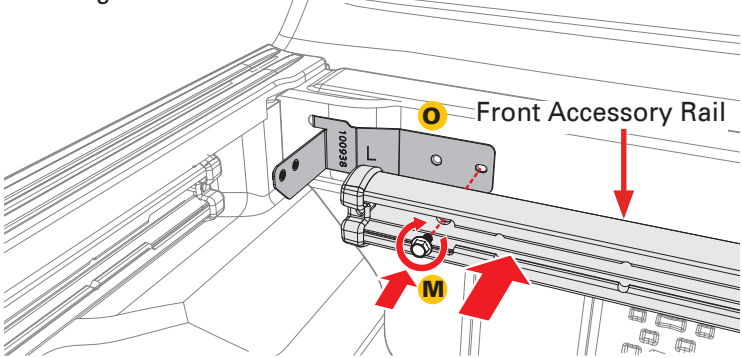

6 Installing Rear Mounting Brackets: Locate the outlined section on the inside of the bed cap towards the taillight well at the rear of the bed on the driver's side. Cut and remove the outlined section of the bed cap to reveal two threaded holes. Locate the rear mounting bracket (Q) and install two of the M6 flange mounting bolts (M) through the bracket and into the threaded holes. Repeat on the passenger side. Do not tighten, leave loose at this time.

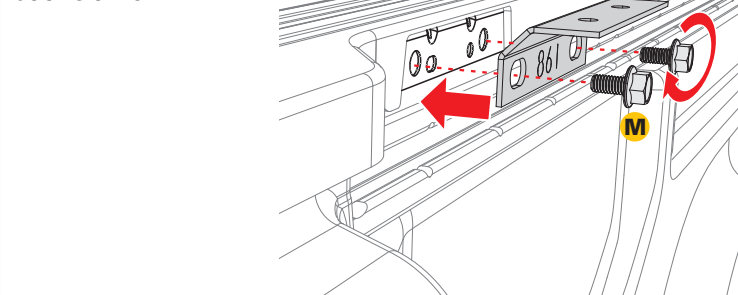

7 Installing Adaptor Rail: Install the adaptor rail driver side (D) and line up the front slotted holes with the holes in the front bracket using two M6 flange mounting bolts (M). Repeat on the opposite side using the passenger side adaptor rail (E). Do not tighten, leave loose at this time.

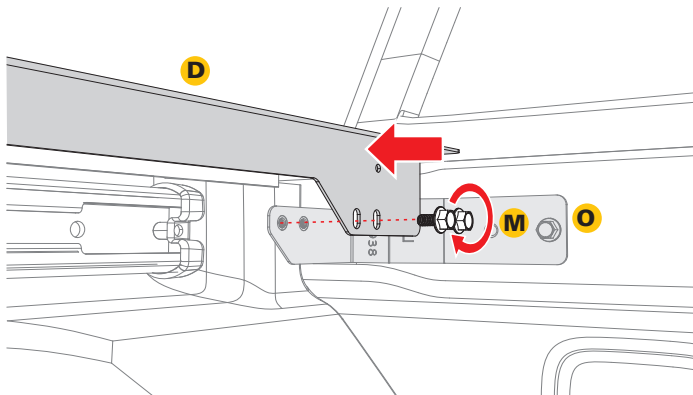

8 Install the adaptor rail driver side (D) by lining up the studs with the holes in the rear bracket using two M6 flange mounting bolts (M) and two 1/4-20 nuts (N). Repeat on the opposite side using the passenger side adaptor rail (E). Now tighten, using a 7/16" socket in front and rear on both sides.

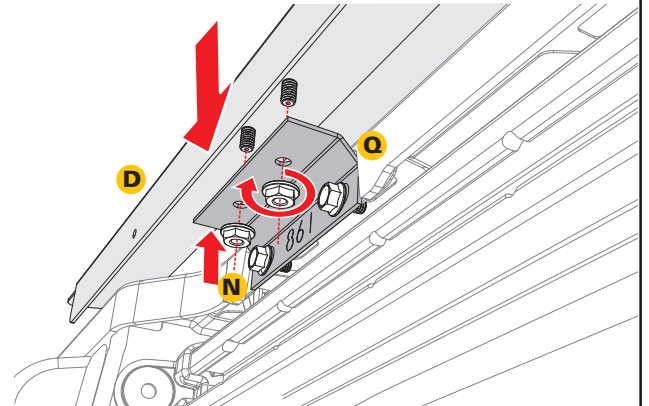

9 Installing Side Rails: Apply downward pressure to the driver side rail (B) on to the adaptor rail driver side (D) clamping both together to the truck bed rail. When tightening each clamp (H) make sure the side rail sits flush and seals properly. A second set of hands may help. Repeat on the opposite side using the passenger side rail (C) and the adaptor rail passenger side (E).

Tip: Mount the center clamp first but do not tighten completely. This will give you the ability to adjust the rail as the outer clamps are attached.

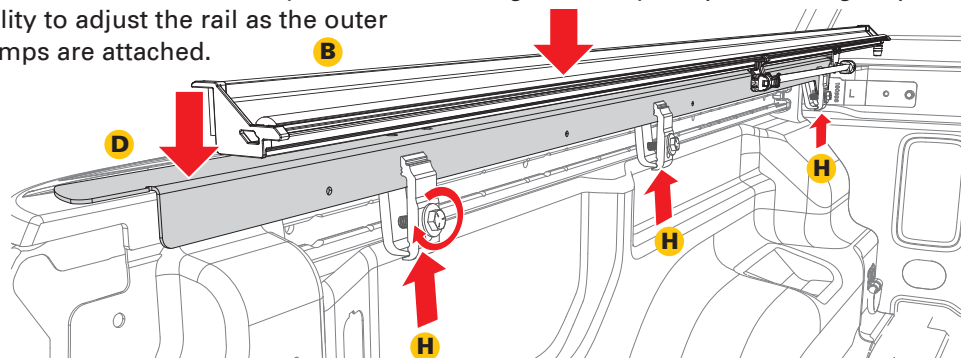

NOTE: If the rails are leaning down, have one person stand on the outside of the bed and slightly roll the rails upward while another person slowly snugs the clamps up. If the clamps are tightened too quickly or overtightened, it will cause the rails to lean down.

10 Attach the drain tubes (R) to the front of the side rails (B & C) to allow water to be diverted out of the truck bed via the rail. The opposite end of the drain tubes can be placed behind a bedliner, through the bed plugs, or by drilling a 5/8" hole in the bulkhead.

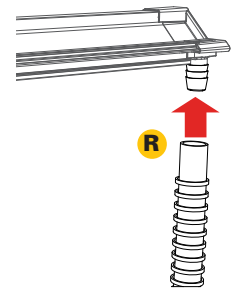

11 Before placing the cover (A) onto the vehicle, slide two cover retainer clamps (G) into the track on the underside of the cover (A) near the cab. Confirm the cover retainer clamps fit properly into the cover rail for optimum fit. Repeat on the opposite side of the cover.

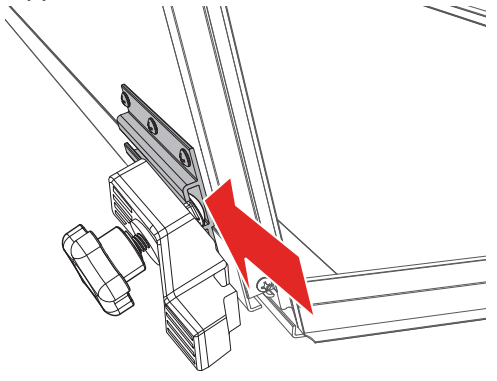

12 First, prep the buckle ends (I) by peeling off the adhesive liner of the gasket (J).

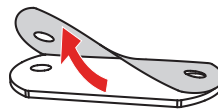

Then adhere the gasket (J) to the underside of each of the buckle ends.

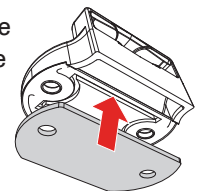

Position the buckle ends (I) with the open side facing the bed cover panel. Use a Phillips screwdriver to install the two buckles into the pre-drilled holes on the front header panel with the provided screws (K) and the nutsert (L) inserted from the backside of the panel. **DO NOT use a screw gun, securely tighten by hand only.**

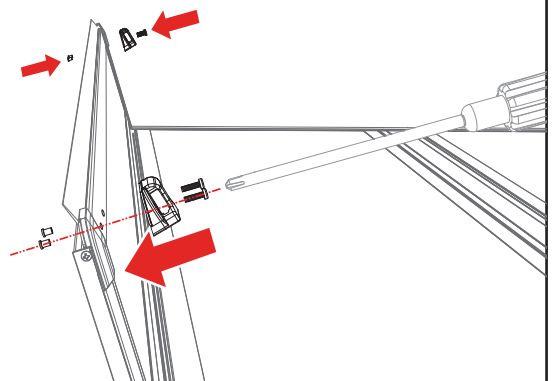

- 13** Set the cover (A) in the folded position on the side rails (B & C) towards the cab of the truck. Confirm the cover is evenly spaced between the rails.

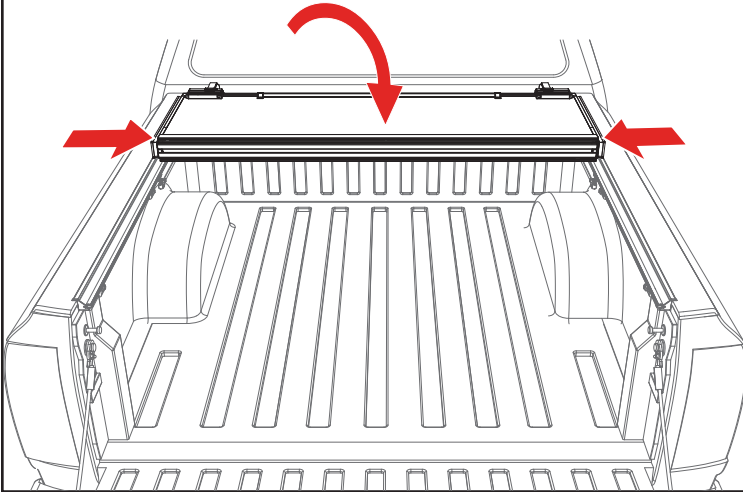

- 14** Confirm the retainer clamps (G) are positioned around the side rails (B & C) correctly as shown below. Tighten the retainer clamps by turning them clockwise until the lock washer is secure.

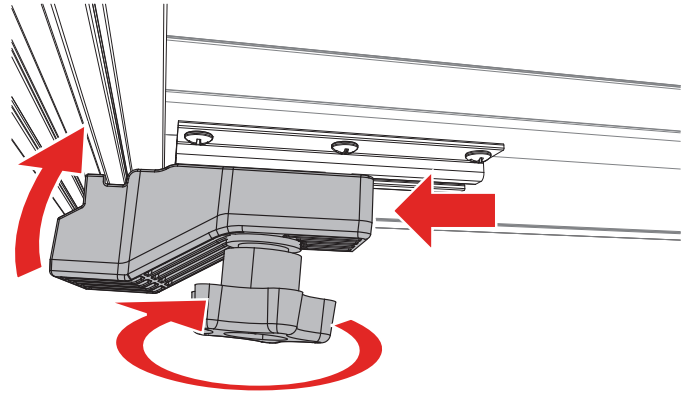

- 15** With the bed cover in the folded position, clean the area where the three D-shaped cab bumpers (S) will go with soap and water to remove dirt and debris. Then clean the area with isopropyl alcohol to remove wax or grease and to evaporate any remaining water, allow the surface to dry. Then install the cab bumpers along the top edge of the cover where it meets the truck cab. Apply pressure to all bumpers to make sure the adhesion is good.

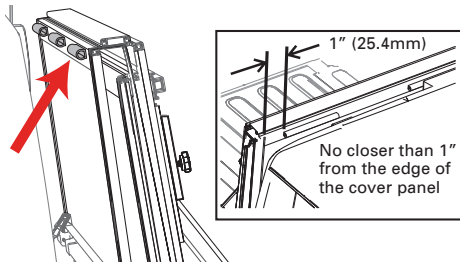

- 16** Unfold the cover (A) towards the tailgate. Then confirm each panel is centered side to side and front to back on the truck bed. If adjustments are needed, loosen the cover retainer clamps (G) and shift the cover until positioned correctly. The rear edge of the cover and tailgate seal should rest on top of the tailgate. For proper sealing, the tail panel will overlap by .5".

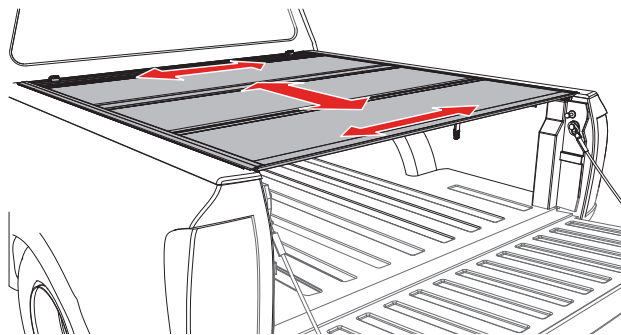

Power Tailgates:
If your truck has a powered opening or closing tailgate ensure the tailgate functions properly with the cover closed and if needed adjust the cover towards the truck cab.

- 17** Check if the latches are hitting or not engaging the side rails (B & C) by releasing each latch. If any of the latches need modifications refer to the Slam Latch Adjustment section on the next page on how to make adjustments.

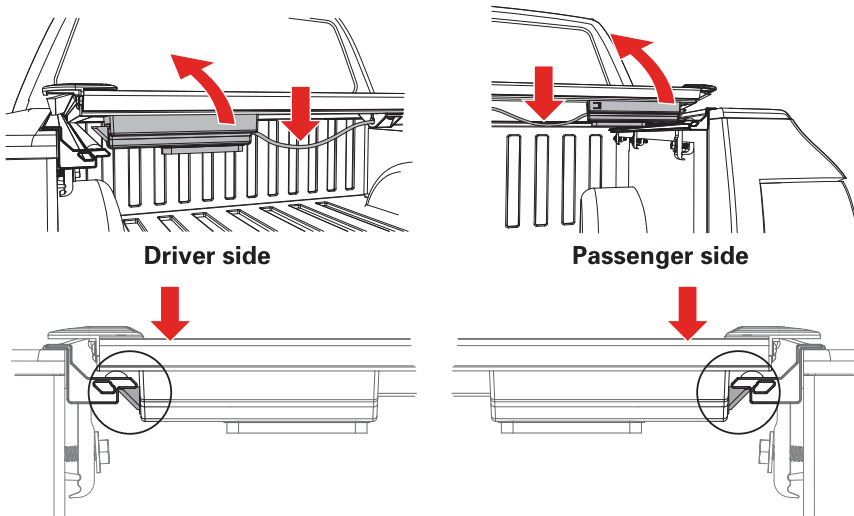

- 18** Retighten the cover retainer clamps once the desired fitment is reached. **You are ready to drive with your cover in the closed position.**

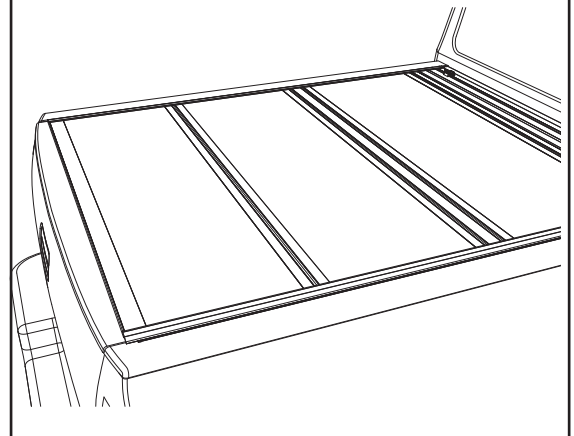

OPENING COVER: Lower the tailgate and pull the cable on either side. While pulling on the cable lift the panel up and towards the cab.

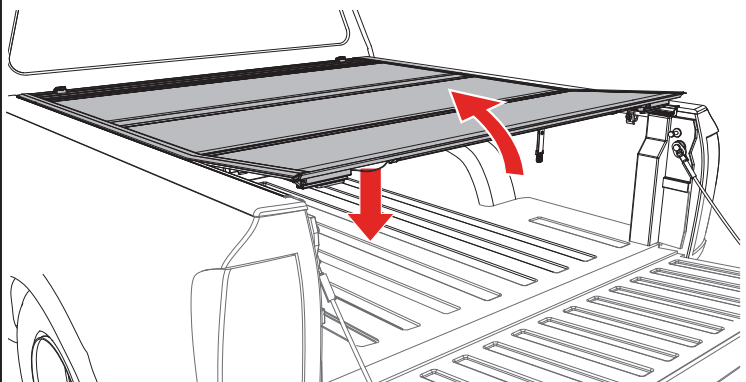

FOLDED UP POSITION: To drive with the cover (A) in the folded up position, use the straps and buckles provided with the cover. Attach the buckle at the bulkhead, then pull the strap to take up the slack and secure the cover.

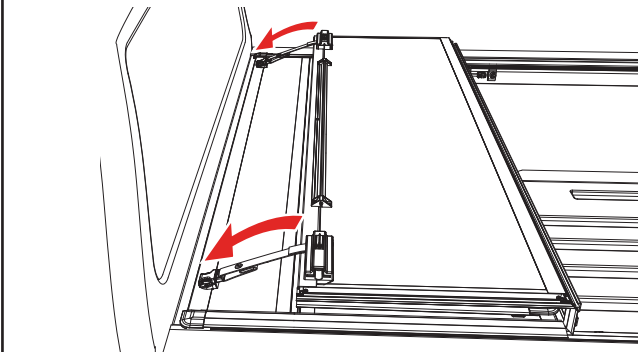

FLIPPED UP POSITION: Fold the cover (A) open and lift it until it's vertical or past 90 degrees towards the truck cab. Then release the prop rod that is attached to the rail. Fold the prop rod over and position it firmly against the vertical plate on the underside of the cover. Then slide the prop rod locks downwards and tighten the knobs to lock it into position. Do this on both sides of the cover. The cover should be firmly in position with little to no movement once the prop rods are locked.

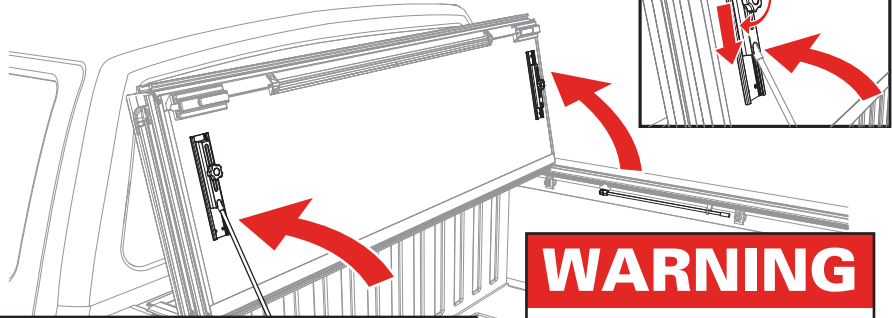

WARNING
Only using the prop rods with the Jeep hard top installed.

Before flipping cover (A) in the up position make sure to stow the straps using the clips on the underside of the folded cover.

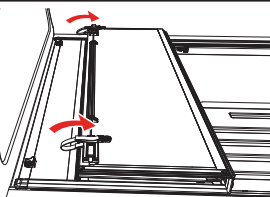

CLOSING COVER: To drive with the cover (A) closed, unhook the buckles and straps from the bulkhead. Stow the straps using the clips on the underside of the folded cover. Fold all panels towards the tailgate making sure that all latches are engaged.

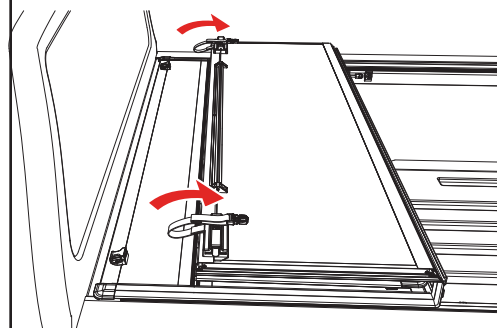

ADJUSTING SLAM LATCH

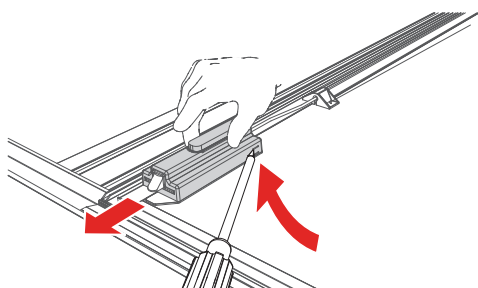

Use a screwdriver to partially pry open the tab on the latch housing. At the same time slide the housing away from the latch assembly.

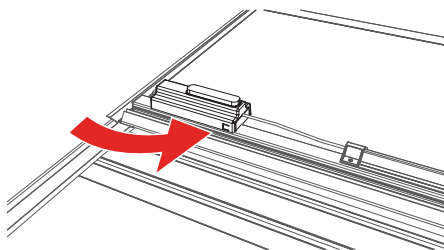

Note: that the tab is located on the opposite side of the housing on the passenger side of the cover.

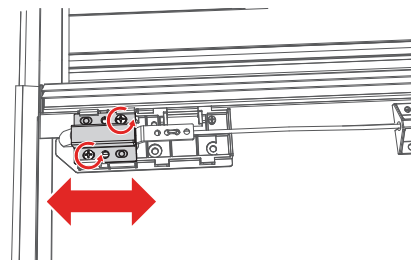

With the latch cover removed, loosen the screws and move the latch bracket to adjust. Retighten the screws. Slide the latch housing back on.

CARE AND MAINTENANCE

The truck bed cover requires occasional cleaning with mild automotive soap and water only. Avoid using abrasive cleaners as they may dull the finish. Some chemicals and fluids such as insect repellents, oils, solvents, and lubricants could potentially damage the rubber hinges and seals and void the warranty.

CAUTION

Always read the ingredients of any product you are using to clean your truck bed cover. Make sure that you use only products that are safe for use with rubber. Many cleaners contain chemicals that could permanently discolor or damage your hinges and seals.

Periodically check that your cover is securely attached to your truck bed and working as intended. Inspect all hardware such as clamps and cover retainer clamps to ensure they are properly installed and working as intended. Covers that are used at high frequency or subject to rough roadways and/or heavy vibration conditions may cause the cover to require adjustment.

It is also recommended that you regularly inspect and service each panel latch. Clean away any excess dirt or grime. Ensure all latches move freely in and properly engage the side rail to provide optimal performance and security.

SAFETY INSTRUCTIONS

- DO NOT place objects on or against cover or framework.
- DO NOT tie cargo to truck bed cover or framework.
- DO NOT operate vehicle with objects on top of the cover.
- NEVER allow children or pets to occupy the truck bed with the cover in the fully closed position.
- The cover is not airtight. Special care is required to keep cargo clean and dry.
- Truck bed covers will not prevent theft of contents inside the truck bed.

TROUBLESHOOTING TIPS

Leaning Rails: If the rails are leaning down, have one person stand on the outside of the bed and slightly roll the rails upward while another person slowly snugs the clamps up. If the clamps are tightened too quickly or overtightened, it will cause the rails to lean down.

Water Intrusion: Make sure the retaining clamps are tight and properly engaged to the side rails. Check that the bulkhead seal is in place and the cover is resting on it. Make sure that all latches are engaged to the side rails and adjust if needed. Check that the side rails are installed flush with the top of the bed rail.

Sticking Latch: The cable could be pinched in or under the cable guide extrusion. Loosen the three screws on the center cable cover (bar), located in the middle of the panel. Slightly lift up on the cable guide extrusion. Pull on both sides of the cable.

Wavy Side Seal: The seal may be wavy when removed from the box. Allow ample sunlight for seal to lay flat and relax.

LIMITED WARRANTY

WARRANTY COVERAGE

This truck bed cover is warranted against defects in materials or workmanship as follows. This warranty is void if the product has been damaged in an accident, or due to neglect, unforeseeable use, improper installation, improper servicing, or other cause not arising out of defects in material or workmanship.

MX4 & F1 - The truck bed cover carries a limited warranty for **five (5) years** from the original date of purchase, subject to the terms below.

G2 & FIBERMAX - The truck bed cover carries a limited warranty for **three (3) years** from the original date of purchase, subject to the terms below.

WARRANTY IS NOT TRANSFERABLE

The warranty is to the initial owner purchasing the truck bed cover and it is not transferrable to a subsequent end user. Proof of purchase may be required to enforce these warranty rights.

WARRANTY CONDITIONS

Failure to follow care and use instructions will void the warranty.

- Clean with mild automotive soap and water only.
- Cover must be secured at all points when vehicle is in motion.
- Check all clamps and retention mechanisms for tightness after a week of driving following installation (or re-installation) of the cover and periodically thereafter.
- Before opening, the cover must be free of all foreign materials including snow and ice.
- Do NOT tow your vehicle from the rear with the cover on your vehicle. If towing from the rear is required, the cover MUST be removed from the vehicle and properly stored.

WARRANTY PERFORMANCE

If all warranty conditions are met, a defective truck bed cover or hardware component will either be repaired or replaced (at our option). We reserve the right, for any warranty, to substitute a newer model or bed cover having similar form and function, to offer a warranty discount on an entire replacement system, and/or provide remedies other than those mentioned in this document.

WARRANTY RETURN

A Return Material Authorization number must be obtained from our Customer Service Department prior to returning any product. We may require the original item to be returned postage prepaid for final determination. Shipping charges will apply for any repair or replacement. Other than postage or shipping charges, no charge will be made for repair or replacement under this warranty.

This warranty gives you specific legal rights. As an owner, you may also have additional rights and remedies under the laws of your state.

WARRANTY REGISTRATION

Warranty registration must be on file and/or proof of original purchase (detailed and dated receipt) required for warranty to be effective.

<https://realtruck.com/bak-warranty>

**REGISTER
YOUR
WARRANTY
ONLINE**



Serial Number _____

Date of Purchase _____