



**DOWNLOAD COLOUR
INSTALL MANUALS AT
www.bddiesel.com**



RoadMaster 10R80 Transmission

1064612	2018-2020 F150 V6 2WD 10R80 Transmission
1064614	2018-2020 F150 V6 4WD 10R80 Transmission
1064622	2018-2020 F150 V8 2WD 10R80 Transmission
1064624	2018-2020 F150 V8 4WD 10R80 Transmission
1064612SS	2018-2020 F150 V6 2WD 10R80 Transmission with TC
1064614SS	2018-2020 F150 V6 4WD 10R80 Transmission with TC
1064622SS	2018-2020 F150 V8 2WD 10R80 Transmission with TC
1064624SS	2018-2020 F150 V8 4WD 10R80 Transmission with TC

Table of Contents

Table of Contents.....2

Introduction.....2

Tools Required for Installation2

Removal/Installation.....2

 Removal2

 Installation13

Line Pressure Checks.....27

Introduction

BD's RoadMaster 10R80 is our remanufactured transmission made for stock or slightly upgraded F-150s. In this transmission we put in new OEM clutches and steels, increase line pressure, and install a new aluminum deep sump oil pan with a drain plug.

Tools Required for Installation

- Ford tool, torque converter retainer – 307-346 (optional)
- 307-569 Disconnect Tool TOC Line (optional)

Removal/Installation

Disconnect both vehicle batteries before installation for safety.

Removal

1. Put the vehicle into NEUTRAL and lift it onto a hoist.

Remove all underbody shields.
Remove skid plate

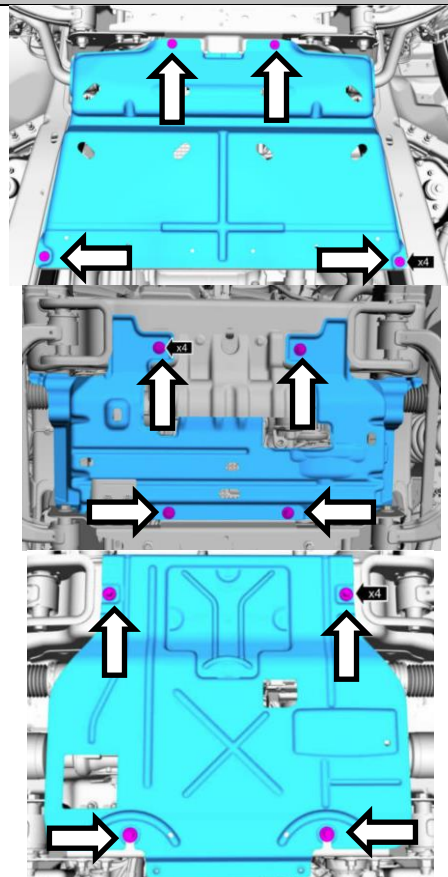

2. Open the starter motor plastic cap.

(1) Remove the starter solenoid battery cable nut and disconnect the cable.

(2) Remove the starter motor solenoid control wire nut and disconnect wire.

(3) Remove the start ground cable nut and disconnect cable.

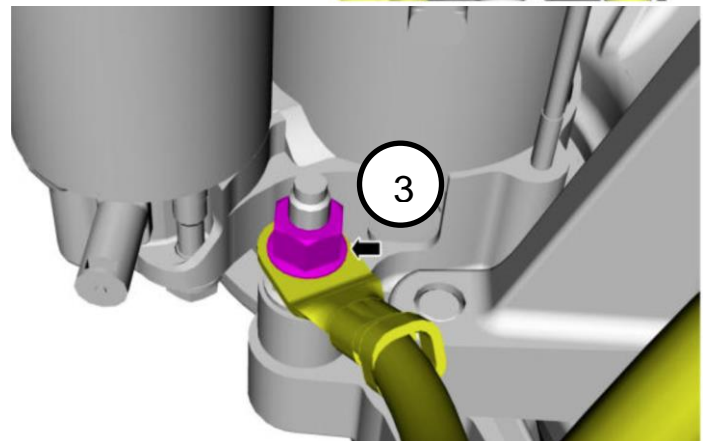
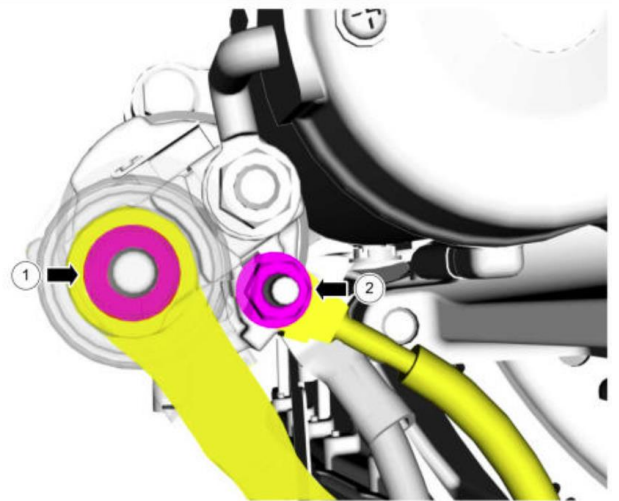

3. Remove the starter motor's three bolts and remove starter.

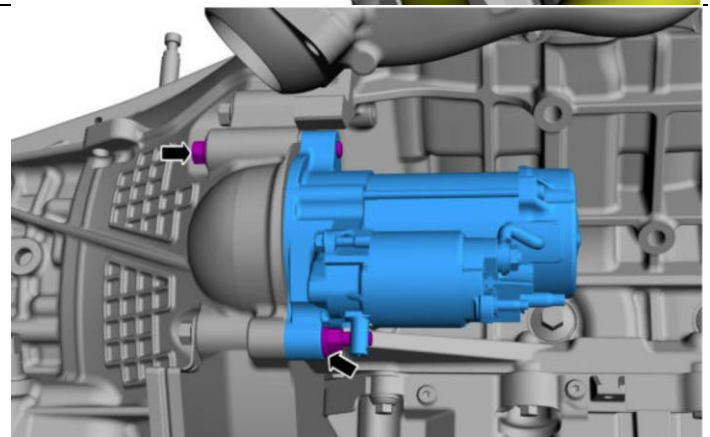

4. (1) Move the transmission fluid cooler inlet tube heat shield aside.
(2) Disconnect the transmission fluid cooler inlet tube secondary latch.

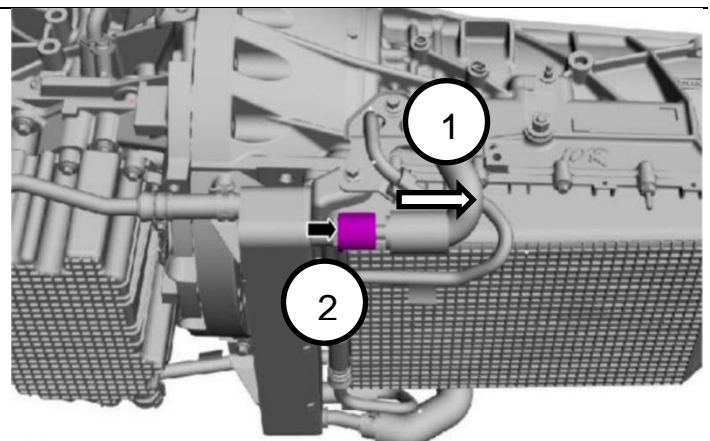

- 5. With the special tool (307-569), disconnect the transmission fluid cooler inlet tube from the cooler.

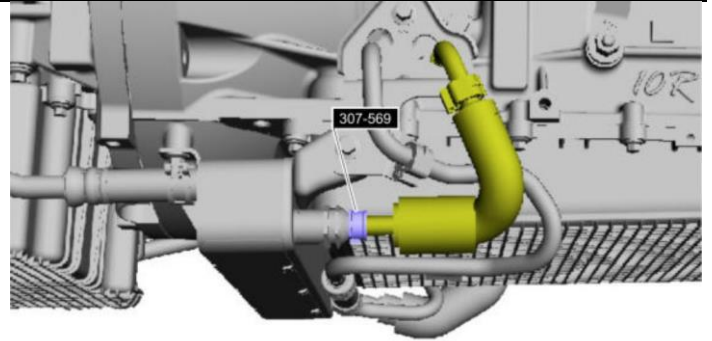

Note:

- Be ready to catch dripping fluid.

- 6. (1) Move the transmission fluid cooler outlet tube heat shield away.
(2) Remove the transmission fluid cooler outlet tube secondary latch.

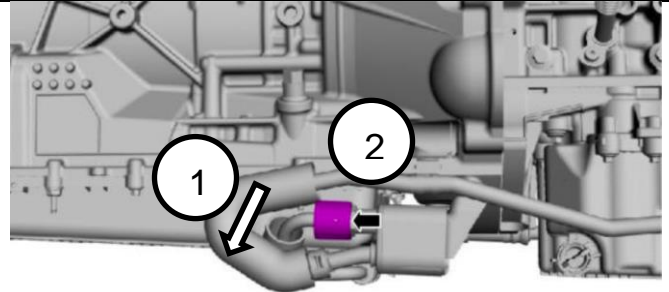

- 7. With the special tool (307-569), disconnect the transmission cooler outlet tube.

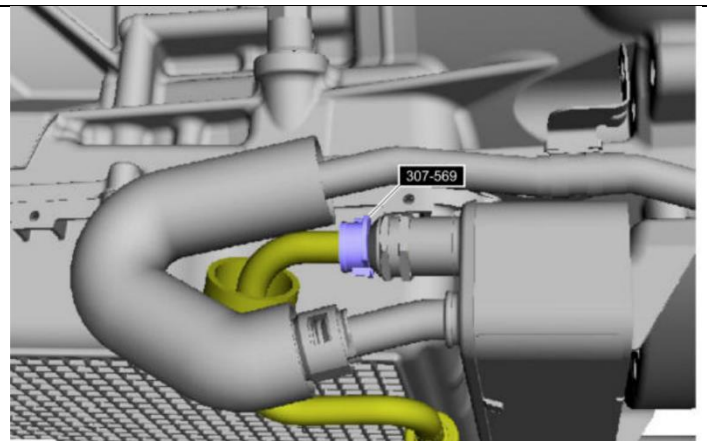

- 8. (1) Disconnect the coolant hoses from the cooler.
(2) Loosen the coolant hose clamp.
(3) Remove the cooler bolts.
(4) Disconnect the cooler off of the hose and remove.

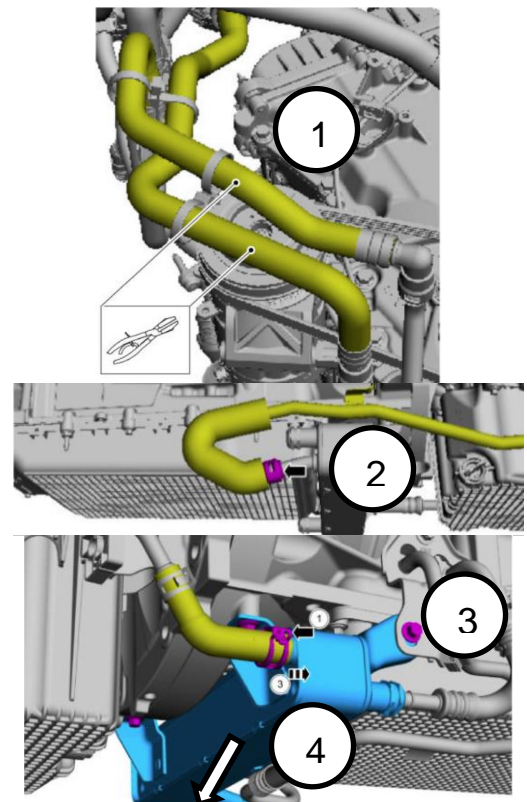

Note:

- You may want to clamp the hoses to minimize leaking coolant.

9. To maintain alignment during installation, index-mark the driveshaft flange to the pinion flange.

Remove the driveshaft flange to the pinions flange bolts.

Note:

- OEM specifications recommend to replace these bolts.

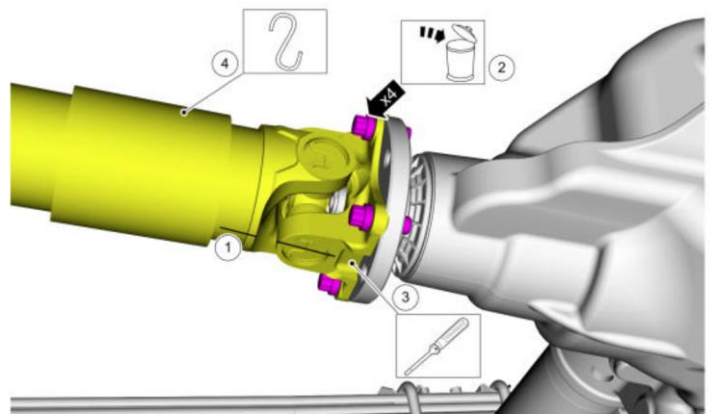

For 2WD:

10. Index mark the driveshaft flange to the transmission flange for alignment when installing.

Remove the bolts and separate the driveshaft flange from the transmission flange.

Note:

- OEM specifications recommend to replace these bolts.

For 4WD

11. Slide the rear drive shaft out of the transfer case.

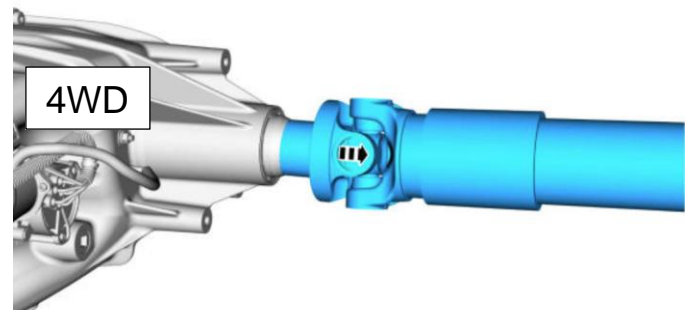
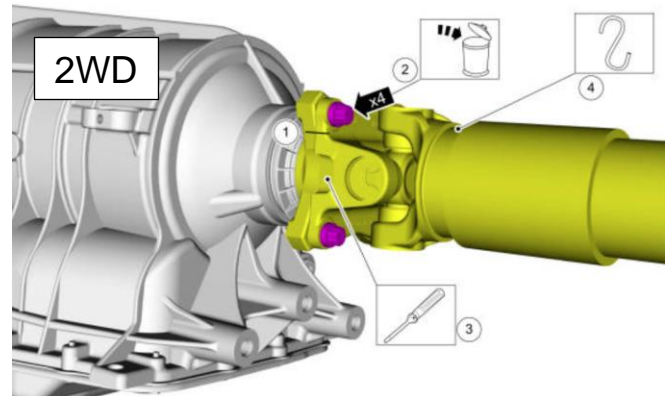

If equipped with two-piece driveshaft.

12. Remove the carrier bearing bolts and driveshaft.

Note:

- OEM specifications recommend to replace these bolts.

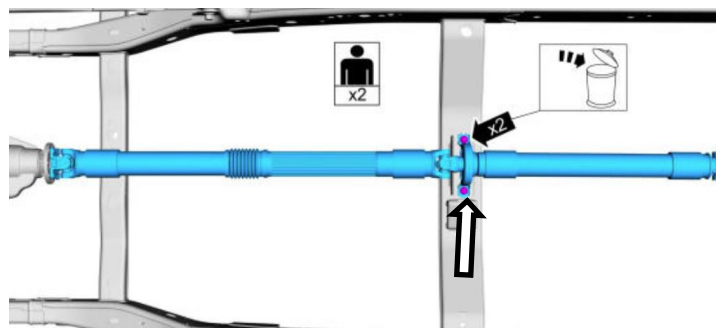

13. Unbolt the stabilizer bar brackets and allow bar to swing down.

Note:

- OEM specifications recommend to replace these bolts.

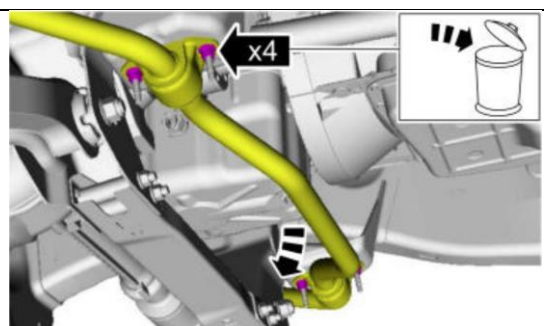

**Steps 14-17 is for 4WD
Skip to step 18 for 2WD**

- 14. Index-mark the front driveshaft flange CV joint to the pinion flange cup, and then remove the bolts and retaining straps.

Note:
OEM specifications recommend to replace these bolts.

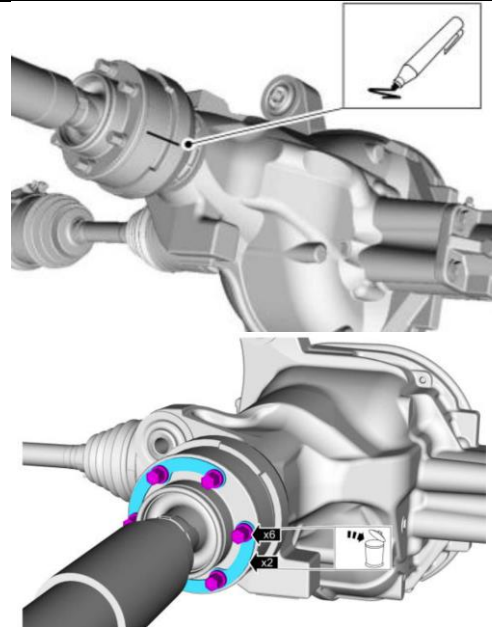

- 15. Index-mark the front driveshaft flange CV joint-to-transfer case flange cup and then remove bolts and retaining straps.

Note:
• OEM specifications recommend to replace these bolts.

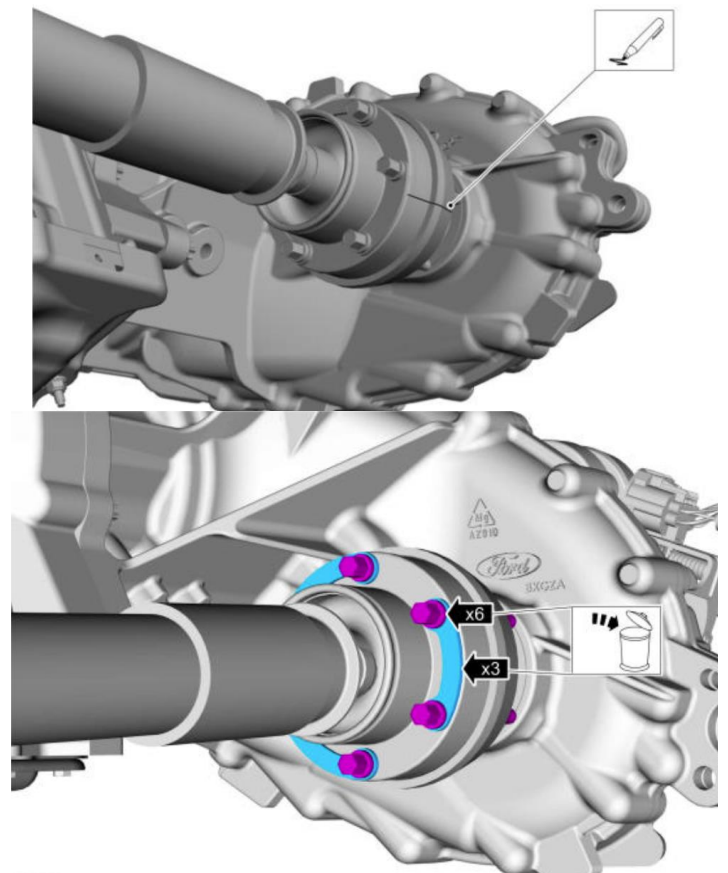

- 16. Remove the front driveshaft.

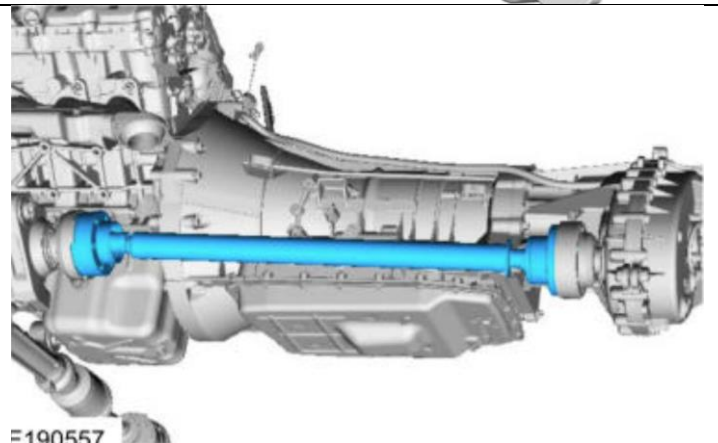

17. Remove the LH isolator cap and bolt.

Remove both RH and LH transmission insulator bolts.

Note:

- OEM specifications recommend to replace these bolts.

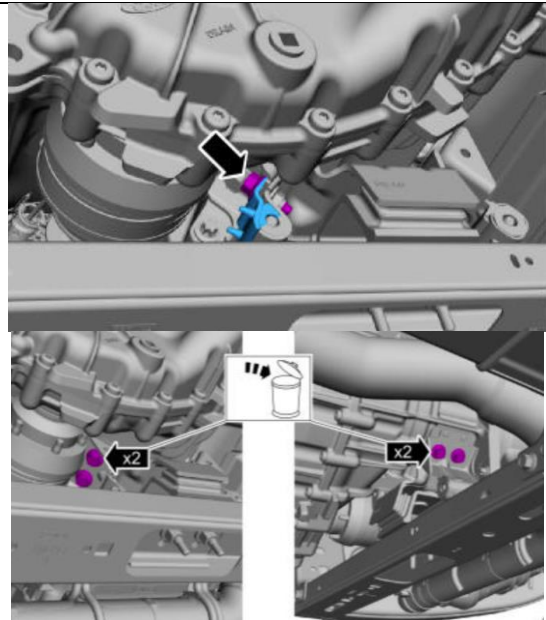

18. Remove the transmission fluid cooler tubes.

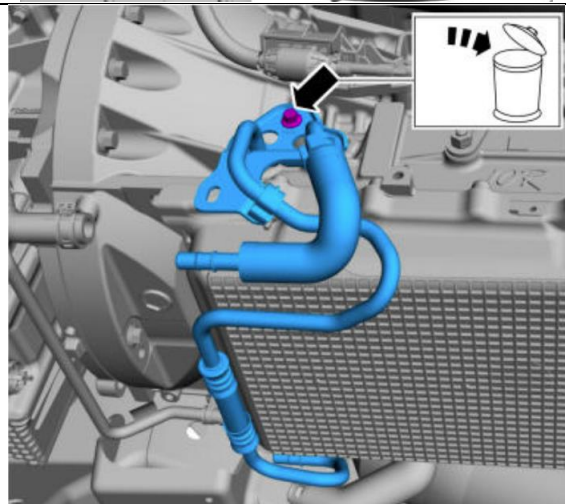

19. Remove the heatshields, and then remove the pan to drain the fluid.

Once fluid is drained, install pan back on. No need to torque.

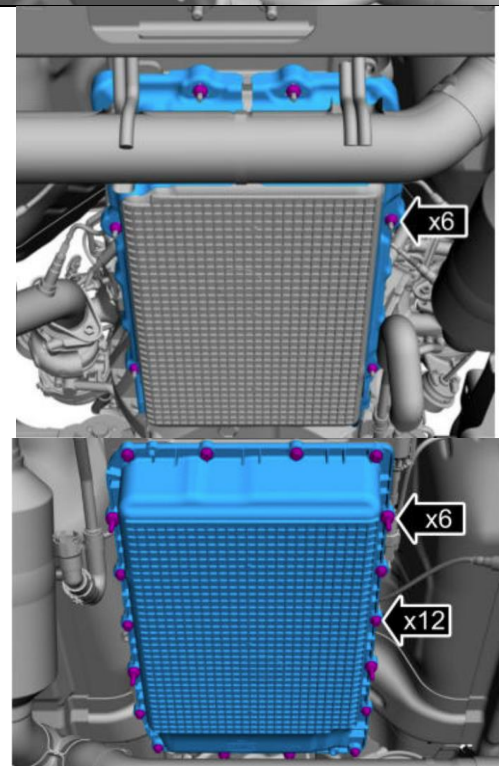

20. With a high-lift transmission jack, support the transmission securely!

Important: Secure the transmission to the jack with a safety strap, and ensure the jack makes contact on the outer ribs of the pan.

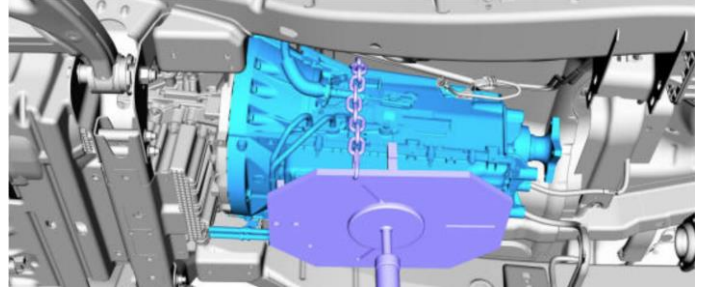

21. Disconnect both the HO2S electrical connectors.

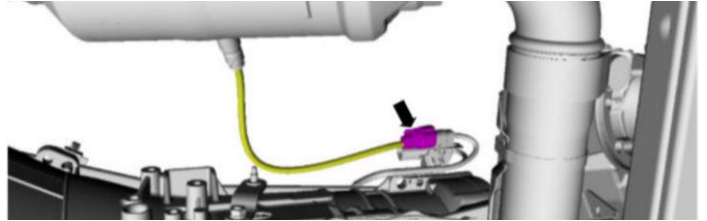
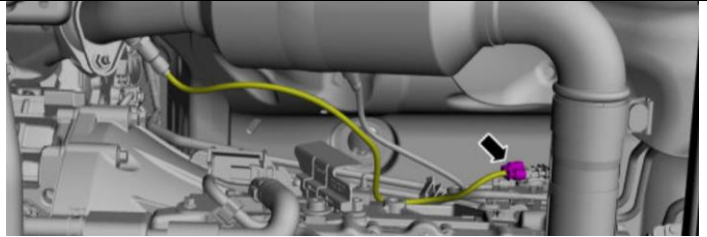

22. Remove the LH catalytic converter nut, then loosen the clamp to remove the catalytic converter.

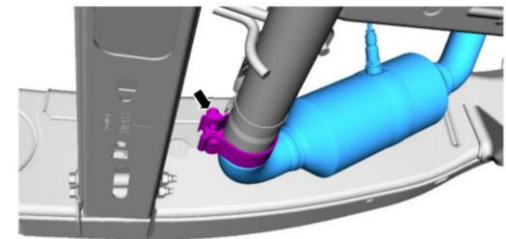
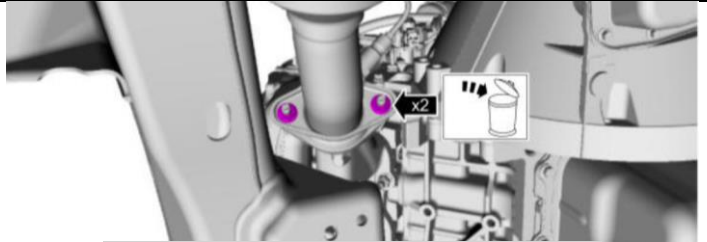

Note:

- OEM specifications recommend to replace these bolts.

23. Remove x4 bolts and curved skid plate.

Next remove wiring harness on cross member by removing x2 bolts.

Position wiring harness aside.

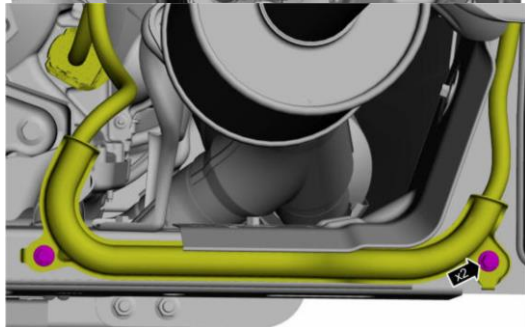
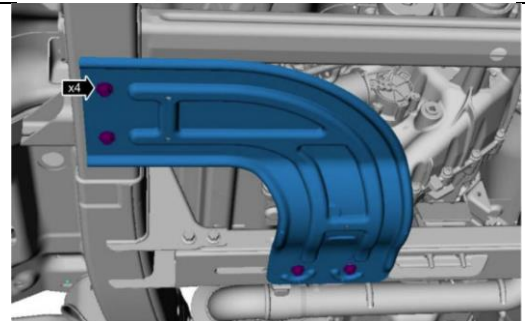

- 24. If equipped, remove both the LH and RH exhaust heat shield bolts from transmission crossmember.

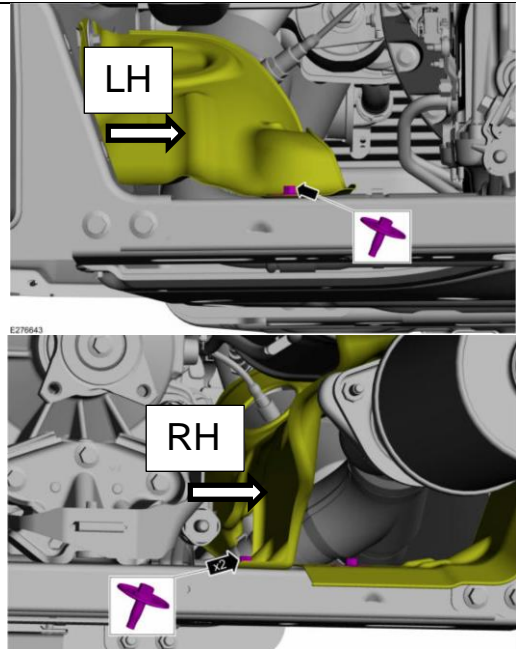

- 25. (1) Remove the transmission support crossmember fasteners.
- (2) Remove the transmission mount nuts and remove the transmission support crossmember.

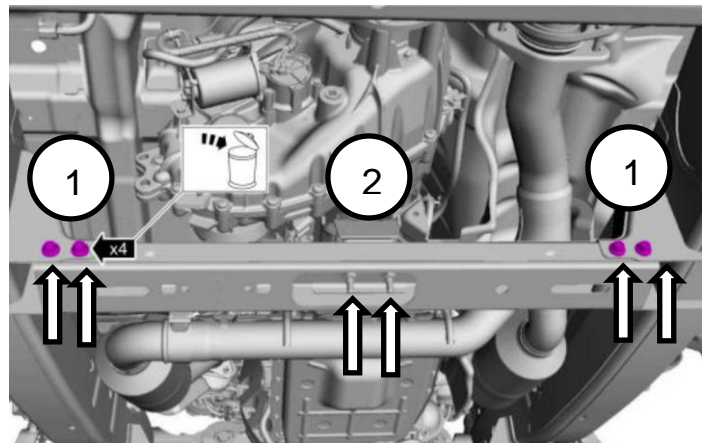

Note:

- OEM specifications recommend to replace these bolts.

For 2WD

- 26. Remove transmission support insulator bolts and washers and remove the support insulator.

Note:

- OEM specifications recommend to replace these bolts.

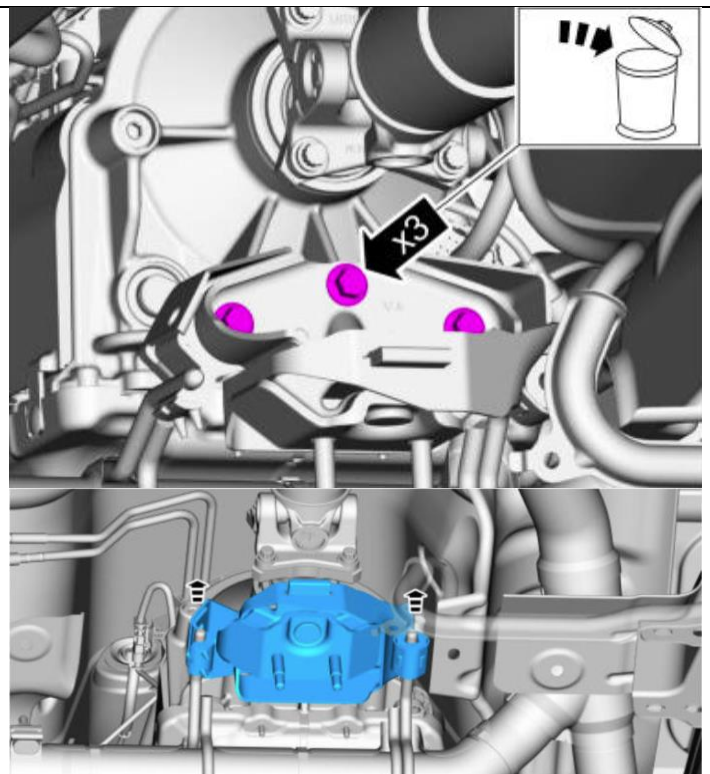

For 4WD

27. Remove transmission support insulator bolts.

Remove the support.

Note:

- OEM specifications recommend to replace these bolts.

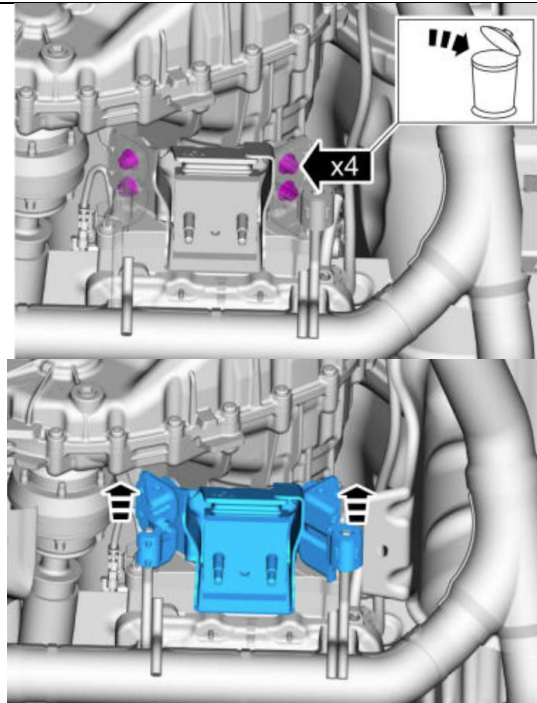

28. Disconnect RH catalyst monitor sensor and RH HO2S electrical connectors.

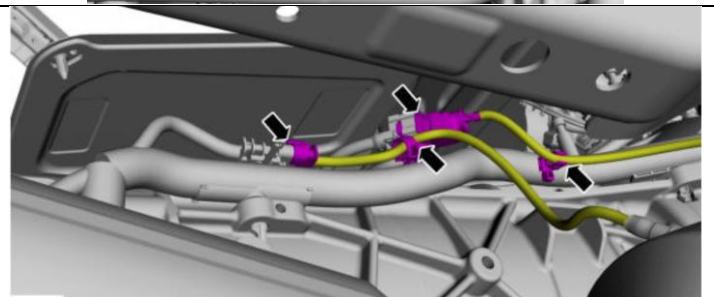

29. Remove bolts from the catalytic converter flange to the muffler inlet pipe.

Then remove catalytic converter.

Note:

- OEM specifications recommend to replace these bolts.

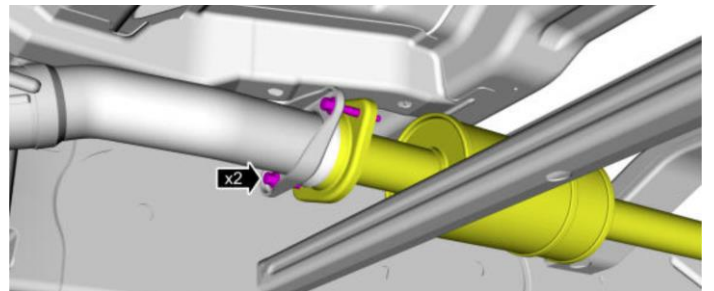

30. **If equipped**, remove splash shield by removing one bolt.

Then remove the bolts and disconnect the selector lever cable and move aside.

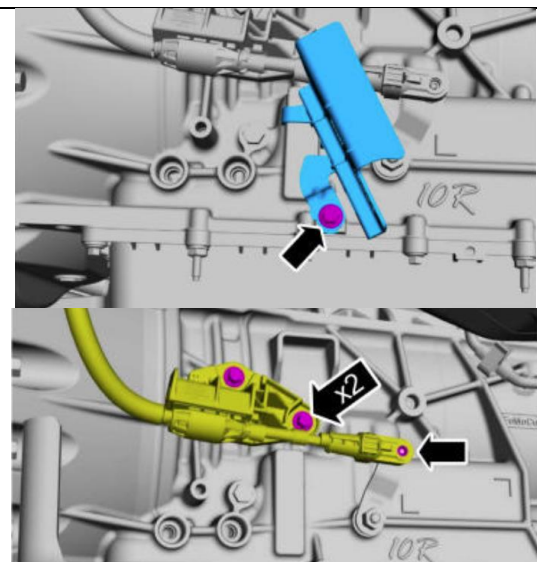

31. Remove fuel line bracket bolt.

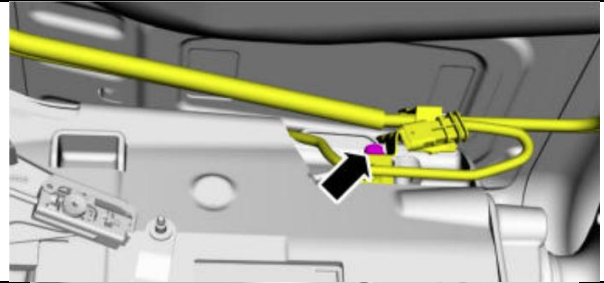

For 4WD only

32. Disconnect the transfer case vent tube.

Also remove the transfer case electrical connector.

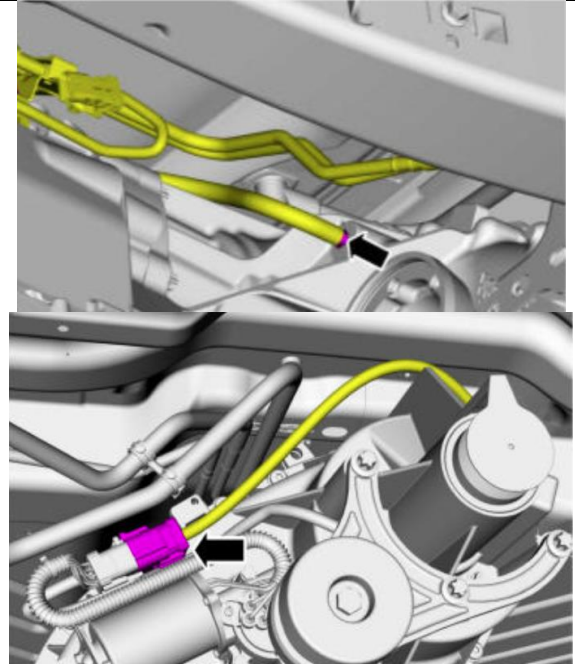

33. Disconnect the transmission electrical connector.

Remove the retainer, and move the wiring harness aside.

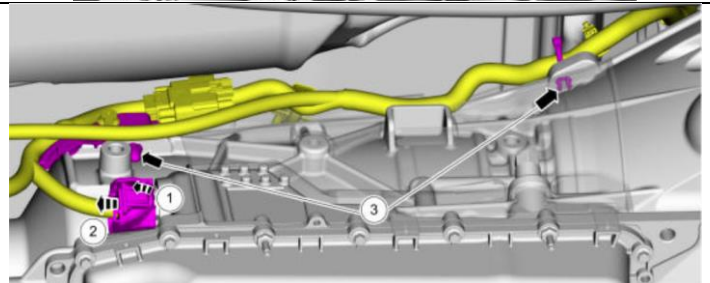

34. Remove the rubber torque converter nut access cover, then index mark one stud and flexplate for assembly.

Then remove torque converter nuts (qty 4).

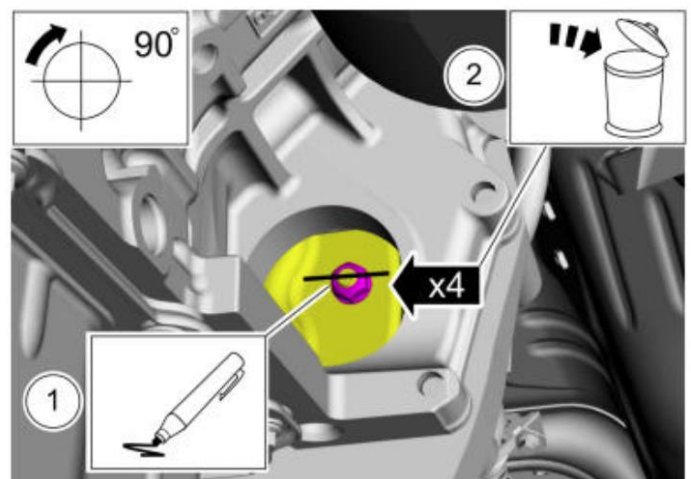
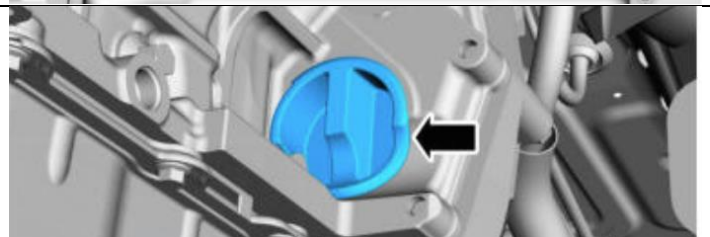

Notes:

- Using the crankshaft pulley bolt, turn the engine clockwise.
- OEM specifications recommend to replace these nuts.

35. Remove all bellhousing bolts (qty 9).

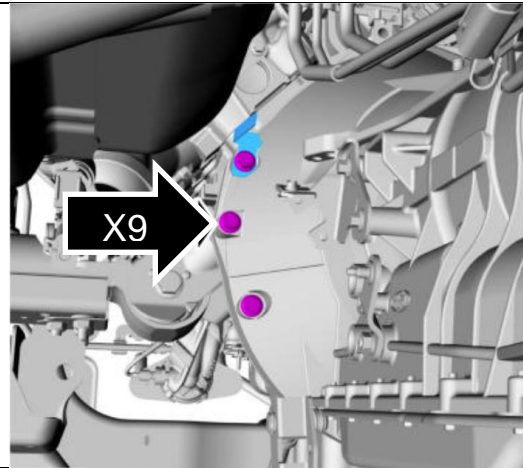

For 2WD

36. Using the high-lift transmission jack, remove the transmission.

Note:

- May use a torque converter retaining tool (307-346) if needed.

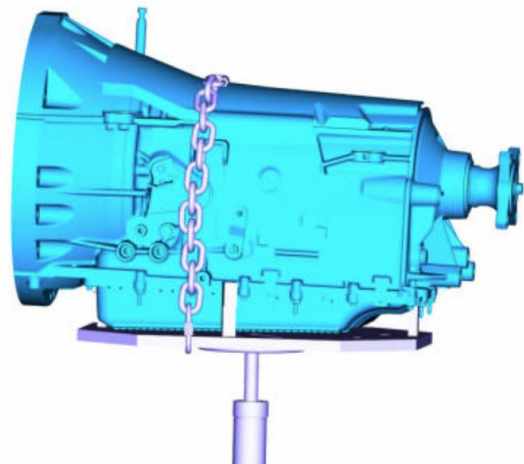

For 4WD

37. Ensure the transmission is secure on the transmission jack. Slide transmission towards the rear of the vehicle.

Tilt the front of the transmission down while removing from vehicle.

Note:

- Important! Torque converter retaining tool (307-346) is recommended.

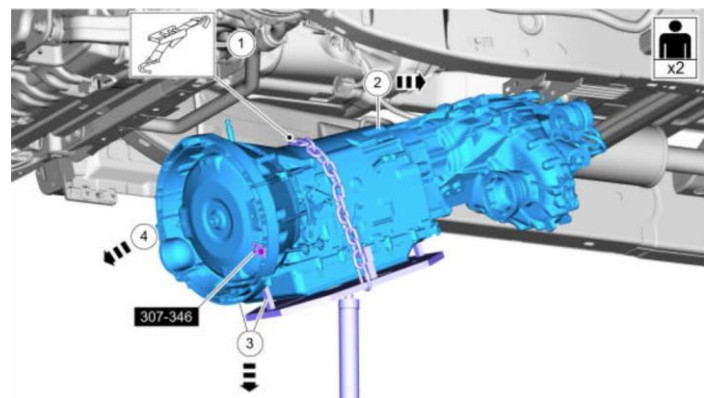

38. To remove the transfer case, remove the 9 bolts.

Note:

- OEM specifications recommend to replace these bolts.

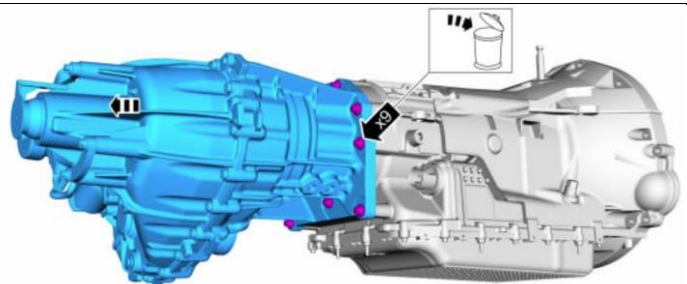

Installation

1. Lubricate the torque converter pilot hub with Multi-Purpose Grease Spray.

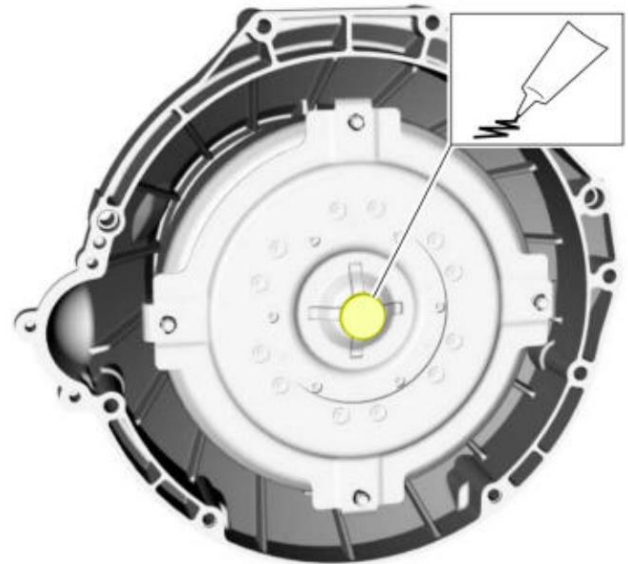

2. Install new dowel pins in the engine block if they were taken out during removal.

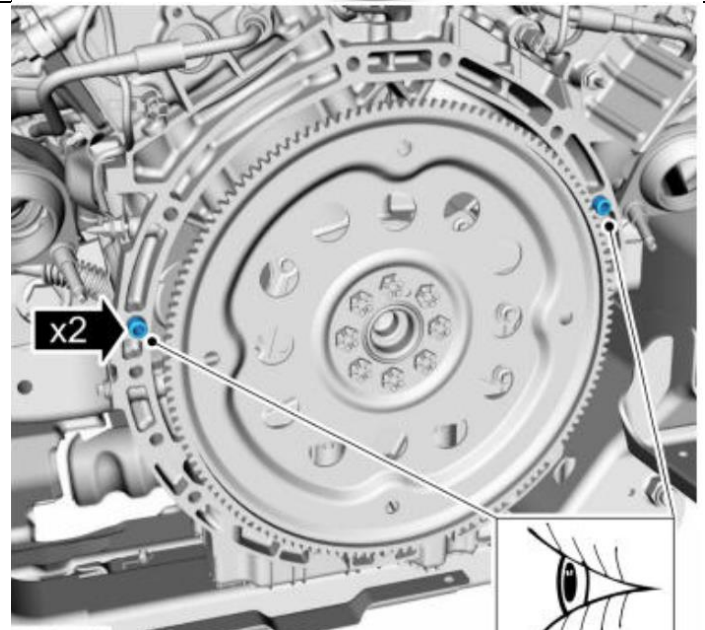

For 4WD

3. Connect the transfer case with the 9 bolts.

Torque: 150lb.in (17Nm)

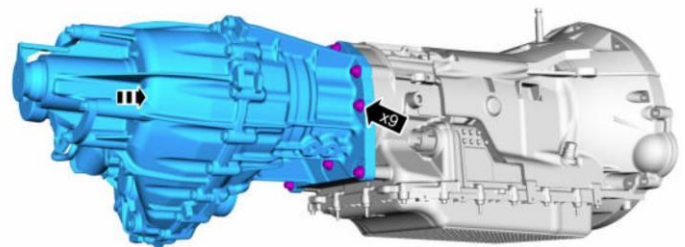

Ensure that transmission is securely mounted onto the jack.

For 4WD

- Tip front downwards (as shown) in order to put transmission in place.

For 2WD

- Raise the level transmission into place.

Note:

- May use a torque converter retaining tool if needed.

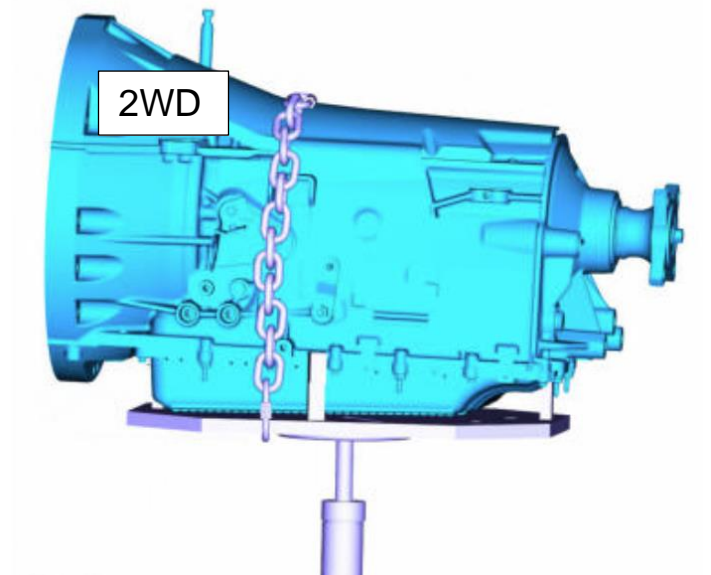
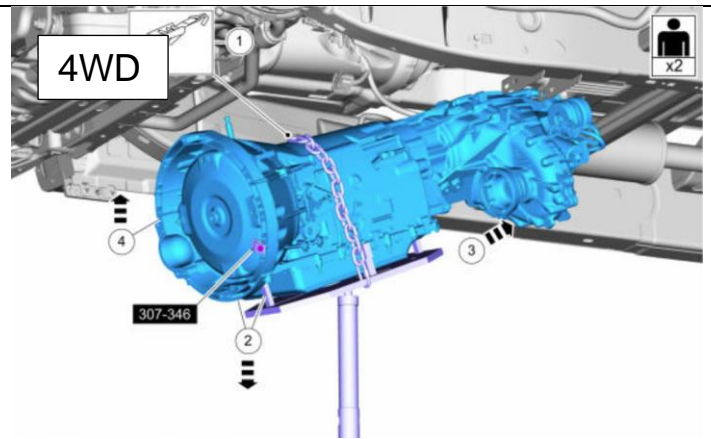

- Align torque converter to the index-marks made during removal.

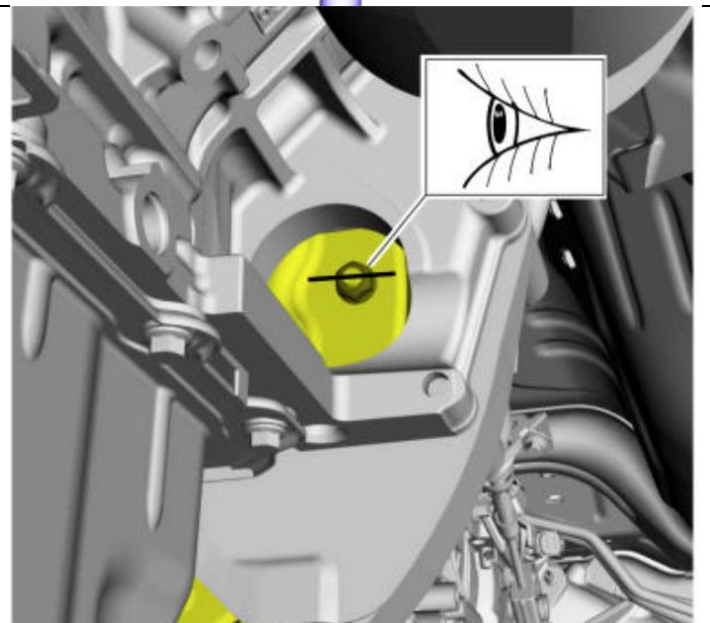

7. Install x3 top bellhousing bolts.
Install x3 LH bellhousing bolts.
Install x3 RH bellhousing bolt.

Torque: 35lb.ft (48Nm)

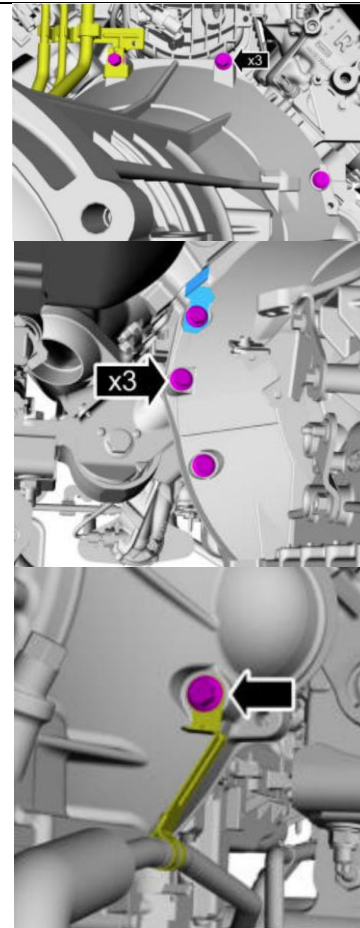

8. Install lower bellhousing bolts.

Torque: 26 lb.ft (35Nm)

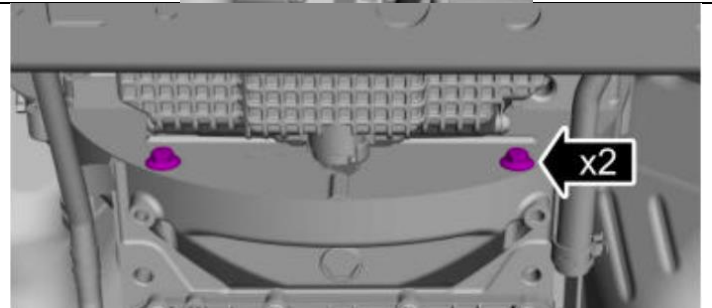

9. Install torque converter nuts (qty 4).

Then install rubber cover.

Torque: 30lb.ft (40 Nm)

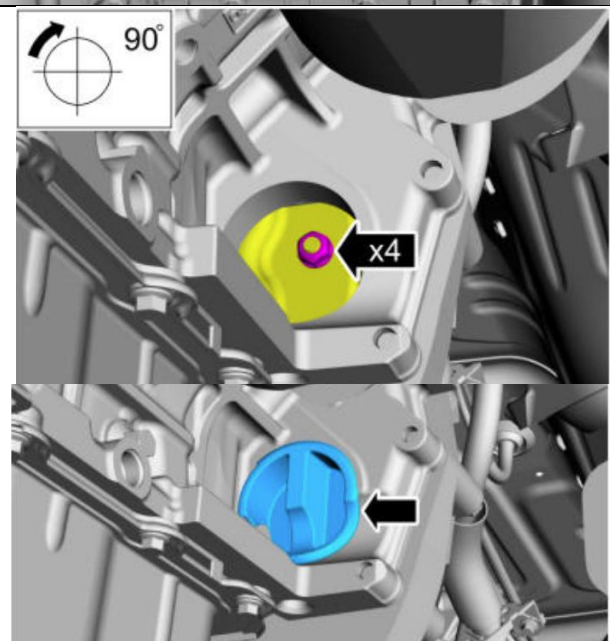

10. Connect and lock the transmission electrical connector.

Attach the wiring harness retainers to transmission.

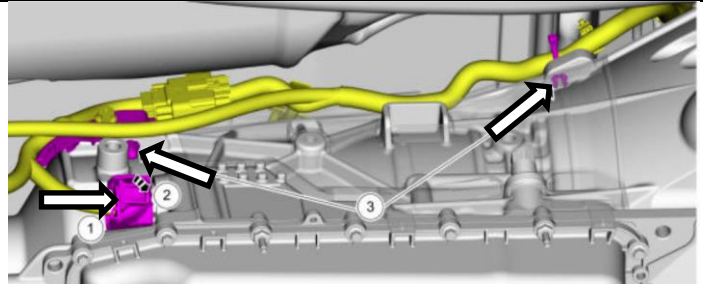

11. Place the fuel line bracket and install the bolt.

Torque: 26 lb.ft (35Nm)

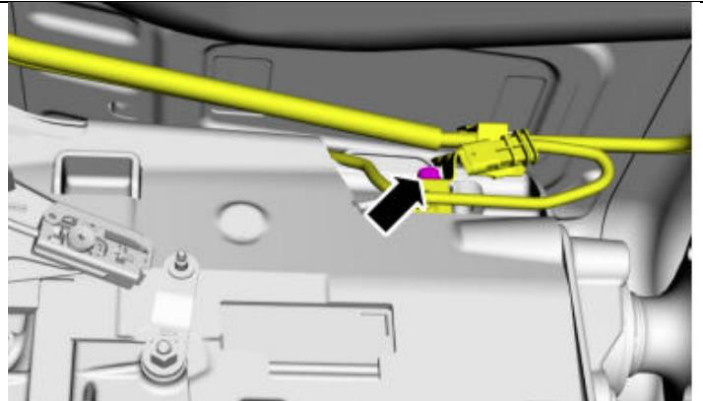

12. Place the fuel line bracket in place, install the bolt, and connect the transfer case vent tube.

Torque: 26lb.ft (35Nm)

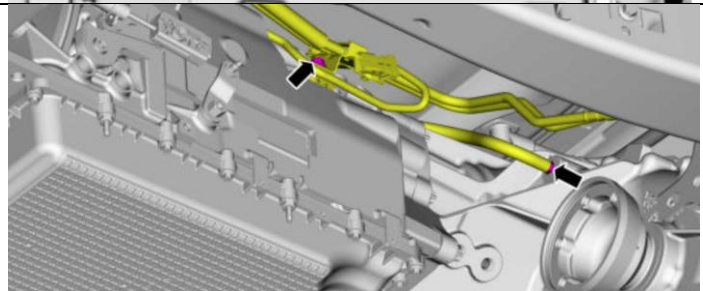

13. Connect the transfer case vent tube and the electrical connector.

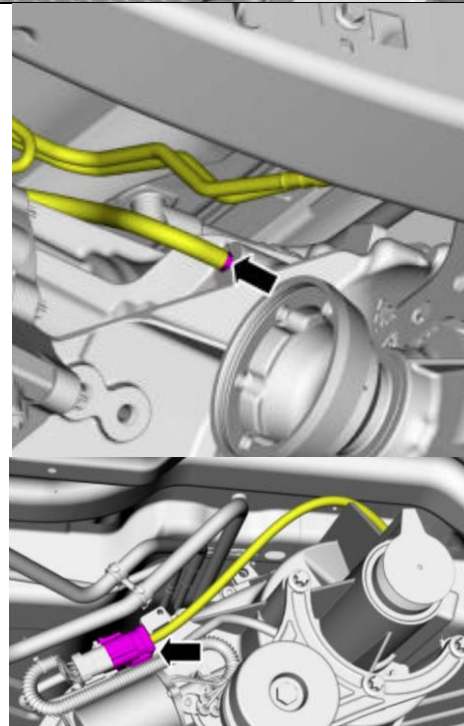

14. Install the selector lever cable bolts but keep the cable disconnected to the manual control lever.

Note:

- If equipped, install the cable splash shield and bolt.

Torque: 20lb.ft (30Nm) for both

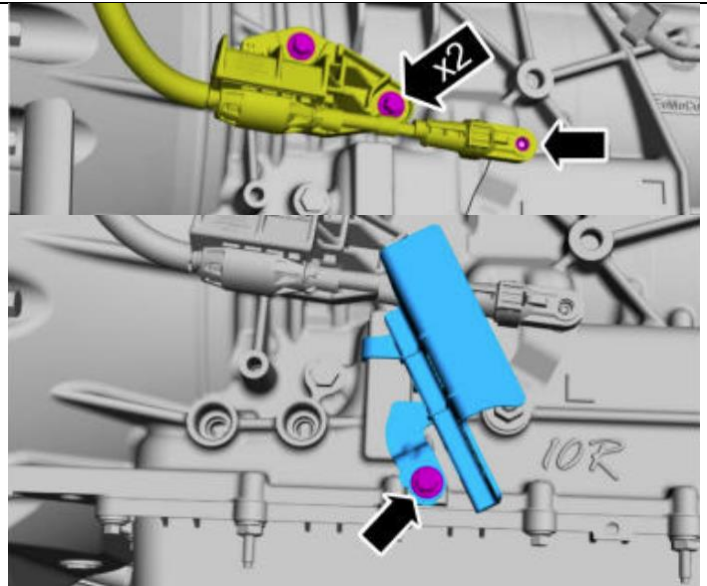

15. Position the RH catalytic converter, and hand tighten it.

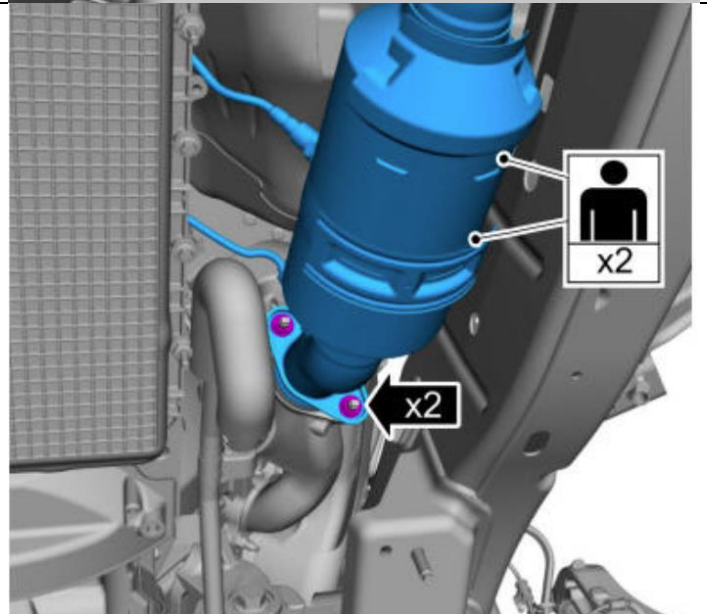

For 2WD

16. Put on the transmission support insulator.

Torque bolts in order shown.

Torque: 76 lb.ft (103Nm)

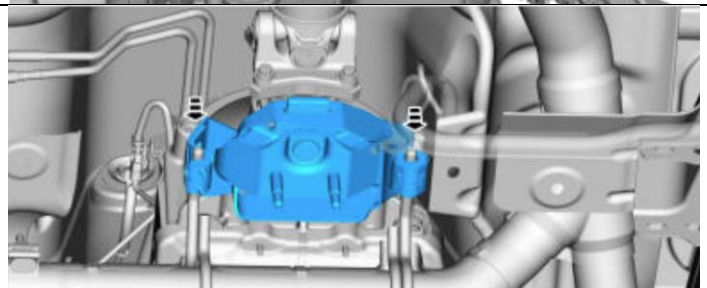

For 4WD

17. Install the transmission support insulator.

Torque bolts in order shown.

Torque: 76 lb.ft (103Nm)

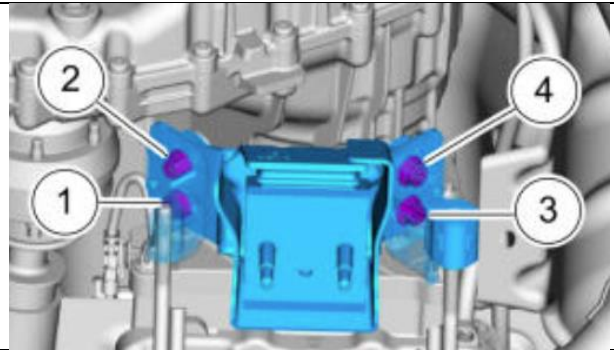

18. Install the LH isolator cap with the bolt.

Torque: 41 lb.ft (55Nm)

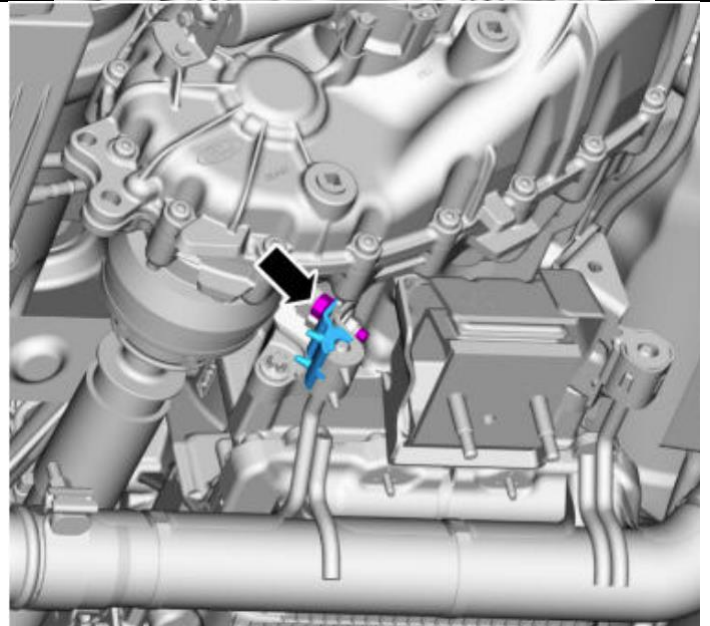

19. Install the transmission support crossmember.

Torque: 85lb ft (115Nm)

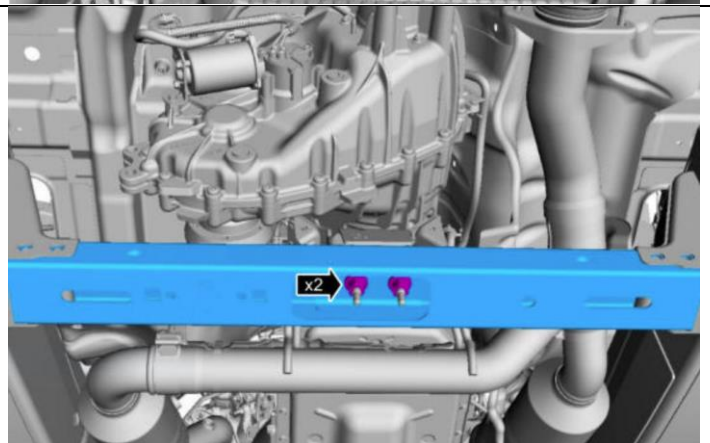

20. Install the transmission support crossmember nuts and bolts.

Torque: 76 lb ft (103Nm)

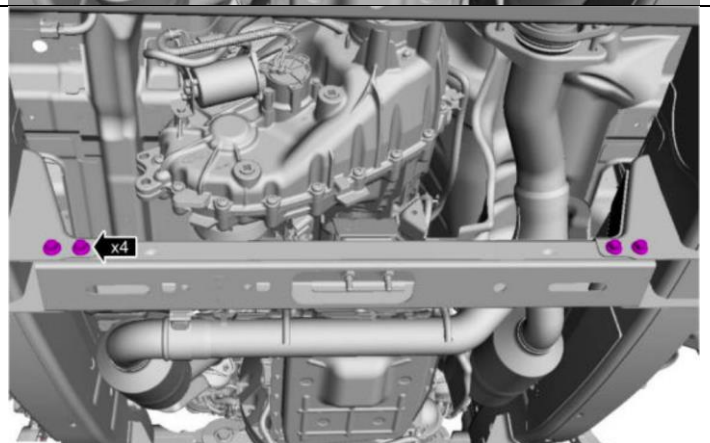

21. Install both LH and RH exhaust heat shield.

Torque: 177lb.in (20Nm)

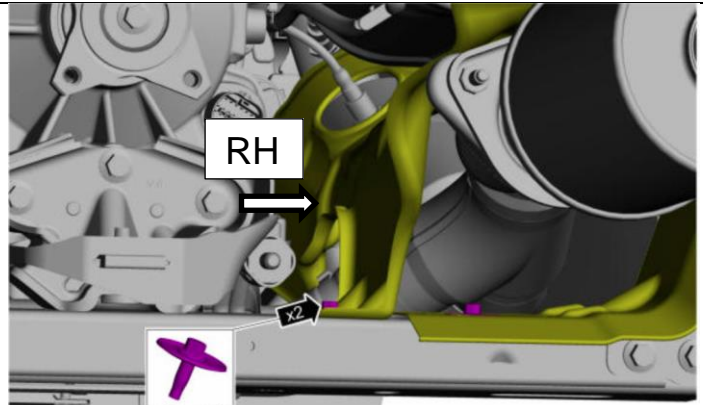

22. If equipped, install the wiring harness onto transmission crossmember.

Torque: 177in.lb (20Nm)

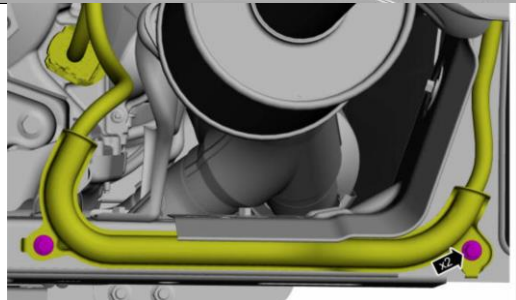

23. Install the skid plate.

Torque: 177 in.lb (20Nm)

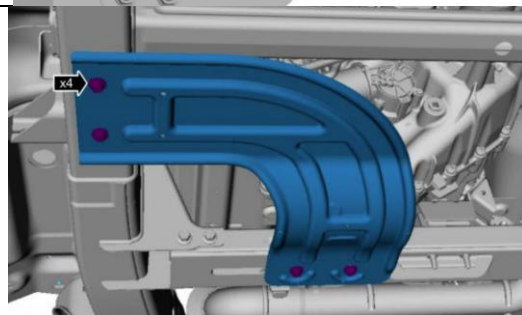

24. Position the LH catalytic converter in vehicle with a new gasket, and tighten the nuts.

Torque: 30 lb.ft (40Nm)

Then tighten clamp.

Torque: 41 lb.ft (55Nm)

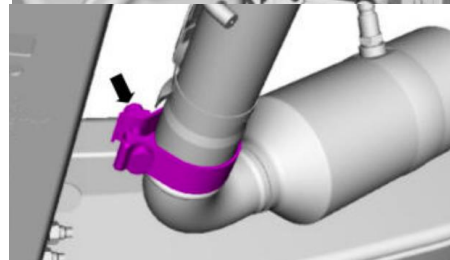
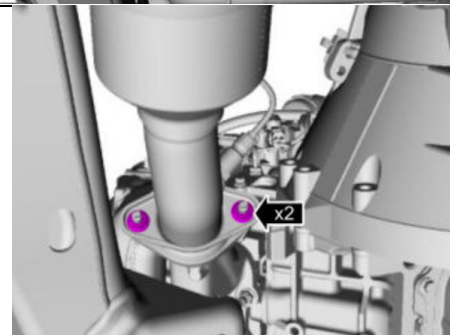

25. Connect both LH and RH HO2S electrical connector.

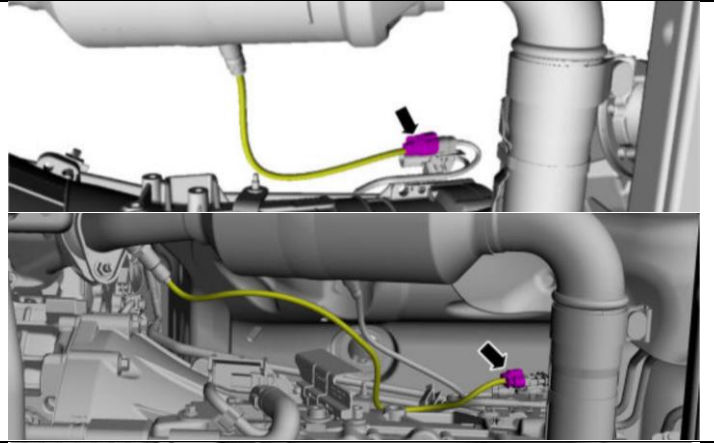

26. Tighten the RH catalytic converter nuts.

Then connect the catalyst monitor sensor.

Torque: 30 lb.ft (40Nm)

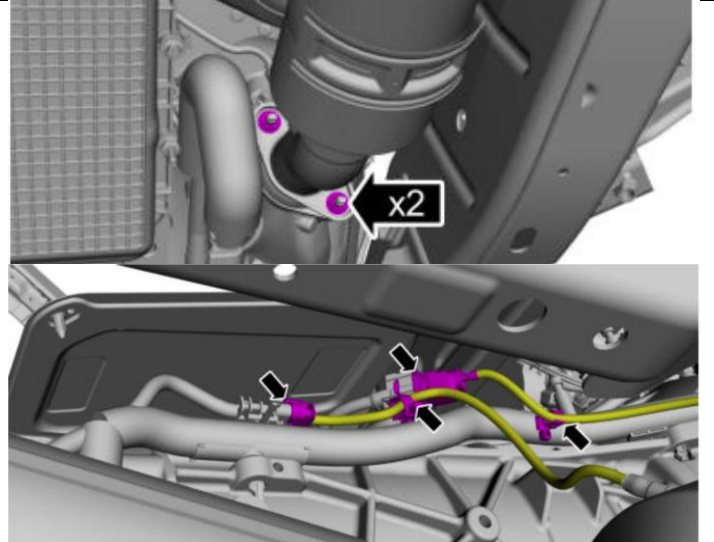

27. Install catalytic converter flange to the muffler inlet pipe bolts.

Torque: 30 lb.ft (40Nm)

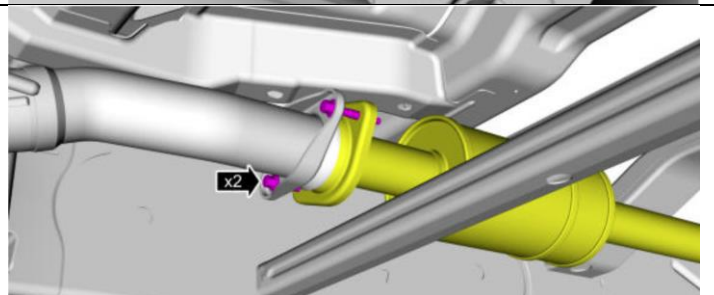

28. Install transmission fluid cooler tubes with the bolt.

Torque: 22 lb.ft (30Nm)

Note:

- Inspect the transmission fluid tube backing rings and seals for damage and replace if necessary.

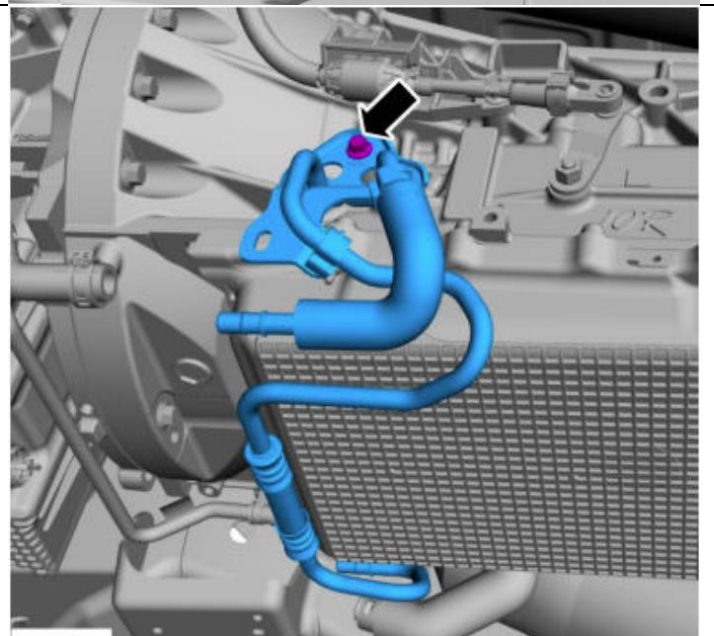

For 4WD

- 29. To install the rear driveshaft, slide the spline into the transfer case.

Next align the index line, and install the 4 bolts.

Torque: 76lb.ft (103Nm)

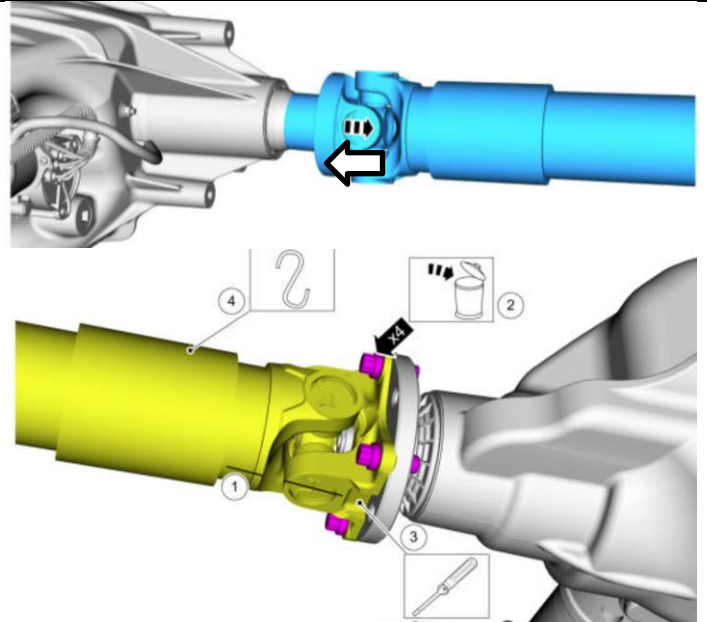

- 30. If you have a two-piece driveshaft, install the driveshaft carrier bearing bolts.

Torque: 35lb.ft (48Nm)

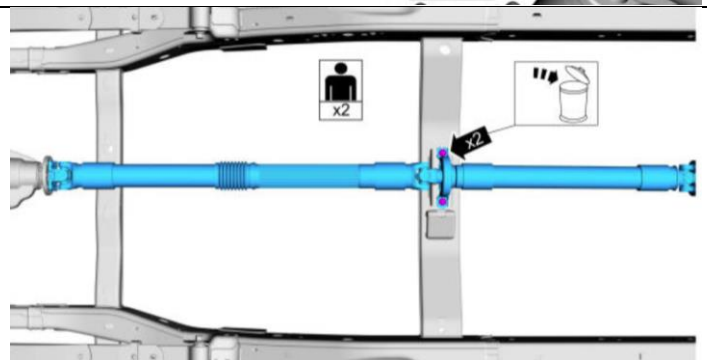

For 2WD

- 31. Align the index line and install the 4 bolts from the driveshaft flange to transmission flange.

Torque: 76lb.ft (103Nm)

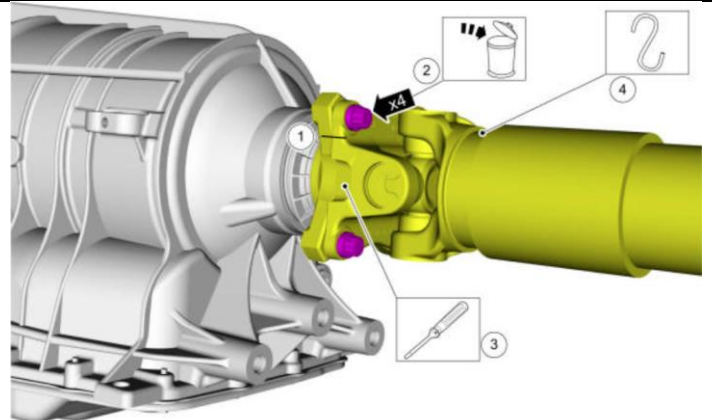

**Steps 32-36 for 4WD
Skip to 37 for 2WD**

- 32. Install the front driveshaft.

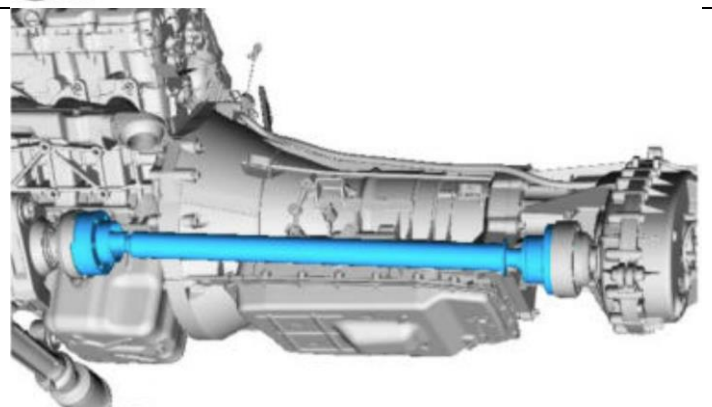

- 33. Install the rear driveshaft CV joint-to-transfer case flange cup bolts and retaining straps.

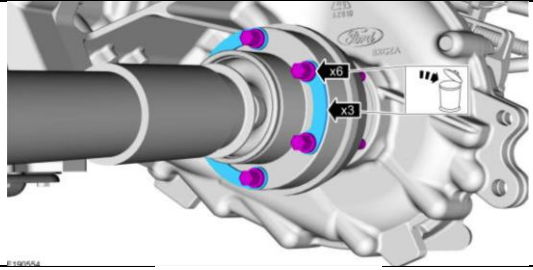

Torque: 41lb.ft (55Nm)

- 34. Ensure to check the fluid level in the transfer case.



- 35. Ensure to align the index mark and install the front driveshaft CV joint-to-pinion bolts and retaining straps.



Torque: 41lb.ft (55Nm)

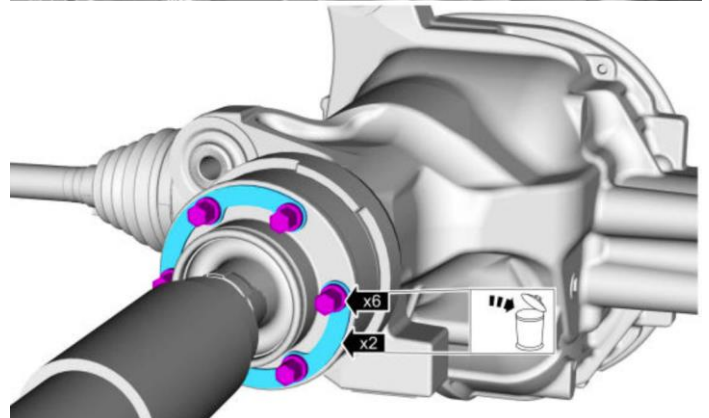

- 36. Move the stabilizer bar into position and install the bracket nuts.

Torque: 41lb.ft (55Nm)

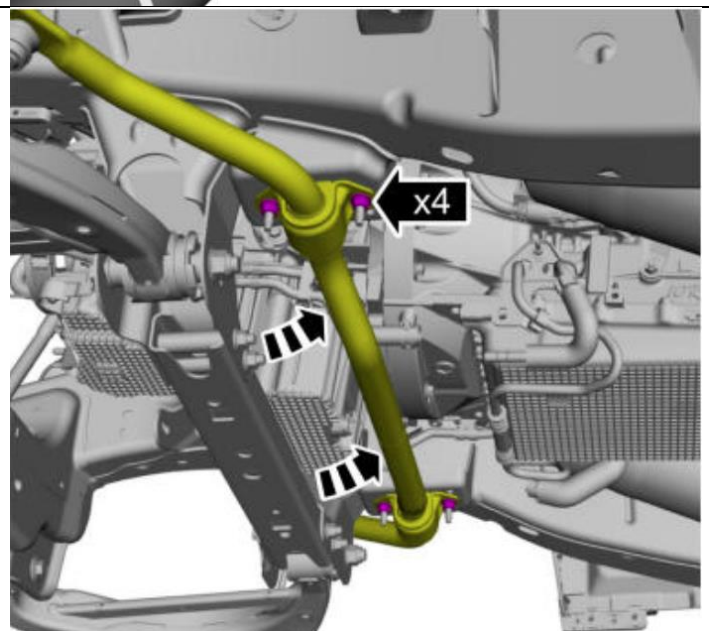

37. Install the transmission fluid cooler with the bolts and the hose clamp.

Torque: 22 lb.ft (30Nm)

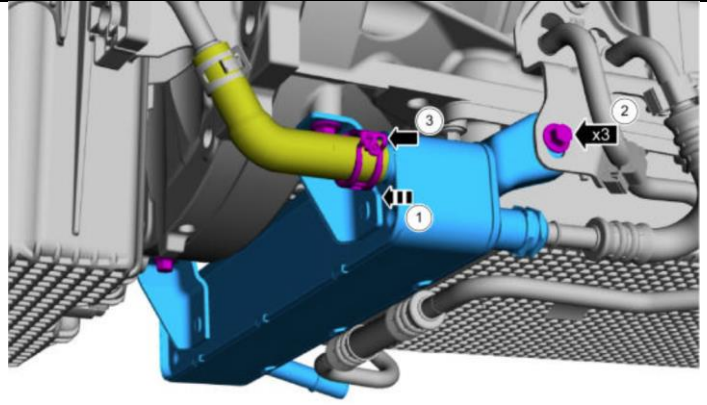

38. Connect the coolant hose to the transmission fluid cooler.

Note:

- Remove tube clamps after hose is connected.

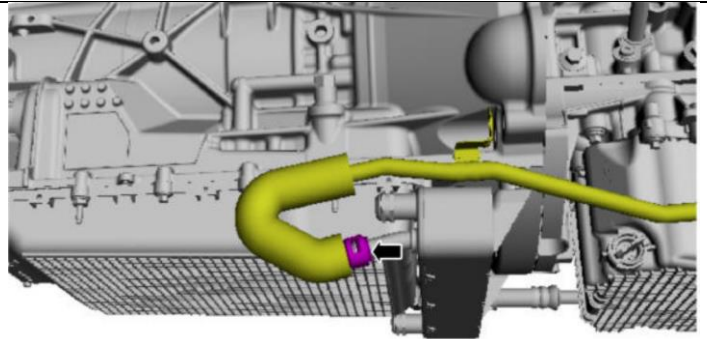

39. (1) Connect the transmission fluid cooler outlet tube and the inlet tube to the transmission fluid cooler.

(2) Install the secondary latch on both inlet and outlet tubes
Place the heat shields on both inlet and outlet side.

Note:

- Outlet side shown.

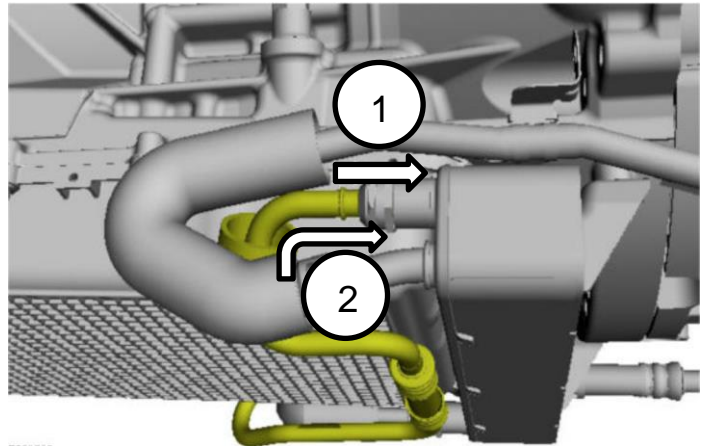

40. Install the starter motor with the three bolts.

Torque: 35lb.ft (48Nm)

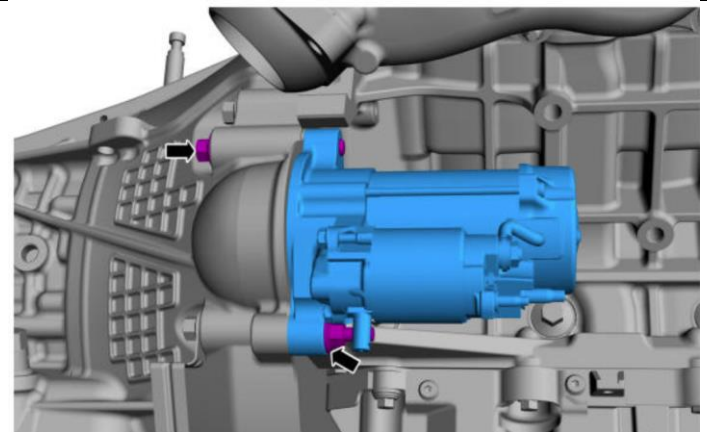

- 41. (1) Install the starter motor ground cable and secure with nut.

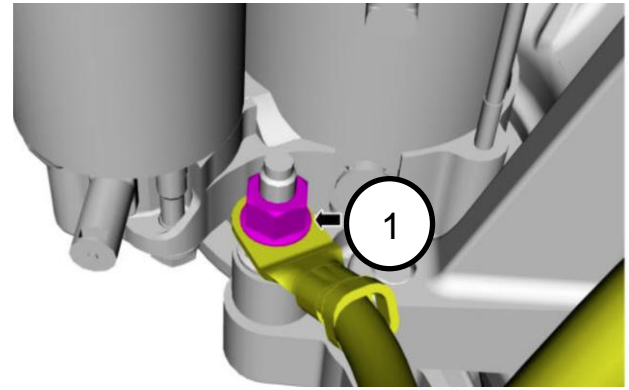

Torque: 18lb. ft (24Nm)

- (2) Install the starter motor solenoid control wire and secure with the nut.

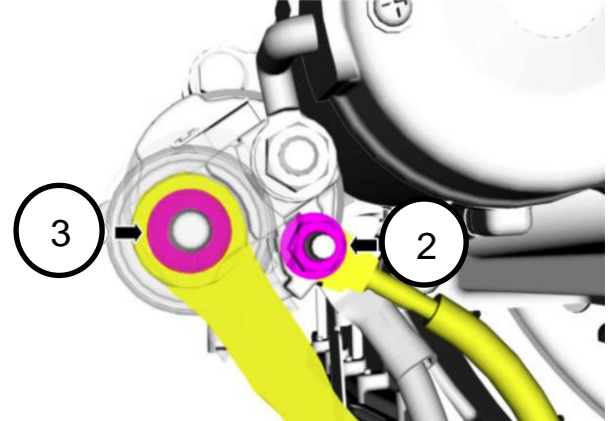

Torque: 53lb.in (6Nm)

- (3) Install the starter motor solenoid battery cable and secure with nut.

Torque: 106lb.in (12Nm)

Close the starter motor solenoid battery cable cover.

- 42. Install the skid plate and underbody shield.

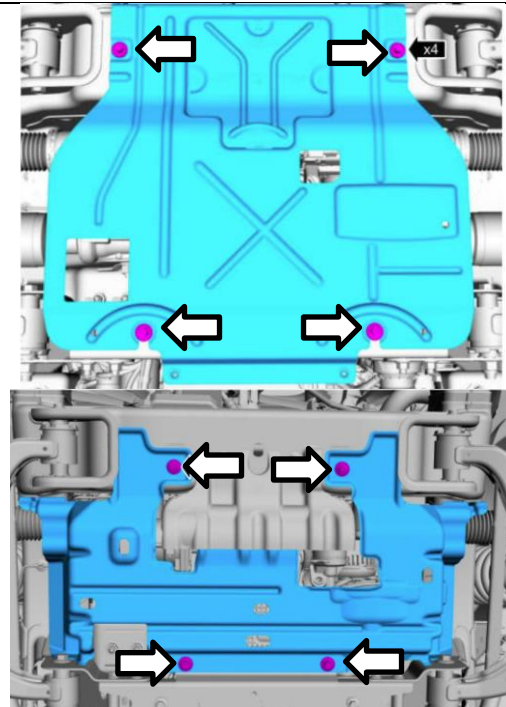

Torque: 30lb. ft (40Nm)

- 43. Reconnect the battery.

- 44. On a hoist, position the lever in “Drive” position.

Rotate the manual lever (located on the transmission) clockwise until it stops.

Then rotate it counterclockwise 3 positions.

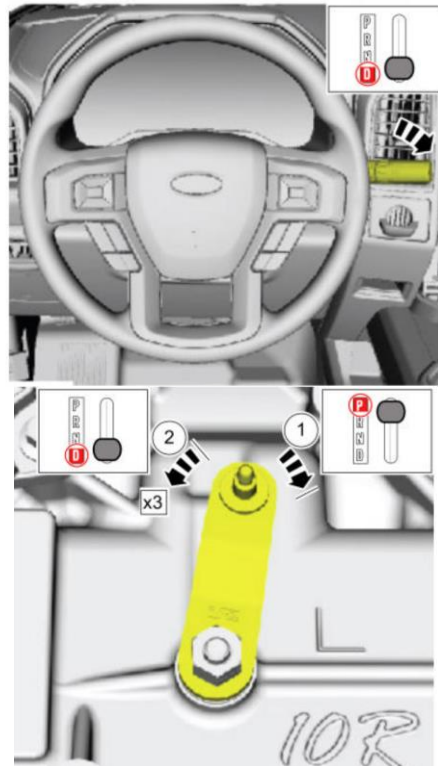

- 45. Connect the selector lever cable to the manual control lever, and lock it on.

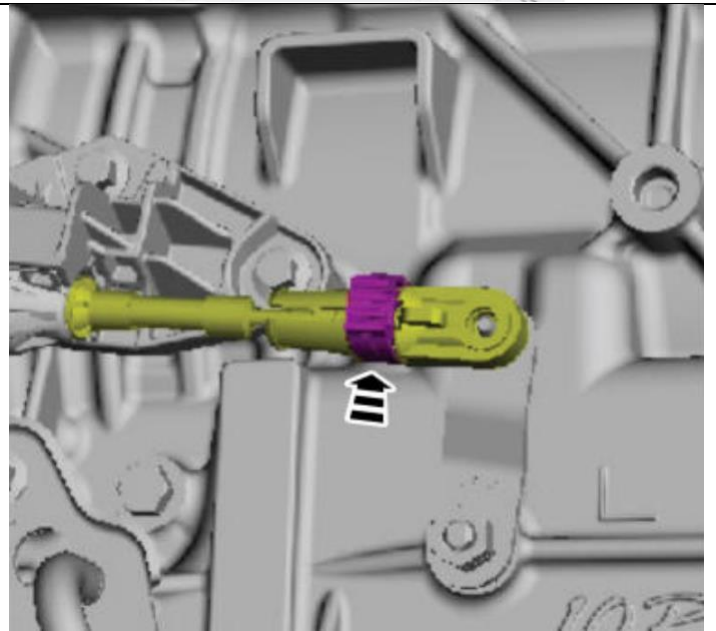

- 46. With the new 12-digit solenoid body identification # (1) and 13-digit solenoid body strategy # (2) and a scan tool, download the correct strategy file.

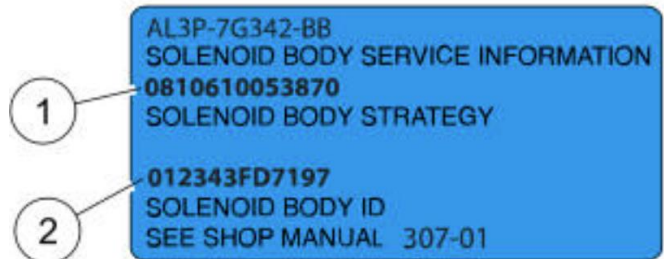

- 47. After turning the engine on, go into each gear for about 5 seconds, and confirm the fluid level is in the correct range and is in the correct operating temperature level.

Note:

Stock transmission will take 13 quarts to fill up from being dry.

- For pan without BD logo, will need about 14.9 quarts
- For pan with BD logo, will need about 15.1 quarts
- Fluid is XT-12-QULV

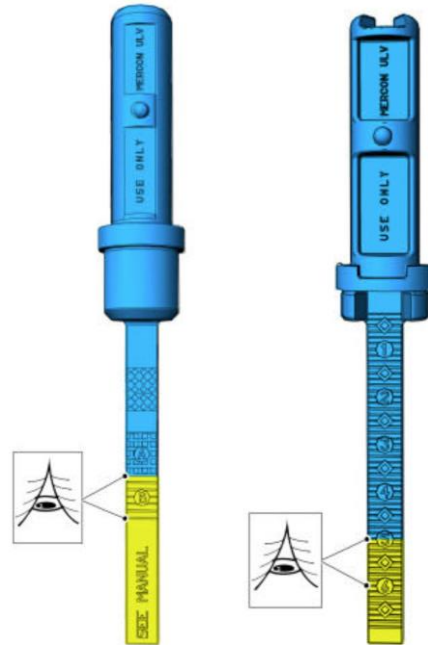

- 48. Install the oil pan heat shields.

Torque: 80lb.in (9Nm)

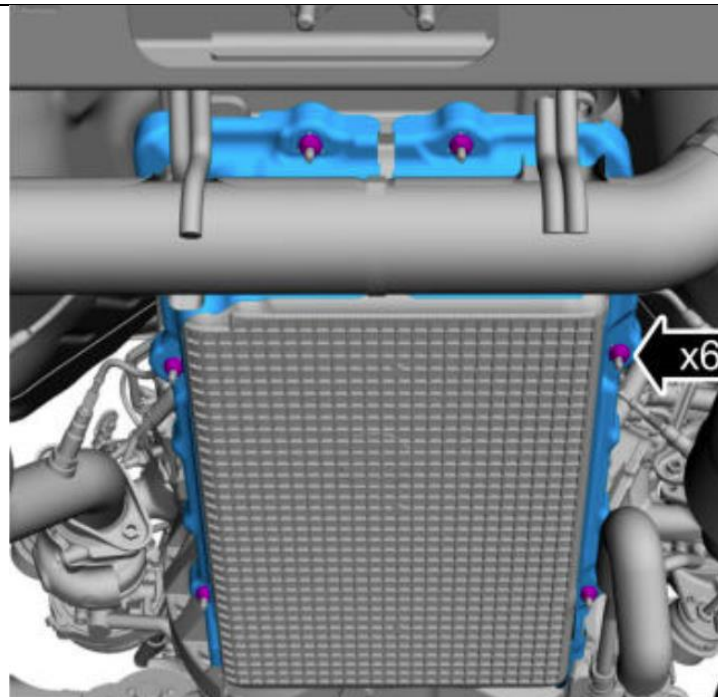

- 49. Install the splash shield.

Torque: 71lb.in (8Nm)

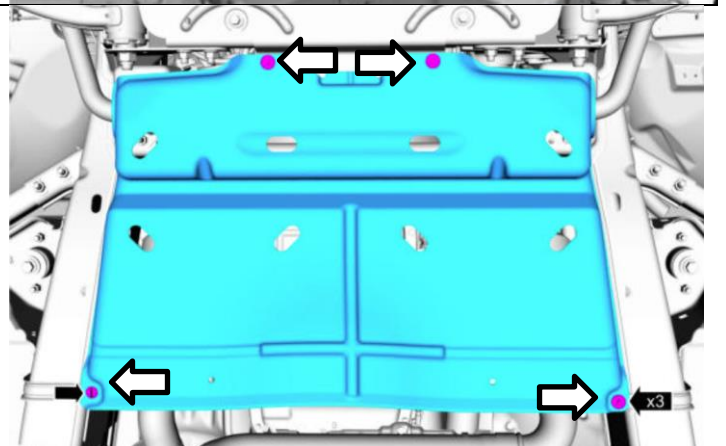

Line Pressure Checks

With upgrades done to the valvebody, we want to make sure that your transmission is functioning properly. To check your mainline pressure, connect a gauge to the pressure port on the side of the transmission

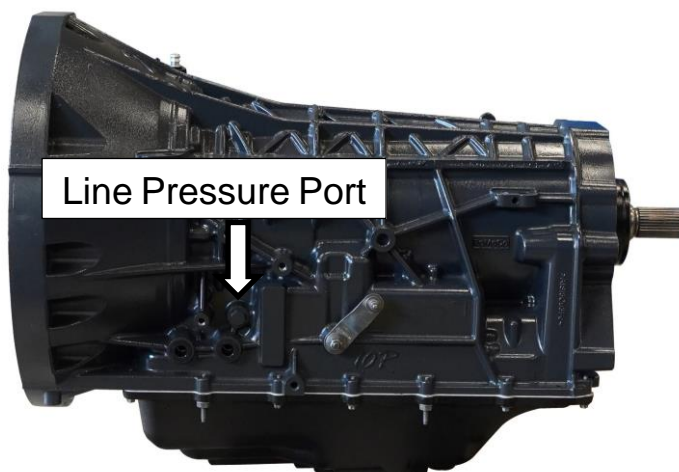

The line pressure service port plug thread is M10x1.00NPT.

(Psi) +/-15psi	OEM 10R80		BD 10R80 RoadMaster	
	No Throttle	WOT	No Throttle	WOT
Park	90	-	120	-
Neutral	90	-	120	-
Reverse	90	-	120	-
1	65	230	110	260
2	65	165	110	200
3	65	230	110	260
4	65	130	110	180
5	75	140	120	180
6	75	140	120	180
7	75	230	120	260
8	75	140	120	230
9	75	150	120	180
10	70	150	120	180