



Windshield Header Installation Instructions

BESTOP

For: Ford Bronco 1966 - 1977

Part Number: 51206



WARNING

This product is designed to enhance the appearance of the vehicle and to shield the occupants from ordinary weather conditions. Do not rely in any way on the components of this product to contain occupants within the vehicle, or to protect against injury or death in the event of an accident. This product will not protect the occupants from falling objects. Never operate vehicle in excess of manufacturer's specifications.

WEAR SEAT BELTS AT ALL TIMES

Read and follow, precisely, all installation instructions provided when installing this product. Failure to do so may result in a poor fit and could place occupants of the vehicle in a potentially dangerous situation. Failure to properly install or reinstall this product may cause the top or a component part to come off the vehicle, potentially causing an accident and possible injury to the occupants of the vehicle. After installing or reinstalling the top, check to make sure it has been properly installed.

Installation Tips

Before you begin installing this windshield header, read all instructions thoroughly. After completing the installation, keep these instructions for further reference.

Parts List and Hardware Identification



Windshield Header -
Driver's Side, Qty - 1

Windshield Header -
Passenger Side, Qty - 1

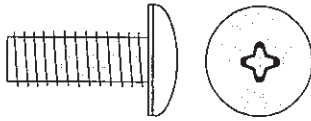

1/4-20 x 3/4" Pan Head Bolt,
Qty - 8, Part Number 257.92

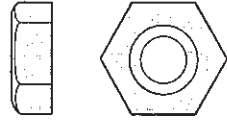

1/4-20 Hex Lock Nut, Qty - 8,
Part Number 198.26

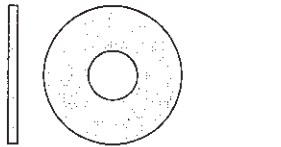

1/4" x 3/4" OD Washer, Qty - 16,
Part Number 257.93

Tools Needed

Adjustable Wrench
Phillips Screw Driver
Safety Glasses

Windshield Adjustment

Step One

Check Windshield Adjustment

Measure from the inside edge of the windshield frame to the inside edge of the tailgate. This measurement should be 83-3/4" - 84" or the top will not fit or function properly. If the measurement is slightly more than 84" the tension from the top may pull it into position. If the measurement is less than 83-3/4", loosen the bolts on both sides of the windshield frame, place shims under the frame and re-tighten the bolts.

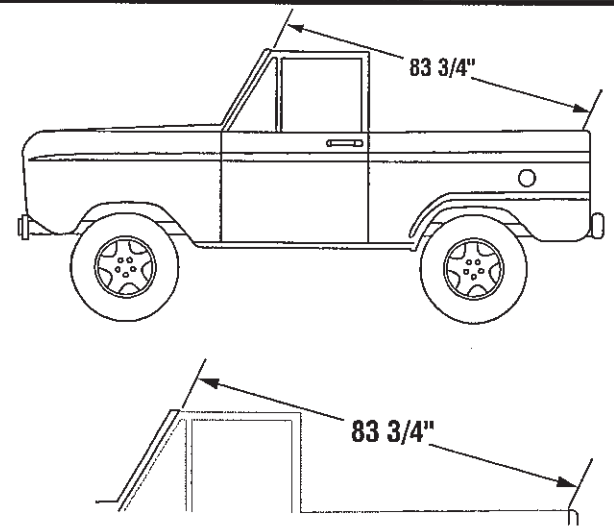

Hardware Installation

Step One

Install Windshield Adapter

Orient the two pieces of the Windshield Adapter on the windshield frame with the curve toward the outside of the vehicle and the lip toward the front. Align the holes in the adapter with the holes in the frame. Install a 1/4-20 x 3/4" Pan Head Bolt, a 1/4-20 Hex Lock Nut and (2) 1/4 x 3/4 OD Flat Washers in each hole.

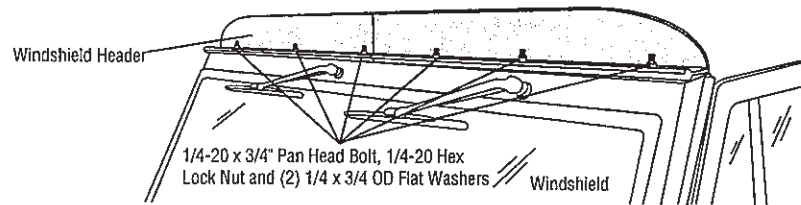

Note: If there is any weatherstripping along the top of the windshield frame it should be removed.

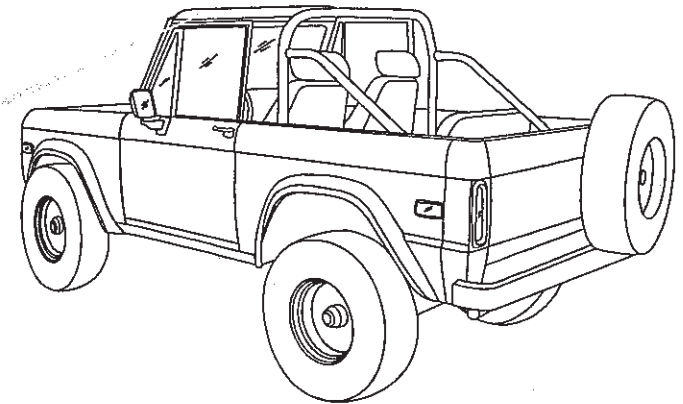

Step Two

If Windshield Wiper Motor Cover interferes with Adapter Installation

If your vehicle has a plastic windshield wiper motor cover that interferes with the installation of the Windshield Adapter you will need to trim the sides of the cover. Remove the cover and use the templates provided to mark the areas to be trimmed. Reinstall the cover.

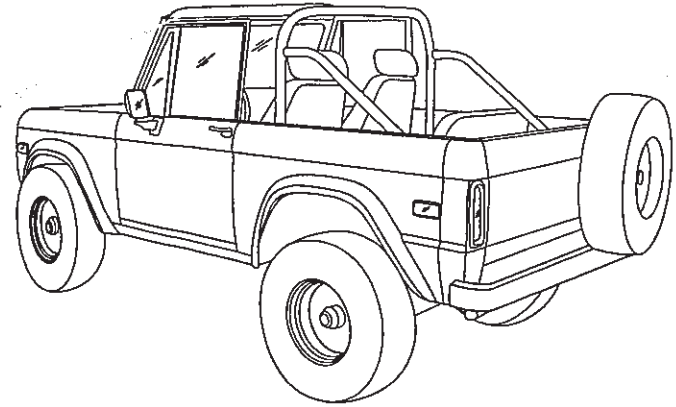
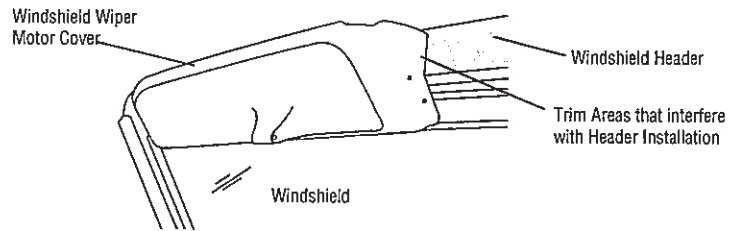

Templates for Windshield Wiper Motor Cover

Cut out the template and position it on the wiper motor cover. Mark the cover along the straight edge of the template. Cut the cover along the line.

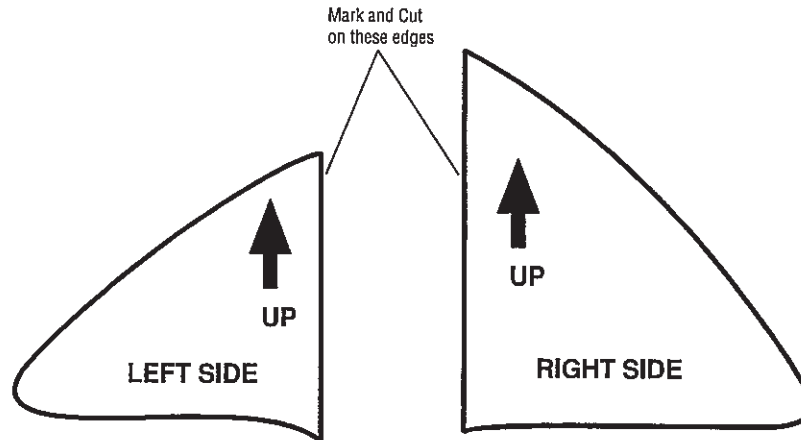

For Bestop Warranty Information, Please go to;
<https://www.bestop.com/help/warranty-information/>

