



Installation Instructions



Supertop®









Includes 2-Piece Soft Doors

Vehicle Application

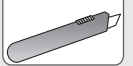
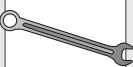
- Jeep CJ5
1976 – 1983
Part Number: 51597

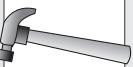
www.Bestop.com - We're here to help! Visit our web site and click on ["Ask a Question"](#). Click here for more [Jeep Accessories by Bestop](#).

INSTALLATION TIME	SKILL LEVEL
 <p>3 Hours</p>	 <p>3 - Moderately Difficult</p>

TOOLS			
 Power Drill 1/8", 3/32", 7/32" and 3/8"	 Center Punch	 Adjustable Wrench	 Utility Knife
 Wrench 7/16"	 Phillips Screwdriver	 Flat-Head Screwdriver	 Hammer
 Pencil	 Tape Measure 10'	 Safety Glasses	



	CAUTION Safety glasses should be worn at all times while installing this product.
---	--

Installation Tips

Before you begin installing this assembly, read all instructions thoroughly.

For a smooth fit:

For ease in installation, the product should be installed at temperatures above 72° F. Below this temperature, the fabric may contract an inch or more, making it difficult to fit to the vehicle. It is normal for fabric to contract and wrinkle when stored in the shipping carton. Within a few days after the installation, the fabric will relax and the wrinkles will disappear.

! WARNING This product is designed primarily to enhance the appearance of the vehicle and to shield the occupants from ordinary weather conditions. Do not rely in any way on the components of this product to contain occupants within the vehicle, or to protect against injury or death in the event of an accident. This product will not protect the occupants from falling objects. Never operate the vehicle in excess of manufacturer's specifications.

WEAR SEAT BELTS AT ALL TIMES

Read and follow, precisely, all installation instructions provided when installing product. Failure to do so may result in a poor fit and could place occupants of the vehicle in a potentially dangerous situation.

Supertop® – Installation Instructions

Top Fabric	Qty - 1
Quarter Window, Right	Qty - 1
Quarter Window, Left	Qty - 1
Rear Window	Qty - 1
Door, Upper - Right	Qty - 1
Door, Upper - Left	Qty - 1
Door, Lower - Right	Qty - 1
Door, Lower - Left	Qty - 1

Parts List and Hardware Identification

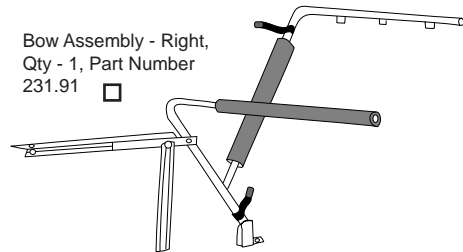

Windshield Retainer - Right, Qty - 1, Part Number 225.42

Bow Assembly - Left, Qty - 1, Part Number 231.92

Windshield Retainer - Left, Qty - 1, Part Number 225.43

Vertical Retainer Mount, Left, Qty - 1, Part Number 207.30

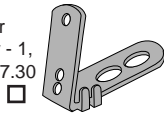

Vertical Retainer Mount, Right, Qty - 1, Part Number 207.29



Paddle Handle Assembly, Qty - 2, Part Number 245.46

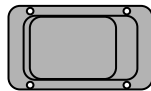

Front Door Strike - Left, Qty - 1, Part Number 223.49

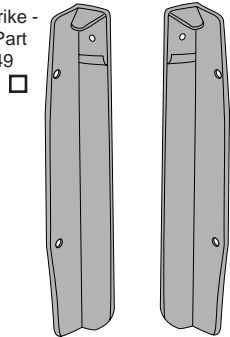

Door Striker - Right, Qty - 1, Part Number 212.87

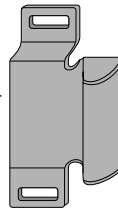

Door Striker - Left, Qty - 1, Part Number 212.88

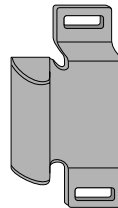

Front Door Strike - Right, Qty - 1, Part Number 223.48

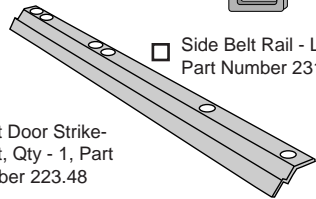

Side Belt Rail - Left, Qty - 1, Part Number 231.86

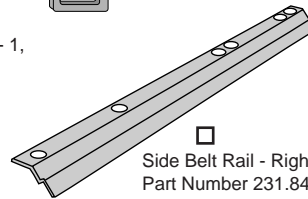

Side Belt Rail - Right, Qty - 1, Part Number 231.84

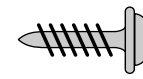

#8 x 1/2" Pan Head Washer Screw - Black, Qty - 15, Part Number 200.48

#10-24 Truss Head Machine Screw - Black, Qty - 16, Part Number 195.92

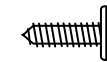
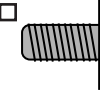

#6 x 3/8" Sheet Metal Screw, Qty - 5, Part Number 9.69

#10-24 Locknut, Qty - 16, Part Number 195.93

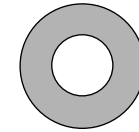

5/16" Black Washer, Qty - 18, Part Number 233.04

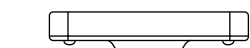
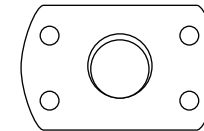

5/16-18 Tapping Plate, Qty - 18, Part Number 200.50

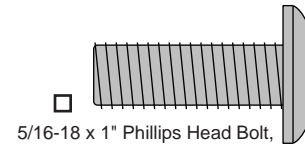

5/16-18 x 1" Phillips Head Bolt, Qty - 18, Part Number 236.20

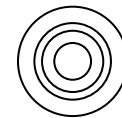
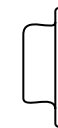
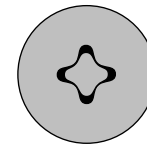

Snap Stud, Qty - 5, Part Number 9.68

Because of Generic Packaging, extra parts may be included.

Tailgate Retainer, Qty - 1, Part Number 233.44

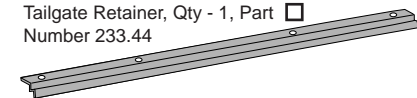

Supertop® – Installation Instructions



WARNING

Improper windshield adjustment will result in poor fitting top and

doors, causing looseness or undue strain on the top.

Windshield Measurement

Before installing the top, check the windshield measurement. The distance from the top lip of the windshield to the top outer edge of the body must be 67 1/2" on both sides of the vehicle. Measure from 6" inside the doors.

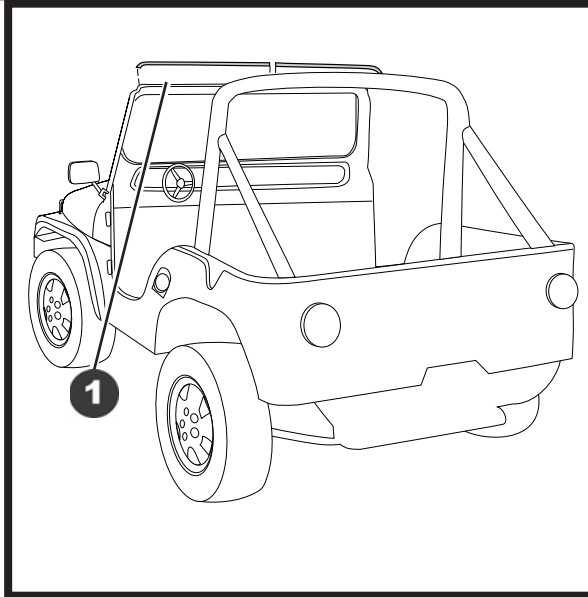
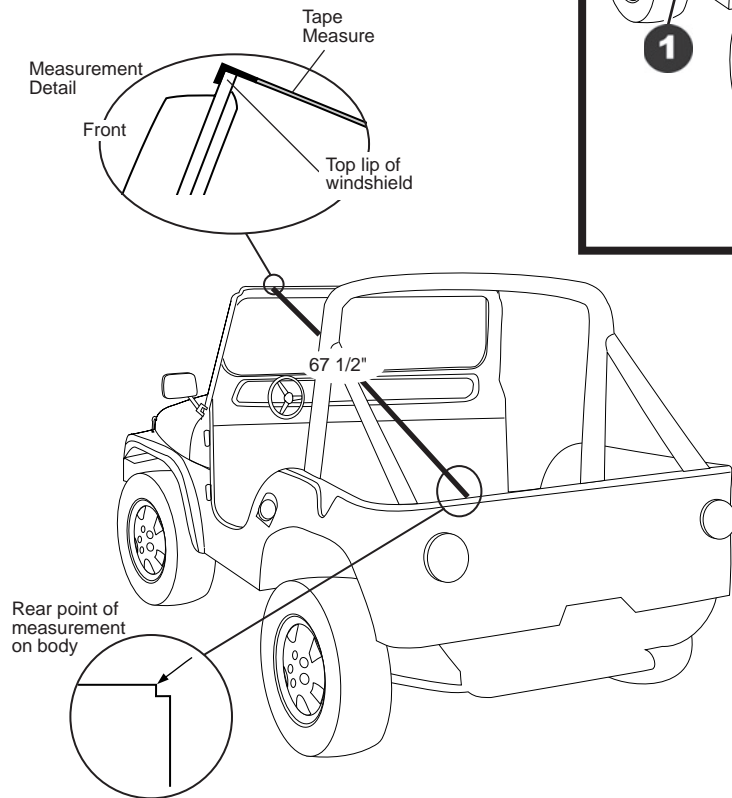

CJ5 Windshield Adjustment: If necessary, adjust your windshield by loosening the two screws in the Windshield Clamps located at the base of the windshield on each side of the vehicle. You may then lean the windshield forward or back as necessary. Use a shim to fix the windshield in place if it remains loose after you tighten the screws.

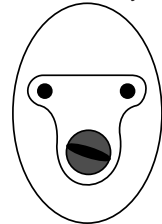

Windshield Clamp Detail

Loosen the two screws in bracket and lean the windshield forward or back to adjust. You may have to place a shim between the windshield and the body.



WARNING

A loose Windshield Retainer may allow the top to disengage from the windshield, causing damage to the top and possible injury to the occupants of the vehicle.

Make certain that the Windshield Retainer is securely fastened to the windshield during installation and at all other times by checking the tightness of the mounting screws every three months.

Do not use any drill size other than 1/8". Failure to use the correct size may cause the Windshield Retainer to loosen.

1 Install Windshield Retainer

Position the two piece Windshield Retainer on top of windshield frame. Use retainer pieces as templates to mark, center punch and drill eleven 1/8" holes. Install with eleven #8 x 1/2" Pan Head Screws.

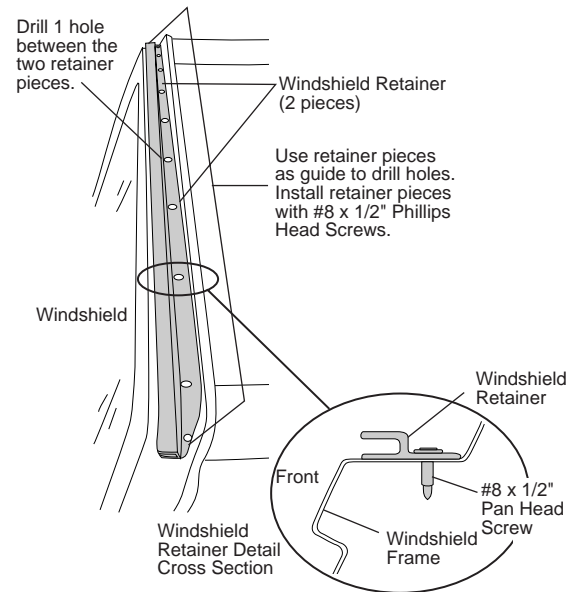

Supertop® – Installation Instructions

CAUTION When drilling in the top edge of the vehicle body, check underneath for wiring for the rear lights. Pull the wiring out of the way before drilling.

2 Install Rear Corner Belt Rails

Install the Left and Right Rear Corner Belt Rails on each side of the vehicle. Use the Corner Belt Rails as templates to mark, center punch and drill three 3/8" holes in the top edge of the vehicle body. Install the Corner Belt Rails with three 5/16" Phillips Head Bolts, three 5/16" Washers and three 5/16" Tapping Plates. **Do not tighten the bolts yet.**

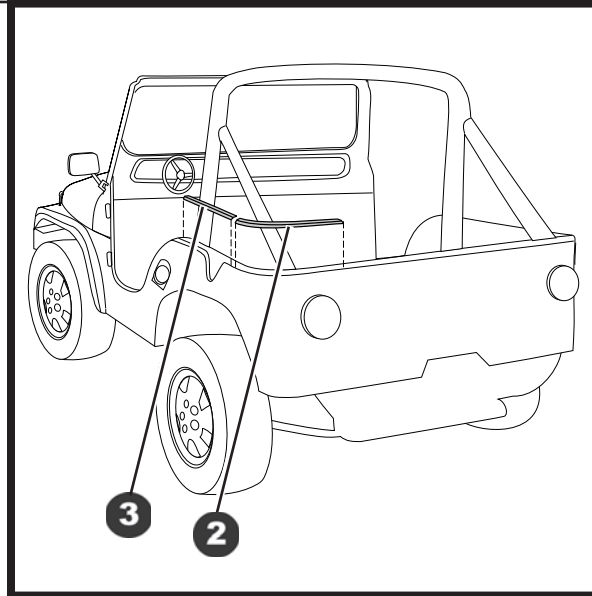
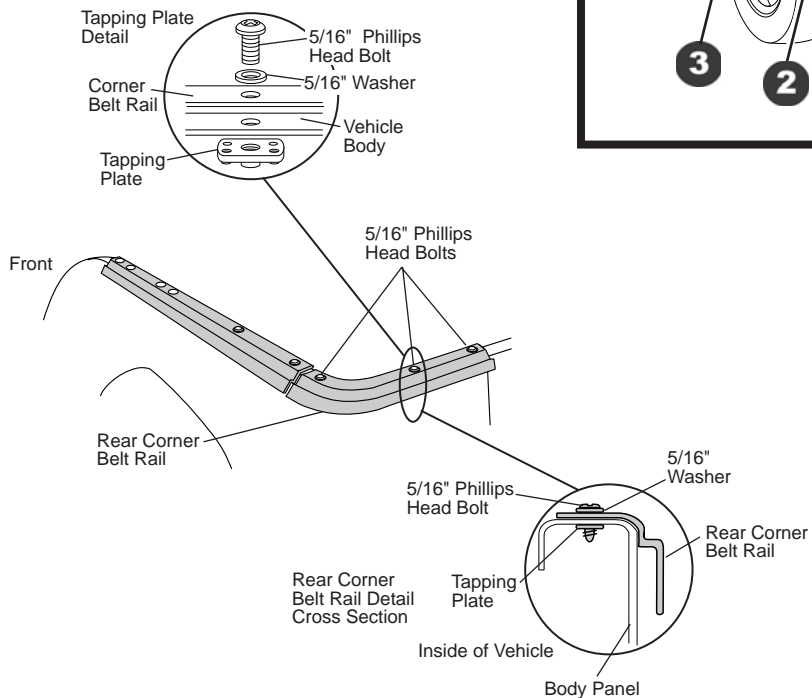

CAUTION When drilling in the top edge of the vehicle body, check underneath for wiring for the rear lights. Pull the wiring out of the way before drilling.

3 Install Side Belt Rails

Install the Left and Right Side Belt Rails on each side of the vehicle. Use the Belt Rails as templates to mark, center punch and drill six 3/8" holes along the top edge of the body on each side of the vehicle. Secure the two rear holes in the rails with two 5/16" Phillips Head Bolts, two 5/16" Washers and two 5/16" Tapping Plates. Do not tighten the bolts yet.

NOTE There may be a small gap of +/- 1/4" between the Corner Belt Rails and the Side Belt Rails.

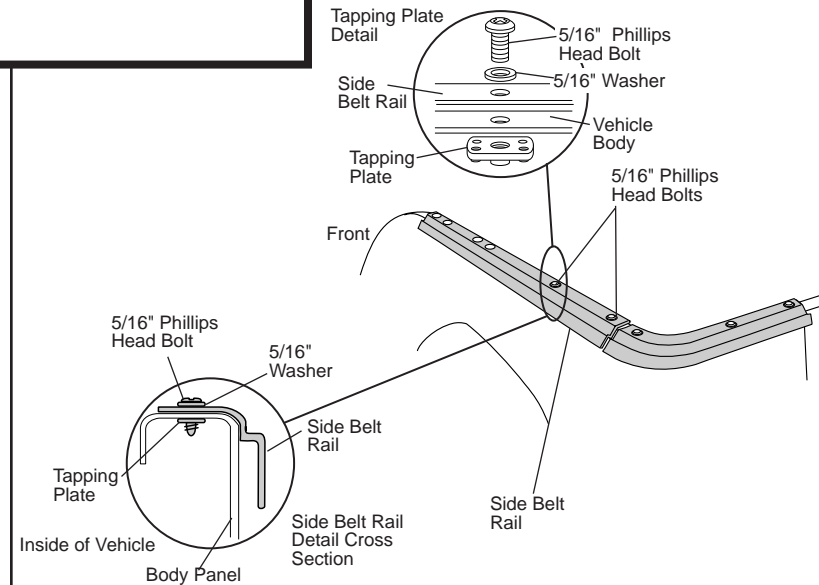

Supertop® – Installation Instructions

4 Install Tailgate Belt Rails

On non-tailgate vehicles install the Tailgate Belt Rail on top of the body, between the Corner Belt Rails. Use the Belt Rail as a template to mark, center punch and drill a 1/8" hole at each hole location on the Belt Rail. Install the Belt Rail with four #8 x 1/2" Pan Head Washer Screws.

If the vehicle has a tailgate, disregard the Tailgate Belt Rail installation. Snaps will be used once the Top Fabric has been installed.

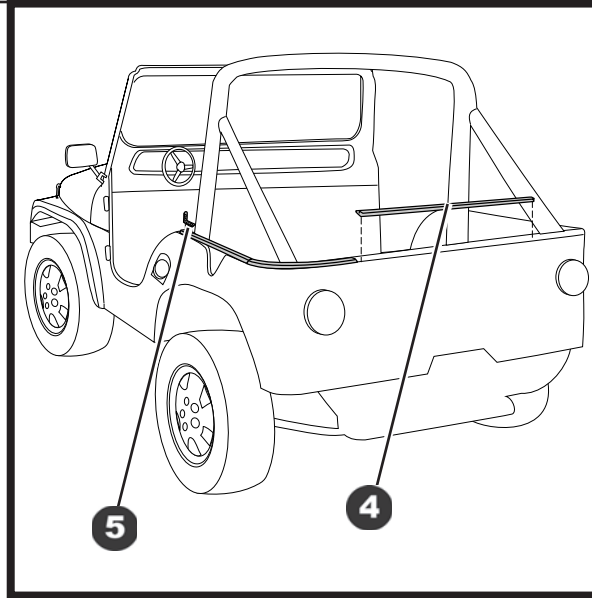
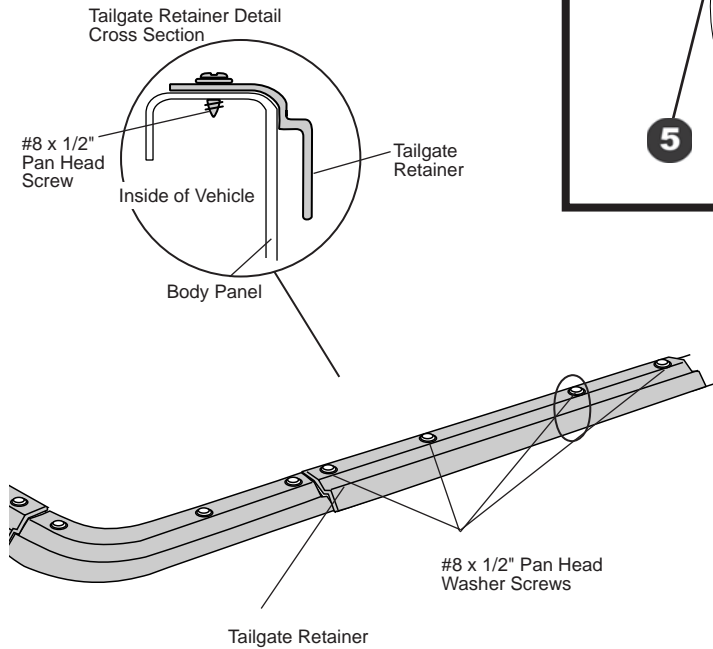

5 Install Vertical Retainer Mounts

Install the Left and Right Vertical Retainer Mounts on each side of the vehicle, just behind the door openings. Place the Vertical Retainer Mounts over the front two holes in the Side Belt Rail with the two pins toward the outside of the vehicle. Secure them with two 5/16" Phillips Head Bolts, two 5/16" Washers and two 5/16" Tapping Plates. Do not tighten the bolts yet.

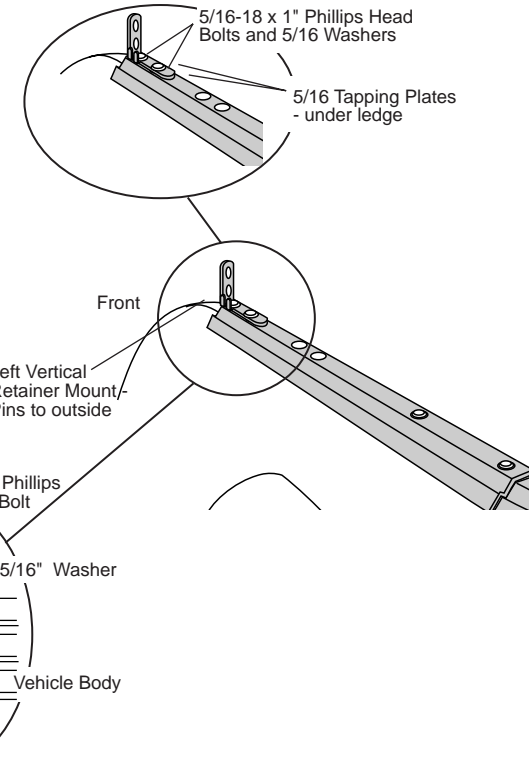

Supertop® – Installation Instructions

6 Install Door Strikers

Orient the Door Strikers with the raised edge toward the top and with the flat face toward the inside of the vehicle. Install the Door Striker on the Vertical Retainer Mount with two #10-24 Truss Head Machine Screws and two #10-24 Locknuts. Once the door is installed, the Door Striker may be adjusted in or out until you are satisfied with the way the door shuts and opens. Repeat on both sides of the vehicle.

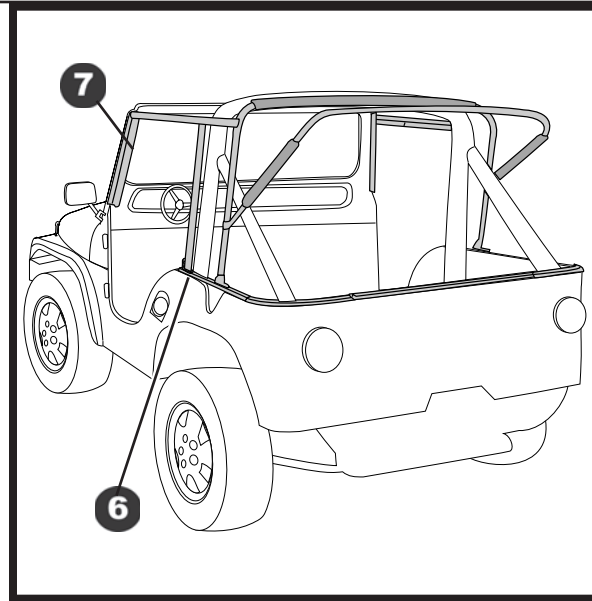
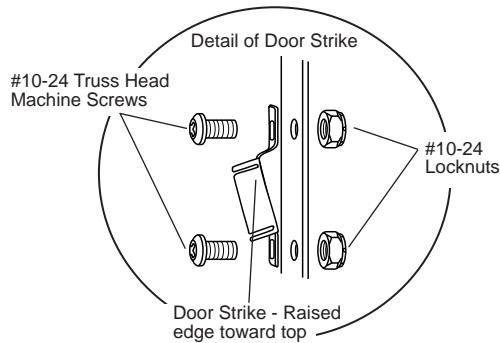
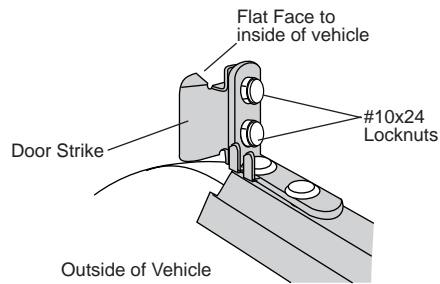

7 Install Front Door Strikes

Install the Left and Right Front Door Strikes on the inside of the windshield frame. Mount the Front Door Strike flush with the bottom, outside of the frame as shown. Use the Front Door Strike as a template to mark, center punch and drill two 7/32" holes in the windshield frame. Install the Front Door Strike two #10-24 Truss Head Machine Screws and two #10-24 Locknuts.

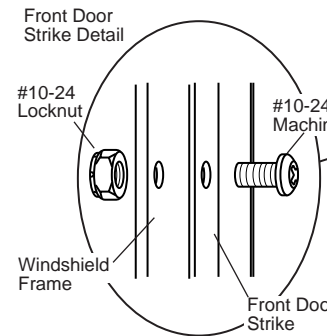
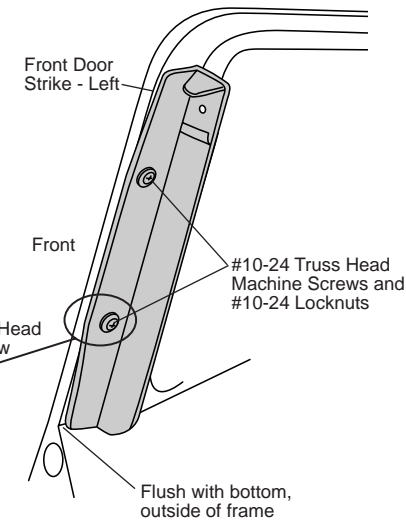

Supertop® – Installation Instructions

8 Install Bow Assembly

Lay the bow halves on top of the body with the holes in the Bow Mounts over the third and fourth holes in the Side Belt Rails.

It is important that the white packaging tape remain on the bow assemblies until the forward bolt is tightened on both sides.

Secure the FRONT hole in the Bow Mount with a 5/16-18 x 1" Phillips Head Bolt, a 5/16" Washer and a 5/16" Tapping Plate. Once the front hole is secure, cut the packing tape.

Start the male end of the Top (Front) Bow into the female end. Push forward on the bow until the two sides snap together. Slide the foam pieces on the bow together.

Once the Bow Mounts are secure, tighten all of the bolts on the Belt Rails.

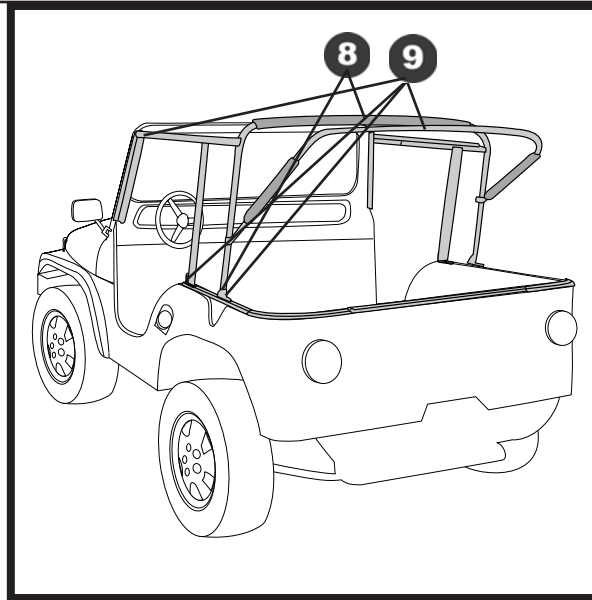

9 Install Bow Assembly

Lift the Top (Front) Bow and start the male end of the Bottom (Rear) Bow into the female end. Push forward on the bow until the two sides snap together.

Slide the Bottom (Rear) Bow up on the Top (Front) Bow to access the rear bolt position in the Bow Mount. Install and tighten the rear bolt in the Bow Mount on both sides of the vehicle.

Raise the Top (Front) Bow Assembly, holding the flat rods in an upright position, and slip the Vertical Rods over the pins on the Vertical Retainer Mounts. Slide the Horizontal Rod Assembly toward the Front Door Strike. Start at the bottom of the Horizontal Rod Assembly and roll the Assembly up until it snaps into place.

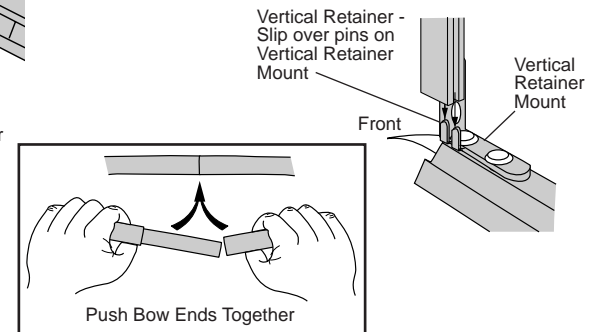
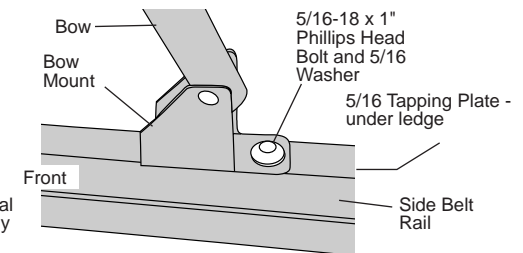
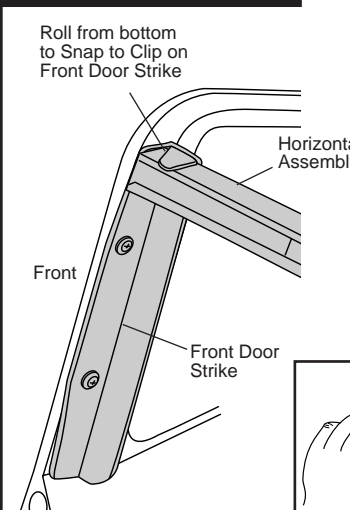
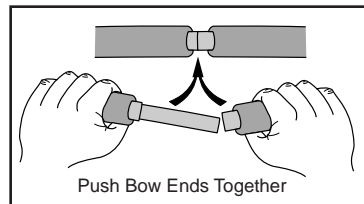
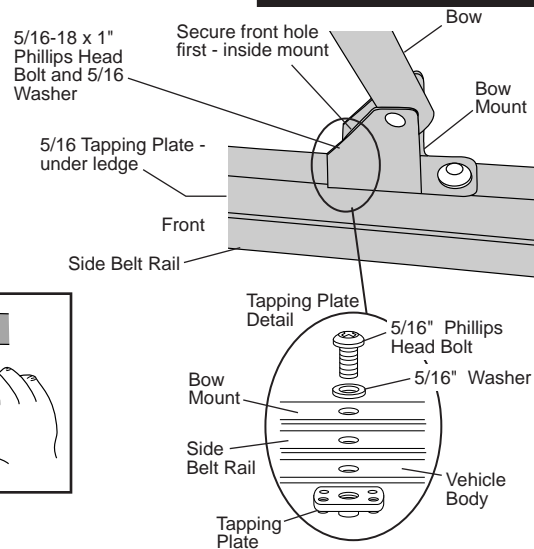
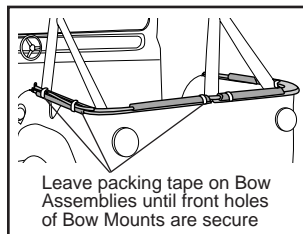

Supertop® – Installation Instructions

10 Install Top on Vehicle

Locate the top and orient it on the vehicle. Drape the top over the bows and insert the plastic strip sewn along the front of the top into windshield retainer attached on the front of the windshield frame. Center the front of the deck on the vehicle so that it is an equal distance from the top of the windshield flange on both sides.

NOTE For best possible installation, check to make sure that the soft top is perfectly centered on the vehicle.

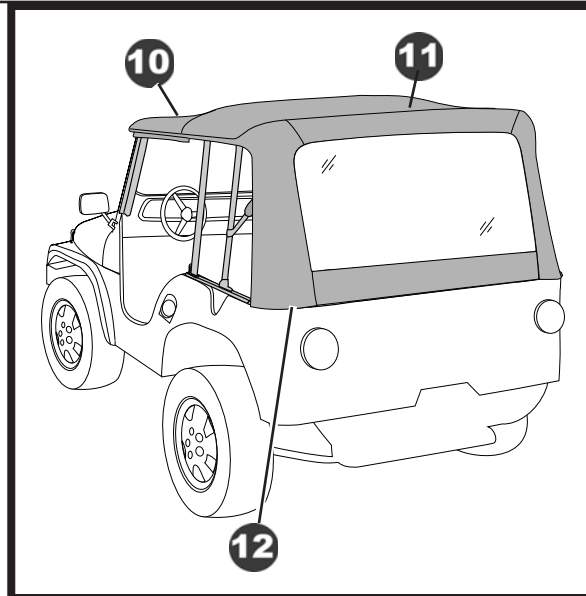
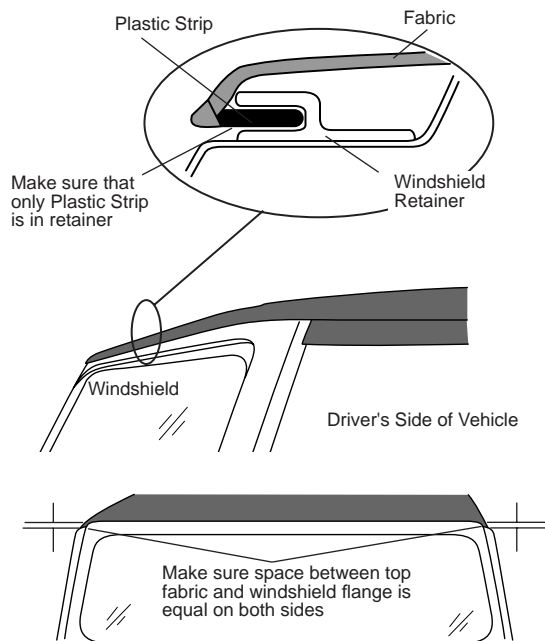

11 Snap Top to Rear Bow

Snap the flaps to the six studs on the rear bow.

NOTE If the snaps don't appear to line up, push the rear bow forward to relieve the pressure on the bow. This will allow the snaps to line up more easily.

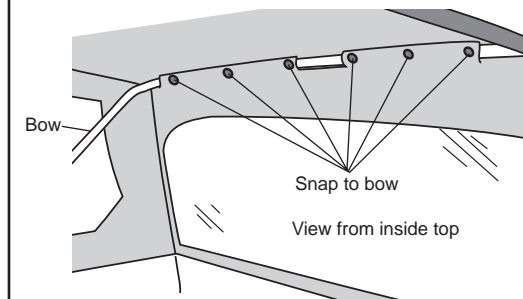

12 Secure Rear Corners

Insert the black plastic strips at rear corners of top into Corner Belt Rails. Slide the fabric around toward the rear of the vehicle and center it on the bolt securing the corner retainer.

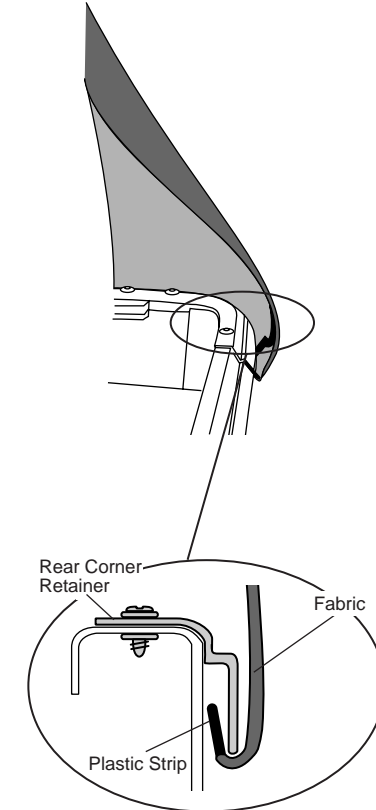

Supertop® – Installation Instructions

13 Raise the Rear Bow

Slide the Rear Bow up on the Front Bow and insert the small bent tab into one of the four holes in the Front Bow.

NOTE If the top is extremely tight, slip the tab into the bottom hole. The top will loosen up after a few hours in the sun. Then the tab may be inserted into a higher hole position.

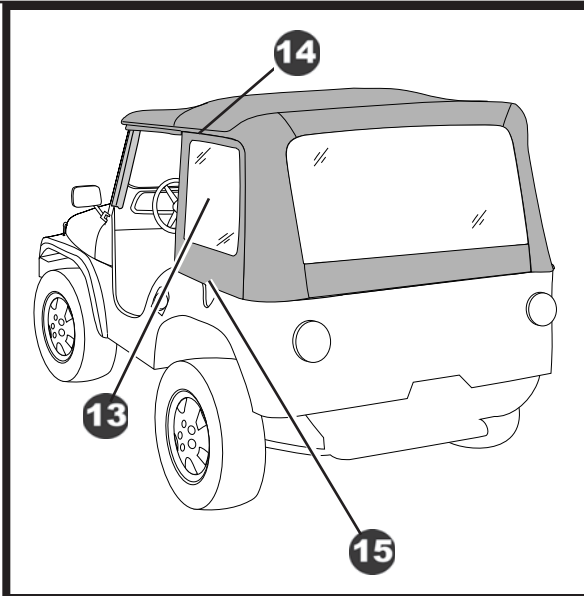
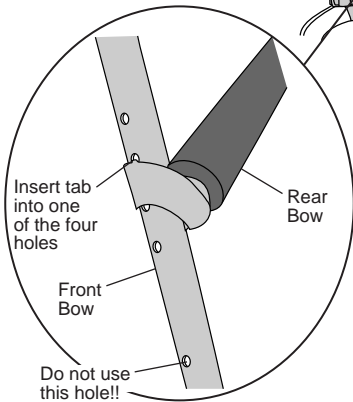
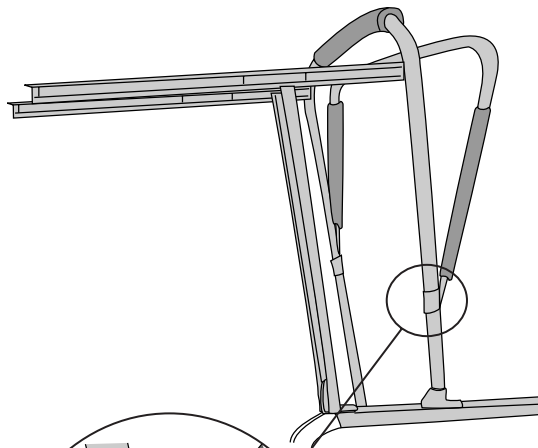

14 Install Side Curtain

Start top and rear zippers on side curtain 6 inches.

NOTE If necessary, release the Bow Coupler and slide the top around the Corner Belt Rail towards the window to make it easier to start the zippers on the Side Curtains.

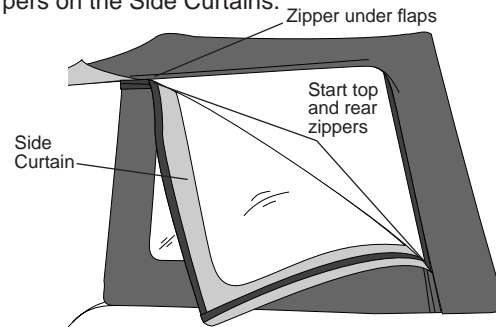

15 Secure Bottom of Side Curtain

Slip the plastic strip on the bottom of the side curtain into the side retainer. Close the top zipper on the side curtain.

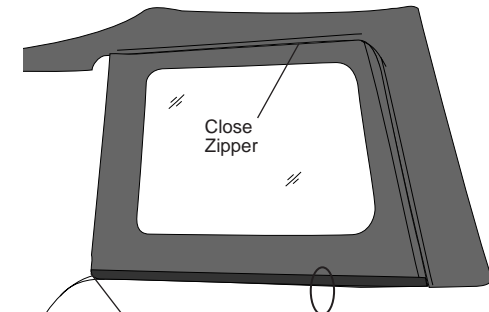

Start at one end of the strip and work along it to the other end.

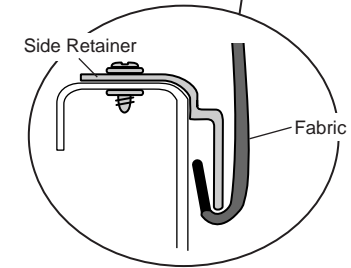

Supertop® – Installation Instructions

16 Secure Front of Side Curtain

Insert the plastic strip sewn along the front of the side curtain into the Vertical Retainer. Close the rear zipper on the side curtain.

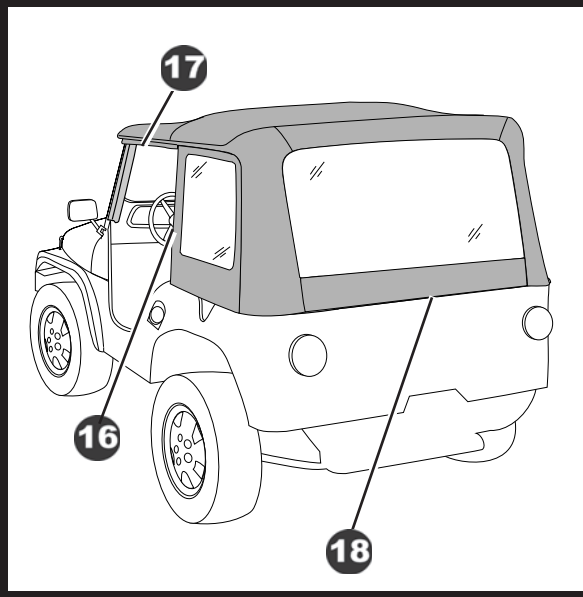
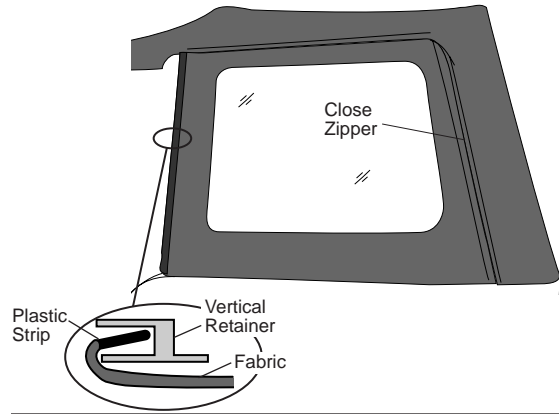

17 Secure Door Flaps

Wrap the flap, sewn to the top above each door, around the Horizontal Rod and fasten the hook and loop strips to each other.

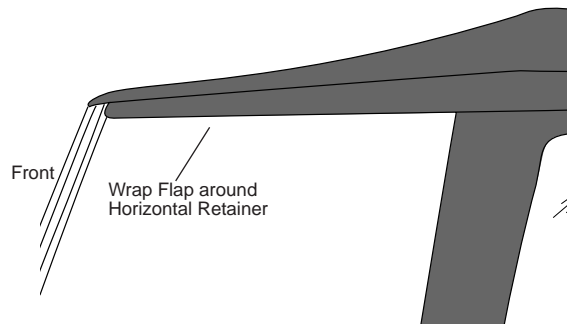

On tailgate vehicles

Locate the flap with five snaps sewn to the bottom of the Rear Curtain. Lay the plastic strip in the Rear Curtain inside the vehicle. Snap the snap flap to the existing studs on the vehicle. If the snaps are damaged or missing, or if they need to be relocated, mark the snap location and mark center punch and drill a 3/32" hole at each location. Install each snap stud with a #6 x 3/8" Sheet Metal Screw.

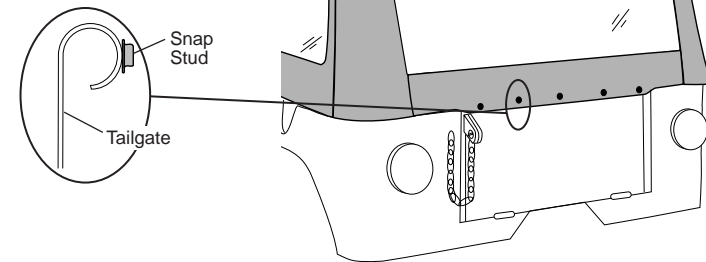

18 Secure Top to Tailgate

On non-tailgate vehicles

Slip the plastic strip sewn to the bottom of the Rear Curtain into the Tailgate Retainer. Center the Rear Curtain. Close the side zippers.

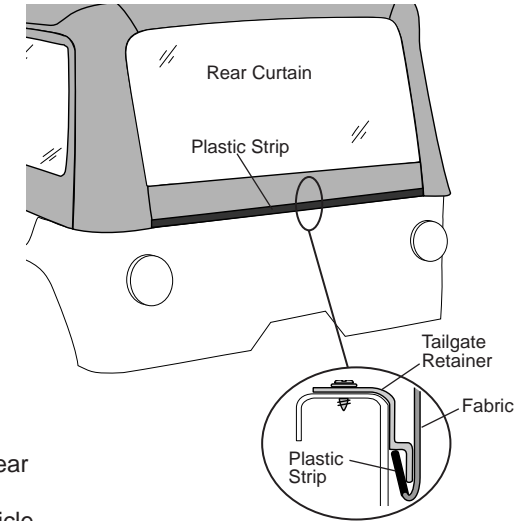

Supertop® – Installation Instructions



WARNING

Door handles are only designed to aid in door closure. Door and handle WILL NOT support a person's weight.

19 Install Handle on Doors

Locate the pre-cut "X" in the lower door panel where the Paddle Handle will fit into the mounting plate on the door frame. Fold the pre-cut fabric back and insert the Paddle Handle into the mounting plate so that the latch mechanism is inside of the vehicle and the latch bolt is toward the rear of the door. Start with the Paddle Handle Assembly at an angle to the door and rotate it into position as shown in the video. Align the four holes in the Paddle Handle Assembly with the four holes in the mounting plate. Match the holes in the Paddle Handle and the mounting plate with the four pre-cut holes in the fabric. Insert four #10-24 Truss Head Machine Screws from the outside and secure them with #10-24 Locknuts. Do not tighten the screws until all four are in place. Use a Utility Knife or a Razor Blade to trim the excess fabric around the Paddle Handle. Repeat for both lower doors.

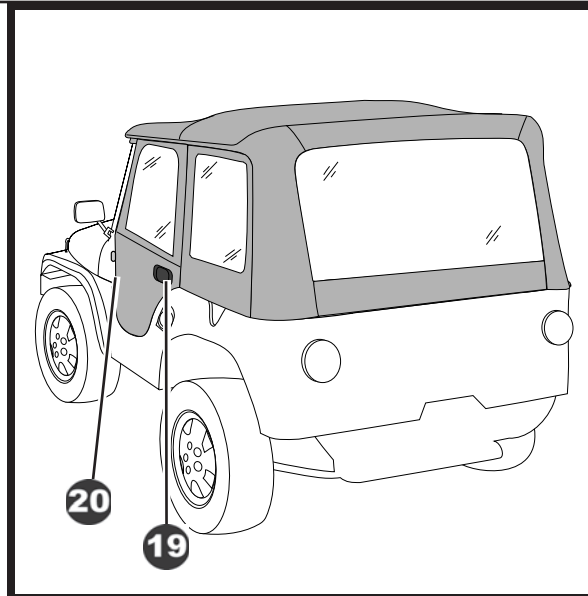

20 Install Doors on Vehicle

Remove the plastic caps from the Lower Door Hinge Pins. Hold the door straight out from the vehicle with the hinge pins over the body hinges. Lower the pins into the hinges. Make sure that the pins are fully inserted into the body hinges. Close the door and check all sides to make sure that it fits properly against the body.

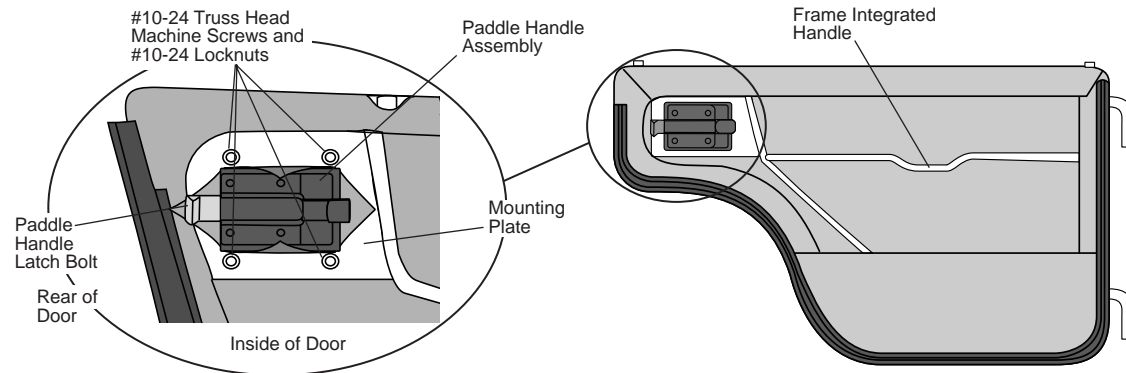
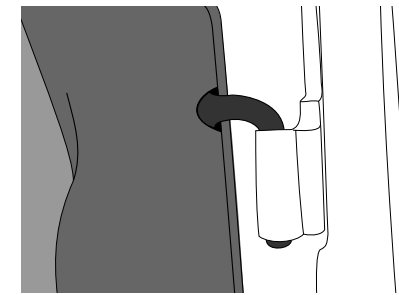

Supertop® – Installation Instructions

21 Adjust Doors

Locate the Lower Hinge Pin Adjustment Plate on the Lower Door frame. If the Lower Door needs to be adjusted for a better fit against the body, use a 7/16" Wrench to loosen the two nuts in the adjustment plate. Slide the Hinge Pin backward or forward as necessary for the best fit. Tighten the nuts.

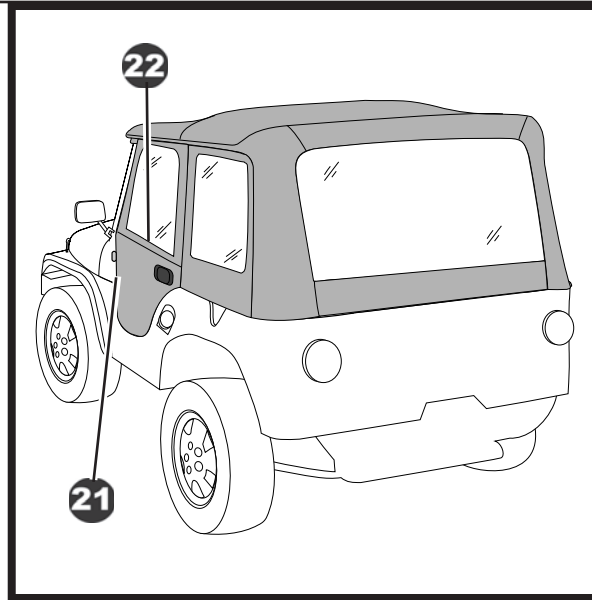
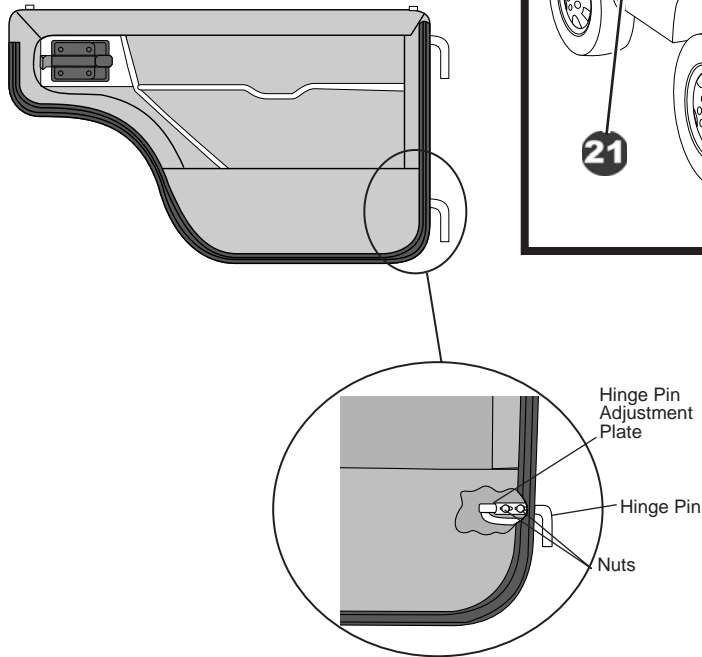

22 Install Upper Doors

Remove the plastic caps from the Upper Door Pins and install the upper door into the lower door. Starting with the front pin, slip the pins into the sockets in the lower door. Make sure that the pins are well seated in the sockets. Close the door to check that it fits properly against the body. The Door Striker may be adjusted in or out until you are satisfied with the way the door shuts and opens. If necessary for proper door fit, bend the door slightly inward (see video). Once the doors close and seal properly, cut off the excess rubber seal at the front of the door.

NOTE Lubricating the upper door pins with a light weight oil will make it easier to install and remove the upper door.

NOTE Once the door has been installed on the vehicle, check the alignment between the latch and the Door Striker installed in Step 6. The Door Striker may be adjusted in or out until you are satisfied with the way the door shuts and opens. Repeat on both sides of the vehicle.

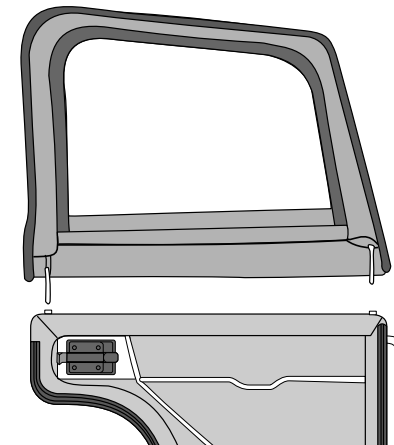

Supertop® – Installation Instructions



WARNING

When operating the vehicle without the Side Curtains, the Rear Curtain should be rolled up for proper ventilation.

23 Adjusting the Top

Side Curtains

To remove the Side Curtains. Unzip the rear and top zippers. Release the plastic strips from the retainers.

Rear Curtain

To roll up the Rear Curtain, start at the bottom and roll it to the inside. Avoid wrinkles in the fabric and window. Secure it in place with the curtain straps inside of the top.

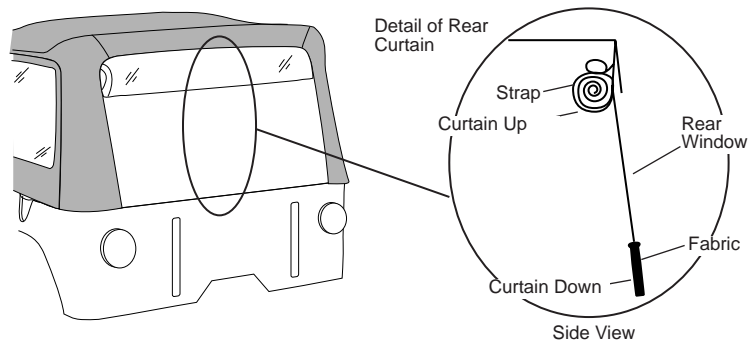

Upper Door

To roll the Door Glass, start at the top and roll to the inside, avoiding wrinkles. Secure it with the elastic strap, close snap to the outside of the door.

24 Folding the Top Down

Open the zippers at the rear of the Side Curtains. Pull the plastic strip on the bottom of the Side Curtains out of the Belt Rails. Leave the rear corners of the top attached to the Corner Belt Rails. Unfasten the plastic strip at the front of the Side Curtains, releasing the Side Curtains from the Vertical Retainer. Fold the Side Curtains up onto the top and release the hook and loop fasteners on the flaps, above the doors. Unsnap the top from the rear bow.

Release the locking tabs on the Bow Releases from the holes in the bow and slide the rear bow down to the Bow Mounts. Release the Horizontal Rod from the Windshield Bracket. Remove the Vertical Rod from the Vertical Retainer Mount and lay the bow assembly down on the rear of the vehicle.

Unfasten the top from the windshield and lay it down on the body. Make sure that the rear corners of the top are tucked under the rear bow. Fold the top in half from front to back and continue folding until the top is about 1 foot wide at the rear of the vehicle. Secure the top by clipping the Bow Tie Downs into the Side Belt Rails.

25 Removal of Soft Top for Open Air Driving

When operating the vehicle with the fabric top removed, it is very important that the supporting hardware system be disconnected from the windshield bracket and folded flat to the rear of the vehicle. Wrap the elastic straps around the bows and insert the plastic strip into the side belt rail. Never operate the vehicle with the fabric removed and the hardware in the fully erected position.



Care and Maintenance of your Bestop Product

Your Bestop product is made of the finest materials available. To keep it looking new and for the maximum possible wear, it will need periodic cleaning and maintenance.

Fabric: The fabric should be washed often using soap, warm water and a soft bristle brush. Rinse with clear water to remove all traces of soap. Bestop recommends using Bestop Cleaner (part no. 11201-00) and Bestop Protectant (part no. 11202-00) for Vinyl fabric and Bestop Twill Protectant (part no. 11207-00) for Twill fabric. Bestop Cleaner and Bestop protectant are specially formulated to provide a total cleaning and protection system. Bestop Cleaner safely removes the toughest stains, will not harm vehicle finishes, is biodegradable and environmentally friendly. Bestop Protectant protects against UV-fading, cracking and hardening, and repels dust, grease, dirt and mildew.

Windows: Keep windows clean to avoid scratching. DO NOT use a brush on the windows! Wash with a water-soaked cloth or sponge and a mild dishwashing detergent. Bestop recommends Bestop Vinyl Window Cleaner (part no. 11203-00), which safely cleans and protects vinyl windows and helps prevent UV damage. NEVER WIPE THE WINDOWS WHEN THEY ARE DRY. Be careful when cleaning snow or frost from the vinyl windows since they are easily scratched and may crack at low temperatures. DO NOT roll the sides or rear window in cold weather. The windows become stiff and will crack. Cracks caused by misuse in cold temperatures are not covered under warranty.

Water: Seeping through at the seams may be stopped by applying 3-M Scotchgard® on the inside of the seams.

Snaps: Keep snaps cleaned and lubricated with silicone to help prevent snaps from sticking to the studs. If a snap does become stuck to a stud, use a screwdriver and GENTLY pry apart to prevent permanent damage to the snap or the top fabric.

Zippers: Keeping zippers cleaned and lubricated with Bestop's Zipper Cleaner (part no. 11206-00) will help prevent damage and keep the zippers in smooth working condition. If a zipper opens behind the slider, the slider may have been spread apart. This problem can usually be repaired by using an ordinary pair of pliers to bring the sides back into parallel. Return slider to the end of the zipper in the normal Open position. Squeeze lightly at first and test the zipper. If the zipper continues to remain open squeeze more firmly with the pliers and try the zipper again. Repeat this procedure until the zipper operates correctly.

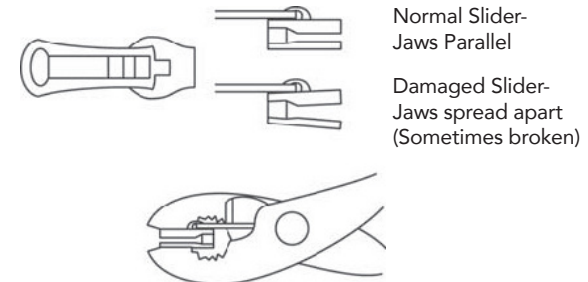

For Bestop Warranty Information, Please go to;
<https://www.bestop.com/help/warranty-information/>

