









Installation Instructions Front 2 Piece Door with Rotary Latch

Vehicle Application

- Jeep Wrangler JK and Wrangler JK Unlimited (2 Door and 4 Door Models)
2007 to 2018
Part Number: 51798

www.Bestop.com - We're here to help! Visit our web site and click on "[Ask a Question](#)". Click here for more [Jeep Accessories by Bestop](#).

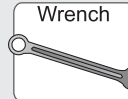
INSTALLATION TIME	SKILL LEVEL
 1/2 Hour	 2 - Moderately Easy

TOOLS			
 Safety Glasses	 Phillips Screwdriver	 Wrench 7/16" and 3/8"	 Utility Knife



Use of this product will eliminate the factory side mirrors and requires the removal of the entry light bulbs.

Installation Tips

Before you begin installing this assembly, read all instructions thoroughly.

For a smooth fit:

For ease in installation, the product should be installed at temperatures above 72° F. Below this temperature, the fabric may contract an inch or more, making it difficult to fit to the vehicle. It is normal for fabric to contract and wrinkle when stored in the shipping carton. Within a few days after the installation, the fabric will relax and the wrinkles will disappear.

 **CAUTION** Safety glasses should be worn at all times while installing this product.

 **WARNING** This product is designed primarily to enhance the appearance of the vehicle and to shield the occupants from ordinary weather conditions. Do not rely in any way on the components of this product to contain occupants within the vehicle, or to protect against injury or death in the event of an accident. This product will not protect the occupants from falling objects. Never operate the vehicle in excess of manufacturer's specifications.

WEAR SEAT BELTS AT ALL TIMES

Read and follow, precisely, all installation instructions provided when installing product. Failure to do so may result in a poor fit and could place occupants of the vehicle in a potentially dangerous situation.

2 Piece Soft Door – Installation Instructions

Parts List

Upper Door, Rt. Qty - 1
 Upper Door, Lt. Qty - 1
 Lower Door, Rt. Qty - 1
 Lower Door, Lt. Qty - 1
 Spacer Kit Qty - 1

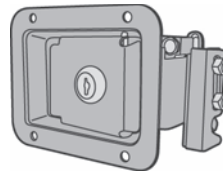

Latches, Locking Rotary Paddle Handle with Key - Qty - 1, Part Number 459.24,
 Qty - 1, Part Number 459.25

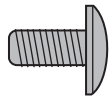

#10-24 Truss Head Machine Screw - Black, Qty - 8, Part Number 195.92



#10-24 Locknut, Qty - 8, Part Number 195.93

Allen Wrench, Qty - 1, Part Number 276.68

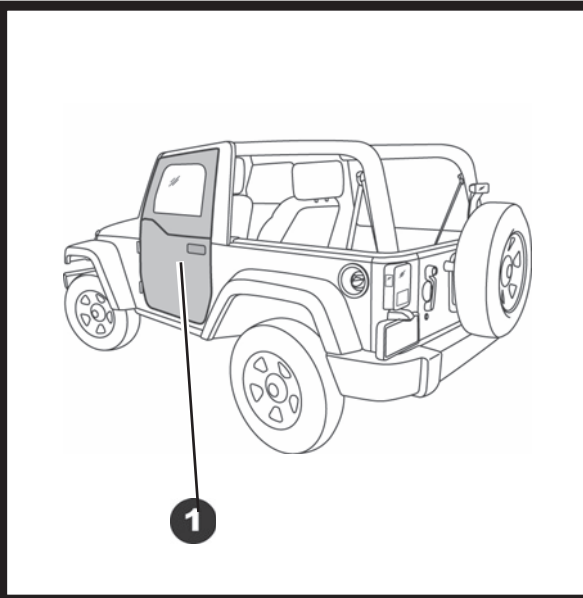

WARNING

It is important that the Paddle Handle must align correctly with the automobile manufacturer's original equipment steel latch pin located on the vehicle. Failure to properly install the paddle handle may result in the door accidentally opening. **IMPROPER CLOSURE COULD RESULT IN SERIOUS INJURY OR DEATH TO THE OCCUPANTS. WEAR SEAT BELTS AT ALL TIMES. DRIVE CAREFULLY.**



CAUTION

DO NOT attempt to adjust the Original Equipment Latch Pin. Doing so could result in damage to the pin.



1 Install Paddle Handle

Locate the pre-cut "X" in the lower door panel where the Paddle Handle will fit into the mounting plate on the door frame. Fold the pre-cut fabric back and insert the Paddle Handle into the mounting plate so that the latch mechanism is inside of the vehicle and the latch bolt is toward the rear of the door. Align the four holes in the Paddle Handle Assembly with the four holes in the mounting plate. Use a utility knife to punch four holes in the fabric to match the holes in the Paddle Handle and the mounting plate. Insert four #10-24 Truss Head Machine Screws from the outside and secure them with #10-24 Locknuts. Do not tighten the screws until adjustment in Step #2.

Important: You should check alignment of the Paddle Handle to the steel latch pin before tightening the screws. If out of alignment, align and retighten the screws securely.

Trim the excess fabric around the Paddle Handle. Repeat for both lower doors.



WARNING

The doors in this product are designed only for protection against the elements. Do not rely on the doors to contain occupants within the vehicle or to protect against injury during an accident. Door handles are only designed to aid in door closure. Door and handle will not support a person's weight.



If your vehicle does not have the latch pin assembly illustrated here, you have an incorrect part for your vehicle. Please call the 1-800 number before attempting installation.

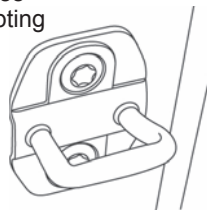

Special Note: The Rotary Latch Paddle Handle will only latch on the automobile manufacturer's original equipment steel latch pin located on the vehicle. Do Not adjust or remove this part.

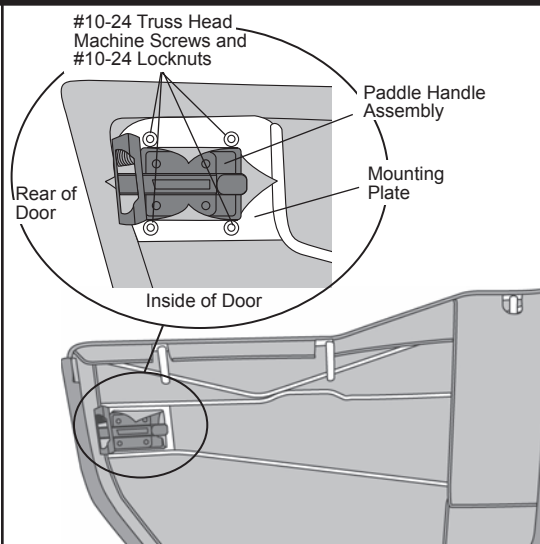

2 Piece Soft Door – Installation Instructions

2 Install Door

Hold the door open and perpendicular to the vehicle with the hinge pins over the body hinges. Lower the pins into the hinges. Make sure that the pins are fully inserted into the body hinges. Close the door and check all sides to make sure that the door fits properly against the body. The latch can be adjusted for the best contact to the latch pin by loosening the four mounting screws and sliding the latch forward or rearward. Tighten all screws after the adjustment.

Some Installations require bending of this steel pin

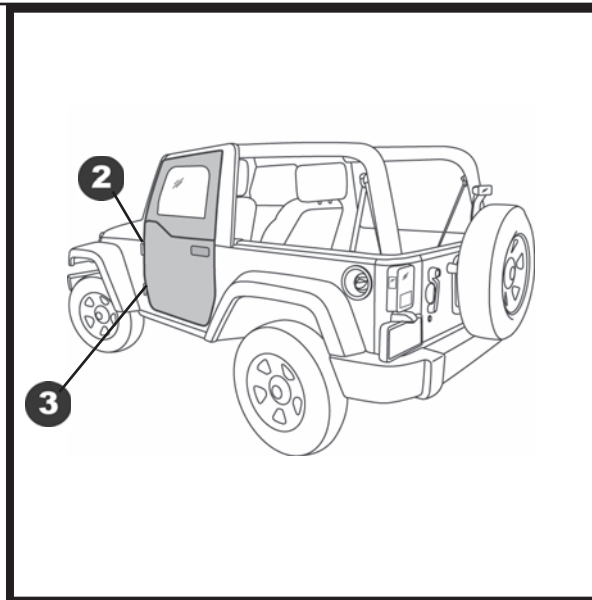
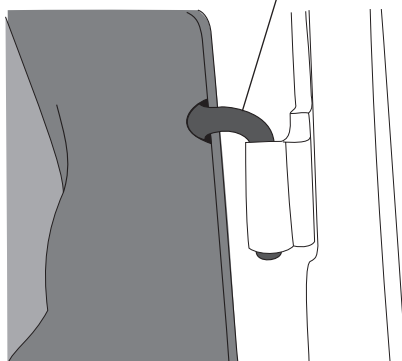

3 Adjust Door

Locate the Lower Hinge Pin Adjustment Plate on the Door frame. If the Door needs to be adjusted for a better fit against the body, use a 7/16" Wrench to loosen the two nuts in the adjustment plate. Slide the Hinge Pin backward or forward as necessary for the best fit. Tighten the nuts.

NOTE If the lower door pivot does not provide enough adjustability for correct latch adjustment (the door does not latch properly), follow the instructions in the enclosed spacer kit.

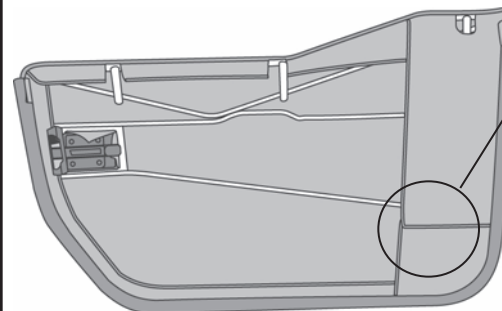
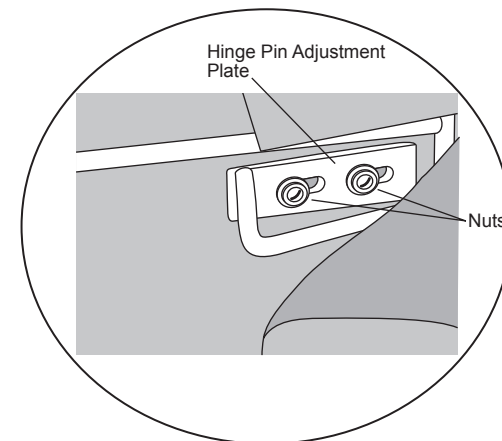

2 Piece Soft Door – Installation Instructions

4 Install Upper Door

Install the upper door into the lower door. Starting with the front pin, slip the pins into the sockets in the lower door. Make sure that the pins are well seated in the sockets. Close the door to check that it fits properly against the body. If necessary, use a 1/8" Allen Wrench to loosen the Collars on the front and rear upper door pins. The Collars will slide up or down as needed to provide the best fit of the Upper Door against the windshield. Attach the loop strip on the bottom of the upper door to the hook strip on the top of the lower door. If necessary bend the door slightly for proper door fit.

NOTE Lubricate the upper door pins with a light weight oil to make it easier to install and remove the upper door.

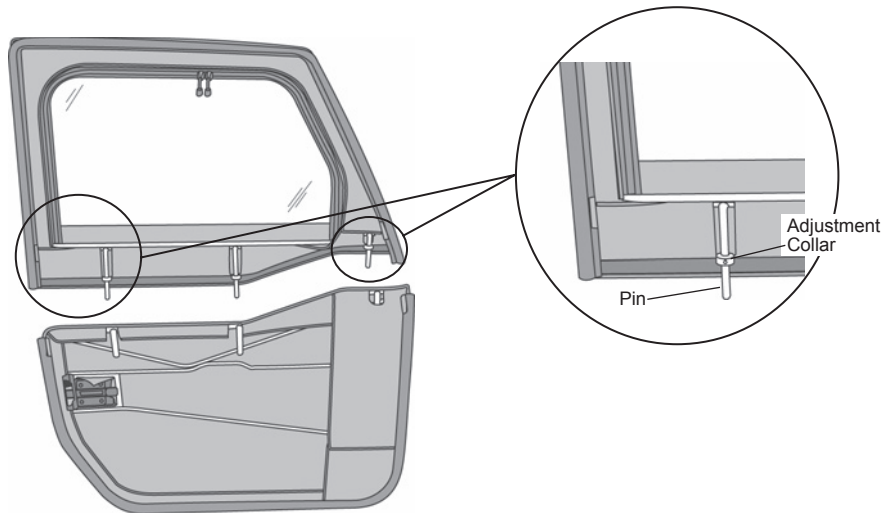
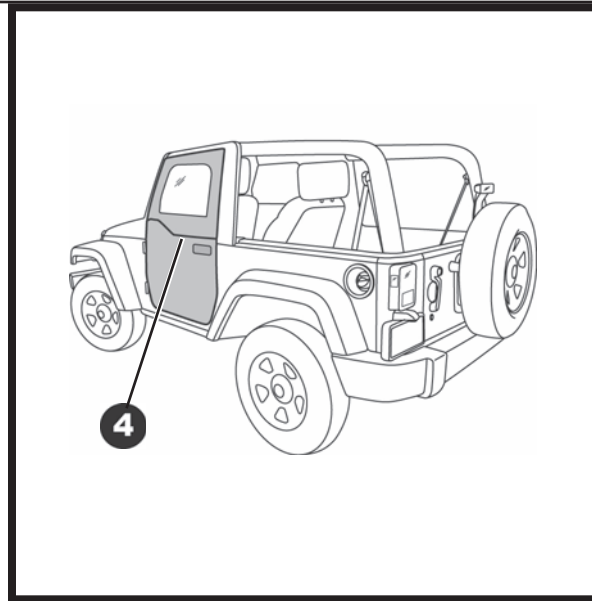



Care and Maintenance of your Bestop Product

Your Bestop product is made of the finest materials available. To keep it looking new and for the maximum possible wear, it will need periodic cleaning and maintenance.

Fabric: The fabric should be washed often using soap, warm water and a soft bristle brush. Rinse with clear water to remove all traces of soap. Bestop recommends using Bestop Cleaner (part no. 11201-00) and Bestop Protectant (part no. 11202-00) for Vinyl fabric and Bestop Twill Protectant (part no. 11207-00) for Twill fabric. Bestop Cleaner and Bestop protectant are specially formulated to provide a total cleaning and protection system. Bestop Cleaner safely removes the toughest stains, will not harm vehicle finishes, is biodegradable and environmentally friendly. Bestop Protectant protects against UV-fading, cracking and hardening, and repels dust, grease, dirt and mildew.

Windows: Keep windows clean to avoid scratching. DO NOT use a brush on the windows! Wash with a water-soaked cloth or sponge and a mild dishwashing detergent. Bestop recommends Bestop Vinyl Window Cleaner (part no. 11203-00), which safely cleans and protects vinyl windows and helps prevent UV damage. NEVER WIPE THE WINDOWS WHEN THEY ARE DRY. Be careful when cleaning snow or frost from the vinyl windows since they are easily scratched and may crack at low temperatures. DO NOT roll the sides or rear window in cold weather. The windows become stiff and will crack. Cracks caused by misuse in cold temperatures are not covered under warranty.

Water: Seeping through at the seams may be stopped by applying 3-M Scotchgard® on the inside of the seams.

Snaps: Keep snaps cleaned and lubricated with silicone to help prevent snaps from sticking to the studs. If a snap does become stuck to a stud, use a screwdriver and GENTLY pry apart to prevent permanent damage to the snap or the top fabric.

Zippers: Keeping zippers cleaned and lubricated with Bestop's Zipper Cleaner (part no. 11206-00) will help prevent damage and keep the zippers in smooth working condition. If a zipper opens behind the slider, the slider may have been spread apart. This problem can usually be repaired by using an ordinary pair of pliers to bring the sides back into parallel. Return slider to the end of the zipper in the normal Open position. Squeeze lightly at first and test the zipper. If the zipper continues to remain open squeeze more firmly with the pliers and try the zipper again. Repeat this procedure until the zipper operates correctly.

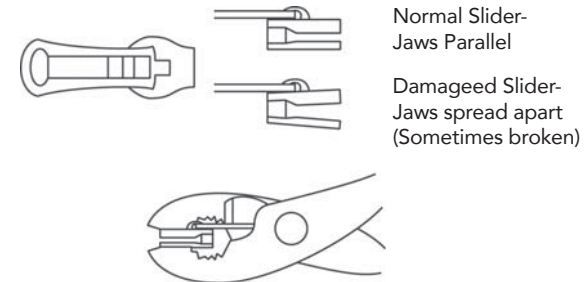

For Bestop Warranty Information, Please go to;
<https://www.bestop.com/help/warranty-information/>

