



Installation Instructions JK 4 Door Trektop Halftop

Vehicle Application:
Jeep® Wrangler JK Unlimited 2007-2018
Part Number 53901

Installation Tips

Before you begin installing your new Trektop NX, please read all the instructions thoroughly.

For easier installation, the top should be installed at a temperature above 72° F. Below this temperature, the fabric may contract making it difficult to fit the vehicle.



! WARNING Do not rely in any way on the components of this product to protect against injury or death in the event of an accident. Never operate the vehicle in excess of manufacturer’s specifications.

Read and follow, precisely, all installation instructions provided when installing this product. Failure to do so may result in a poor fit and could place occupants of the vehicle in a potentially dangerous situation.

! CAUTION Safety glasses should be worn at all times when installing this product.

WEAR SEAT BELTS AT ALL TIMES

Tools



#2 Phillips
Screwdriver



Vise-Grips



Ratchet



Sockets: 3/8"
8mm, 13mm



Safety
Glasses



Adjustable
Wrench

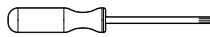

T40 Torx
Driver

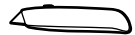

Utility Knife



3mm Allen
Wrench

Installation Time

2 00

2 Hours

Skill Level



3 - Moderately Difficult

Support

We're here to help!
Go to www.Bestop.com and
click on "Need Help?"



Installation Instructions JK 4 Door Trektop Halftop

Vehicle Application:
Jeep® Wrangler JK Unlimited 2007-2018
Part Number 53901

Sugerencias de Instalación

Antes de empezar a instalar esta unidad, lea atentamente todas las instrucciones.

Para un buen ajuste:

Para facilitar la instalación, el producto debe instalarse a temperaturas superiores a 72 °F (22 °C).

Por debajo de esta temperatura, la tela puede encogerse una pulgada o más, lo que dificultaría su ajuste al vehículo.

Es normal que la tela se contraiga o arrugue cuando está guardada en la caja de empaque. A los pocos días después de la instalación, la tela se relajará y las arrugas desaparecerán.



ADVERTENCIA

Este producto se diseñó principalmente para mejorar la apariencia del vehículo y proteger a los ocupantes de las condiciones climáticas comunes. De ninguna manera piense que los componentes de este producto pueden servir como medio de contención para los ocupantes del vehículo o que pueden protegerlos contra lesiones o la muerte en caso de accidente. Este producto no protegerá a los ocupantes contra caídas de objetos. Nunca conduzca este vehículo fuera de las especificaciones del fabricante.

USE LOS CINTURONES DE SEGURIDAD EN TODO MOMENTO

Lea y siga con precisión todas las instrucciones de instalación que se proporcionan para instalar este producto. Si no lo hace, podría producirse un mal ajuste que colocaría a los ocupantes del vehículo en una situación potencialmente peligrosa.



PRECAUCIÓN

Debe usar gafas protectoras en todo momento durante la instalación de este producto.

Conseils pour l'installation

Lire toutes les instructions au complet avant de commencer l'installation de cet assemblage.

Pour un ajustement sans problème :

Afin de faciliter l'installation, ce produit doit être installé à des températures au-dessus de 72 °F (22 °C).

Sous cette température, le tissu peut rétrécir d'un pouce (2,5 cm) ou plus, ce qui rendra l'ajustement sur le véhicule difficile.

Il est normal que le tissu rétrécisse et plisse pendant qu'il est dans la boîte d'expédition. En quelques jours après l'installation, le tissu se détendra et les plis disparaîtront.



AVERTISSEMENT

Ce produit est conçu principalement pour améliorer l'apparence du véhicule et pour protéger les occupants des conditions météorologiques usuelles. Ne jamais se fier aux composants de ce produit pour se protéger de blessures ou de la mort en cas d'accident. Ce produit ne protégera pas les occupants des chutes d'objets. Ne jamais utiliser le véhicule au-delà des caractéristiques techniques indiquées par le fabricant.

PORTER UNE CEINTURE DE SÉCURITÉ EN TOUT TEMPS

Lire et suivre, très fidèlement, toutes les instructions d'installation fournies lors de l'installation de ce produit. Ne pas suivre cette consigne peut causer une installation inadéquate et mettre les occupants du véhicule dans une situation potentiellement dangereuse.



MISE EN GARDE

Des lunettes de sécurité doivent être portées en tout temps lors de l'installation de ce produit.



Installation Instructions JK 4 Door Trektop Halftop

Vehicle Application:
Jeep® Wrangler JK Unlimited 2007-2018
Part Number 53901

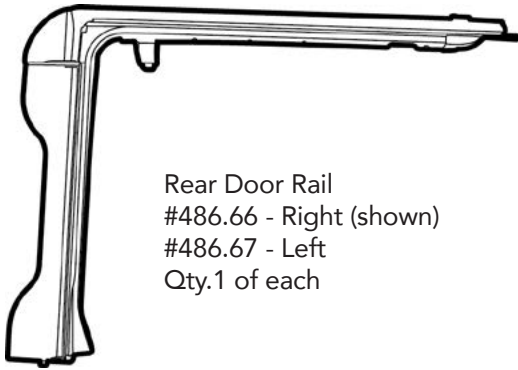

Rear Door Rail
#486.66 - Right (shown)
#486.67 - Left
Qty.1 of each



Front Door Rail
#479.87 - Left (shown)
#479.86 - Right
Qty. 1 of each

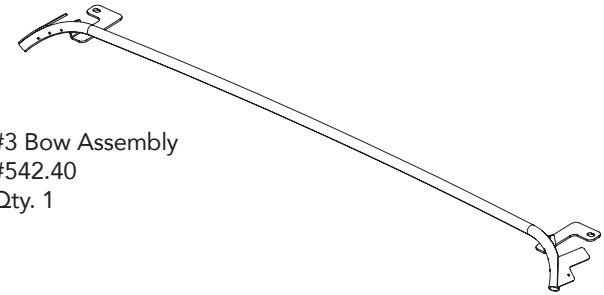

#3 Bow Assembly
#542.40
Qty. 1

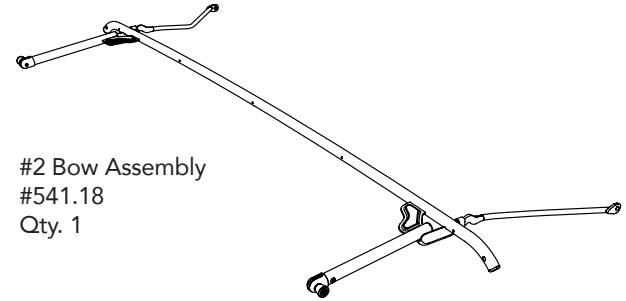

#2 Bow Assembly
#541.18
Qty. 1

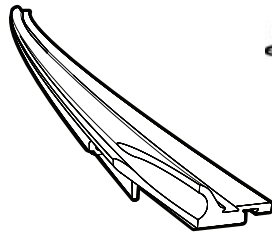

Tailgate Bar
#538.76
Qty. 1



Rear Top Arch
#483.27
Qty. 1

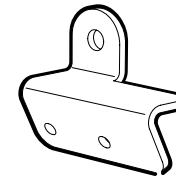

Sunrider Pivot Bracket
#544.18 - Right (shown)
#544.19 - Left
Qty. 1 per side

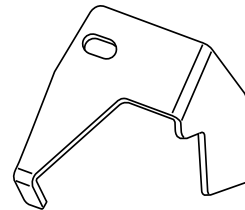

D Pillar Bracket
#616.30 - Right (shown)
#616.31 - Left
Qty. 1 per side

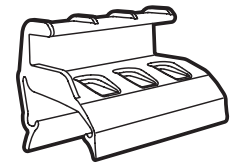

Tailgate Bar Mounts
#539.57 - Left (shown)
#539.56 - Right
Qty. 1 per side

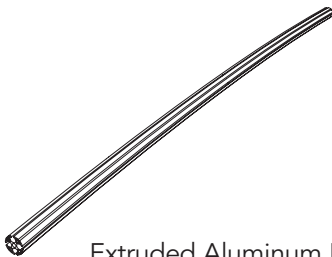

Extruded Aluminum Bow
Qty. 1
Part # 620.81



Bow D Pillar
Part #616.61
Qty. 2

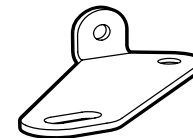

#2 Bow Pivot Bracket
#541.88 - Right (shown)
#541.87 - Left
Qty. 1 per side



Installation Instructions JK 4 Door Trektop Halftop

Vehicle Application:
Jeep® Wrangler JK Unlimited 2007-2018
Part Number 53901

Kit # 630.67

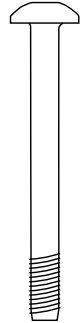

M8 x 80 Screw
#532.23
Qty.4
T-40



M8 x 38 Screw
#532.17
Qty.2
T-40



#10-24 x 3/8"
Machine Screw
Part #195.92
Qty. 4
#2 Phillips

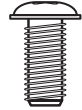

M5 x 35mm Screw
Part #514.62
Qty. 2
3mm Hex Socket



Plastic Bushing
Part #473.40
Qty. 4



Washer
Part #575.27
Qty. 2



Bestop Window Sticker
Part #338.32
Qty. 1



M5 Nylon Lock Nut
Part #526.76
Qty. 2

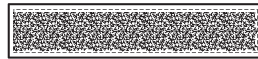

Adhesive Fabric
Loop Strips
Part #630.66
Qty. 2

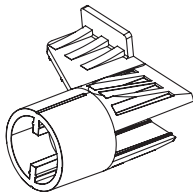

Plastic End Cap
Part # 592.66 Right (Shown)
Part # 593.71 Left
Qty. 1 per side

Kit # 630.68

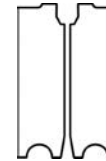

Foam Seals
#457.76 - Right
#457.77 - Left
Qty. 1 per side



Foam Seal
#605.46
Qty. 1



Foam Tape
Strips
#417.43
Qty. 2

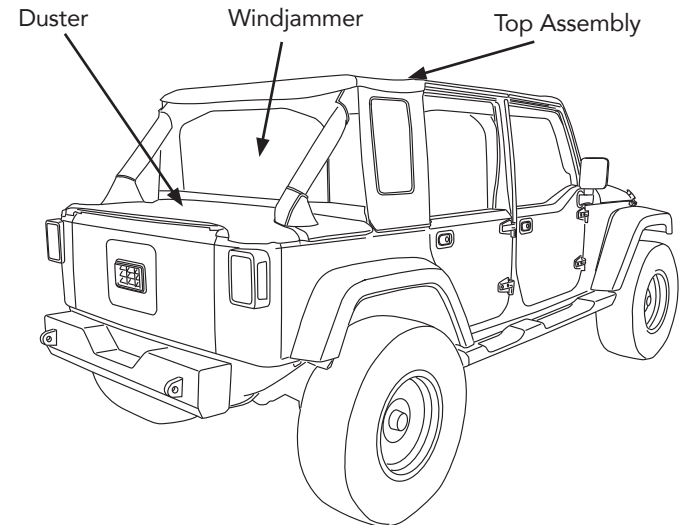

Tools

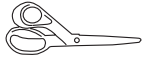

Scissors

Parts

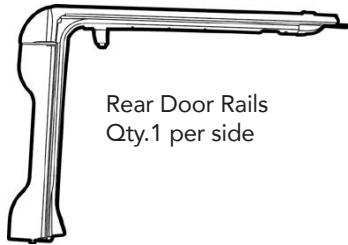

Rear Door Rails
Qty.1 per side

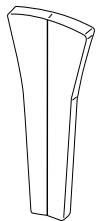

Foam Seal
Qty. 1

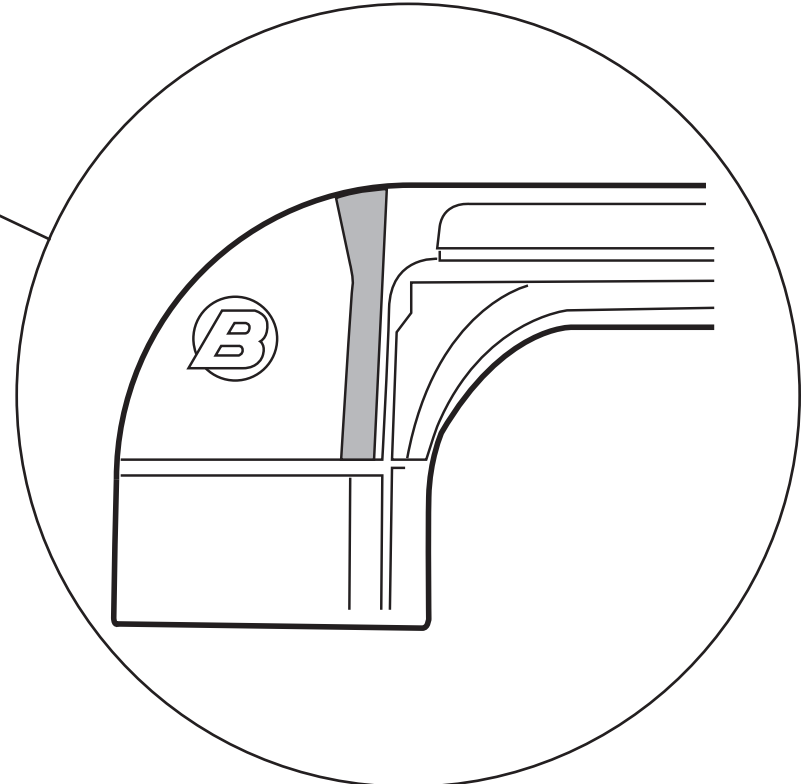
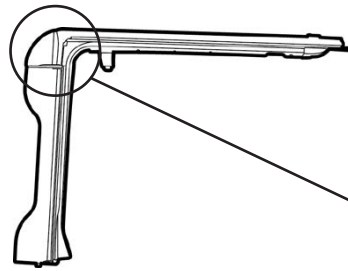

Cut along
this line.

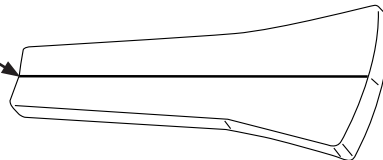

Cut the Foam Seal in half following the slit in the foam. Attach half of the Foam Seal into the valley of the Rear Door Rail.

Repeat for the left side.

Tools



T40 Torx
Driver

Parts

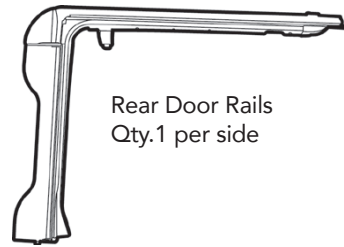

Rear Door Rails
Qty.1 per side

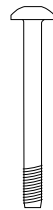

M8 x 80 Screw
Qty.2

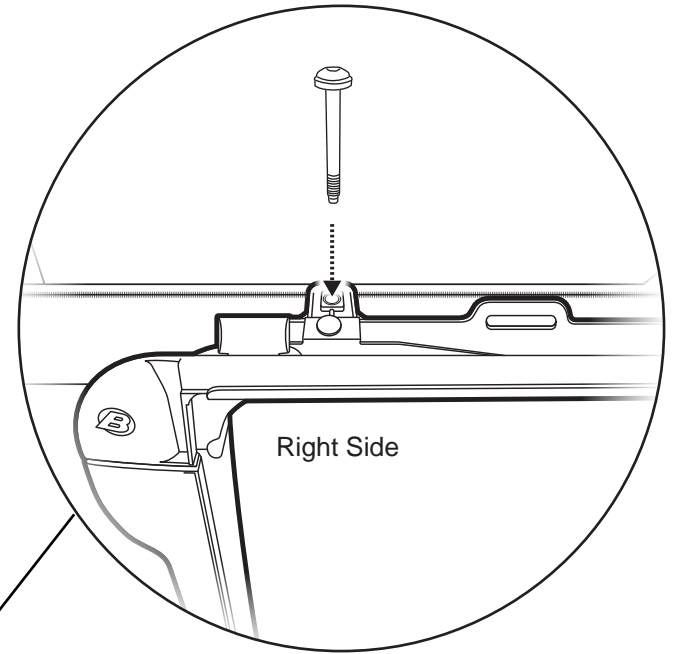
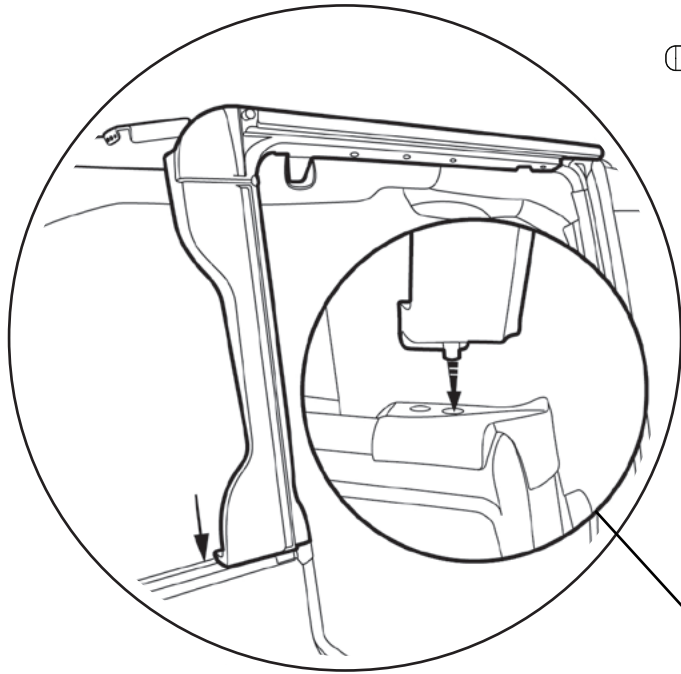

Open the Rear Door.

Insert the pin in the bottom of the right Rear Door Rail into the hole in the belt rail behind the rear door opening. Press the channel along the top of the Rear Door Rail around the horizontal sport bar.

Repeat on the left side of the vehicle.

Insert one (1) M8 x 80 Screw into the rear position on the right Rear Door Rail #486.67. Tighten to 55lb/in (4.5lb/ft).

Repeat on the left side of the vehicle.

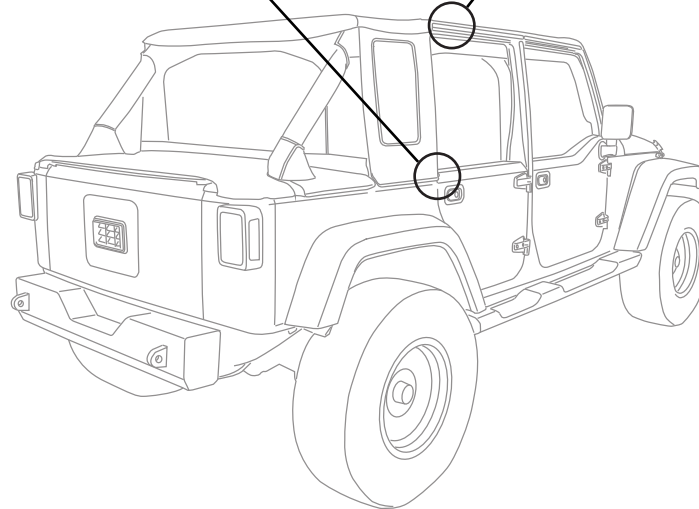

Tools

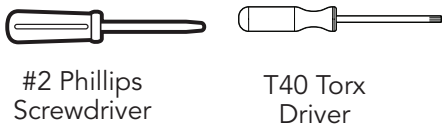

Parts

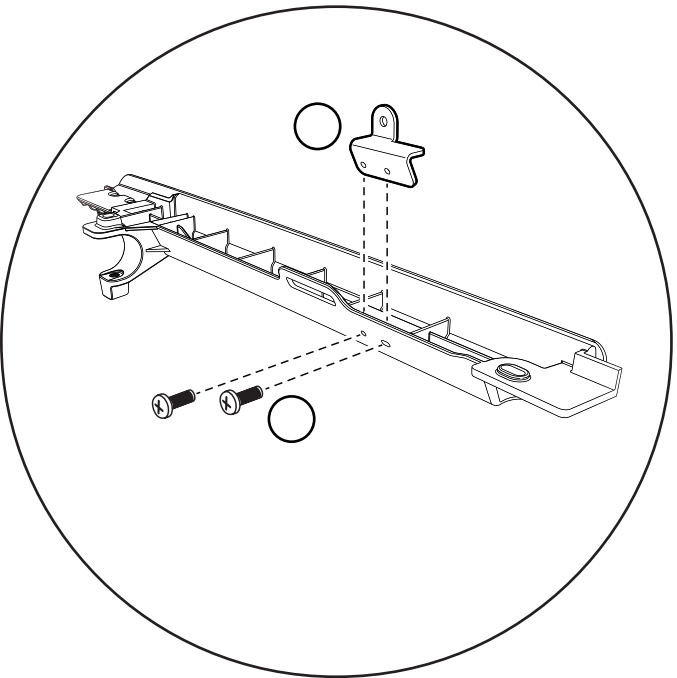
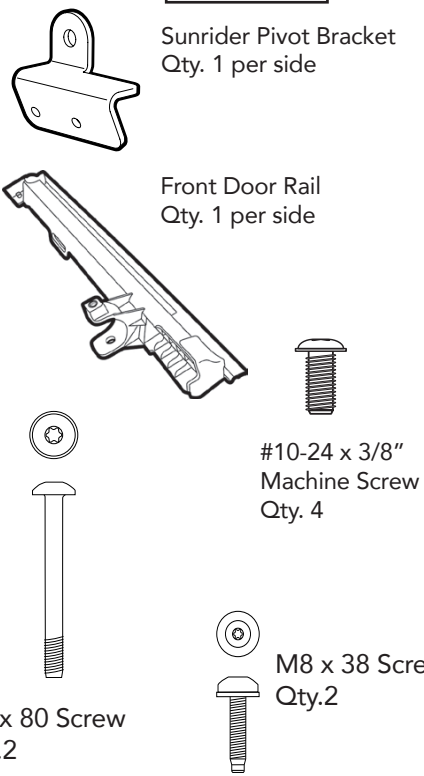

Attach the right Sunrider Pivot Bracket to the right Front Door Rail using two (2) #10-24 x 3/8" Screws.
Repeat on the left side of the vehicle, using the Left Sunrider Bracket.

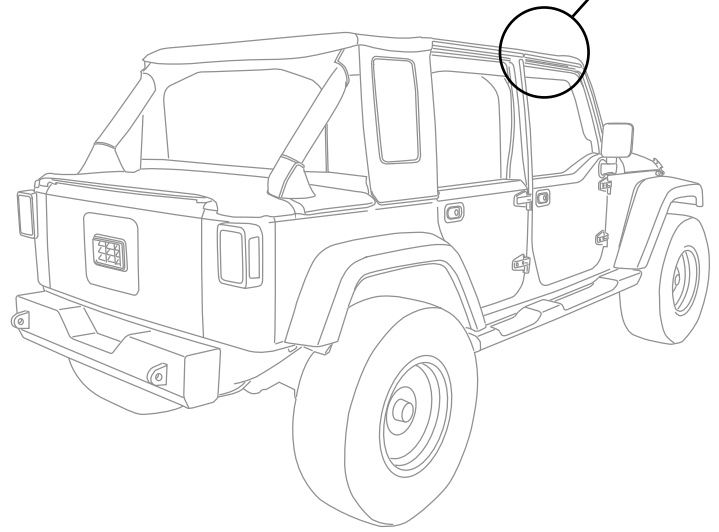
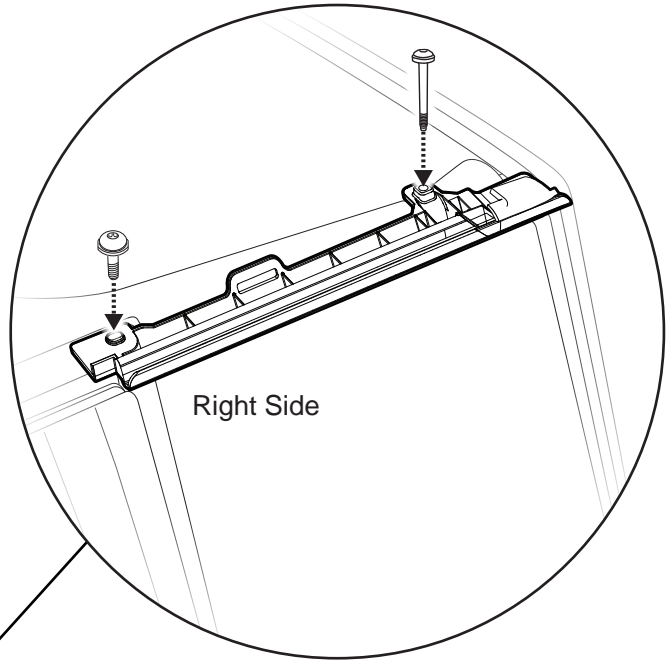

Open the front door.
Position the right Front Door Rail on the sport bar above the passenger side door and press it into place on the sport bar.
Secure the Front Door Rail in place with one (1) M8 x 80 Screw at the front, and one M8 x 38 Screw at the rear, where the Front Door Rail and Rear Door Rail overlap. Tighten to 55lb/in (4.5lb/ft).
Repeat on the left side of the vehicle.

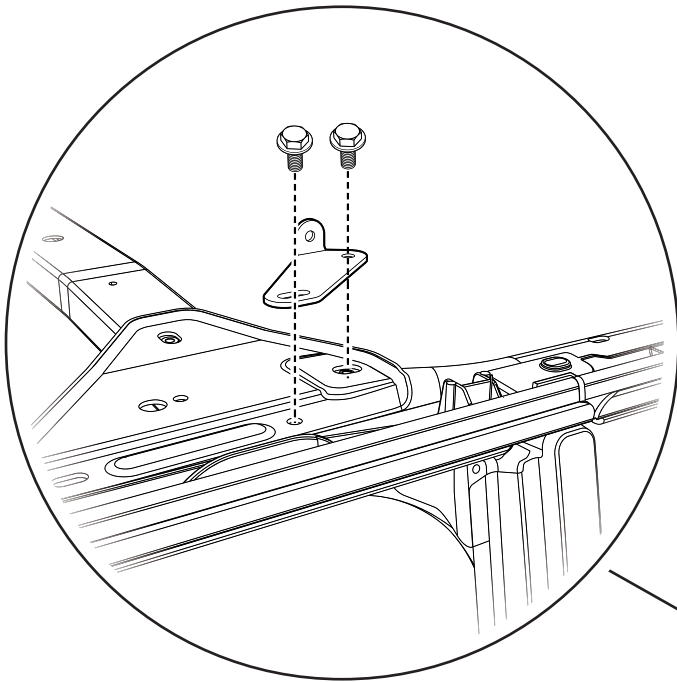

Tools

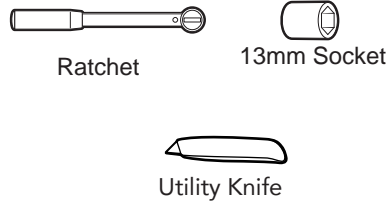

Parts

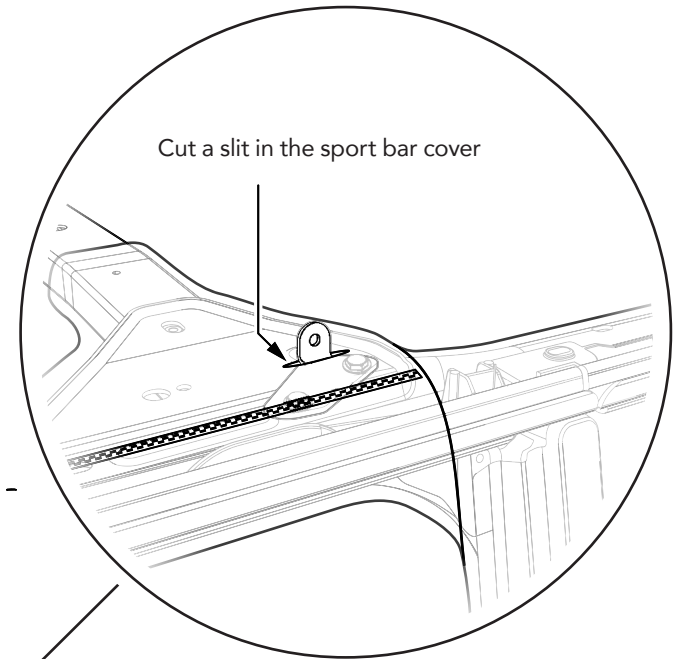
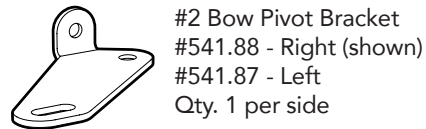

Unzip the sport bar cover over the middle cross bar between the front and rear doors, to expose the sport bar corner plate, and two factory-installed hex-head bolts.

Attach the Right #2 Bow Pivot Bracket to the right side sport bar plate using the two factory bolts.

Repeat on the left side of the Jeep.

Zip the sport bar cover closed.

Locate the vertical tab on the #2 Bow Pivot Bracket, and cut a slit in the cover to allow this tab to protrude through the cover.

Repeat on the left side of the Jeep.

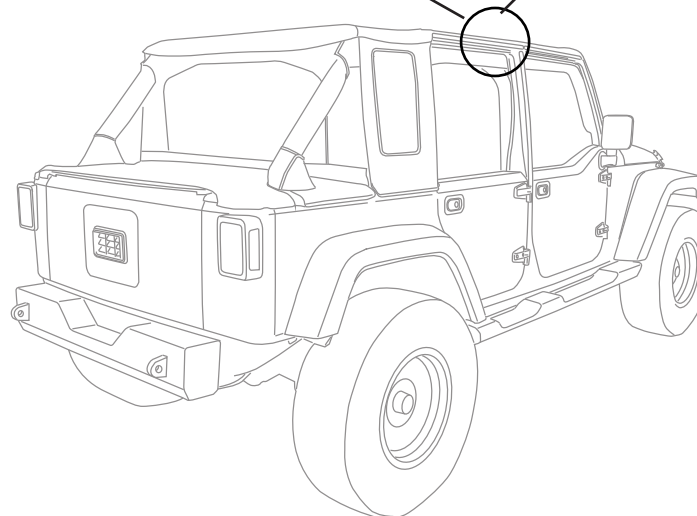

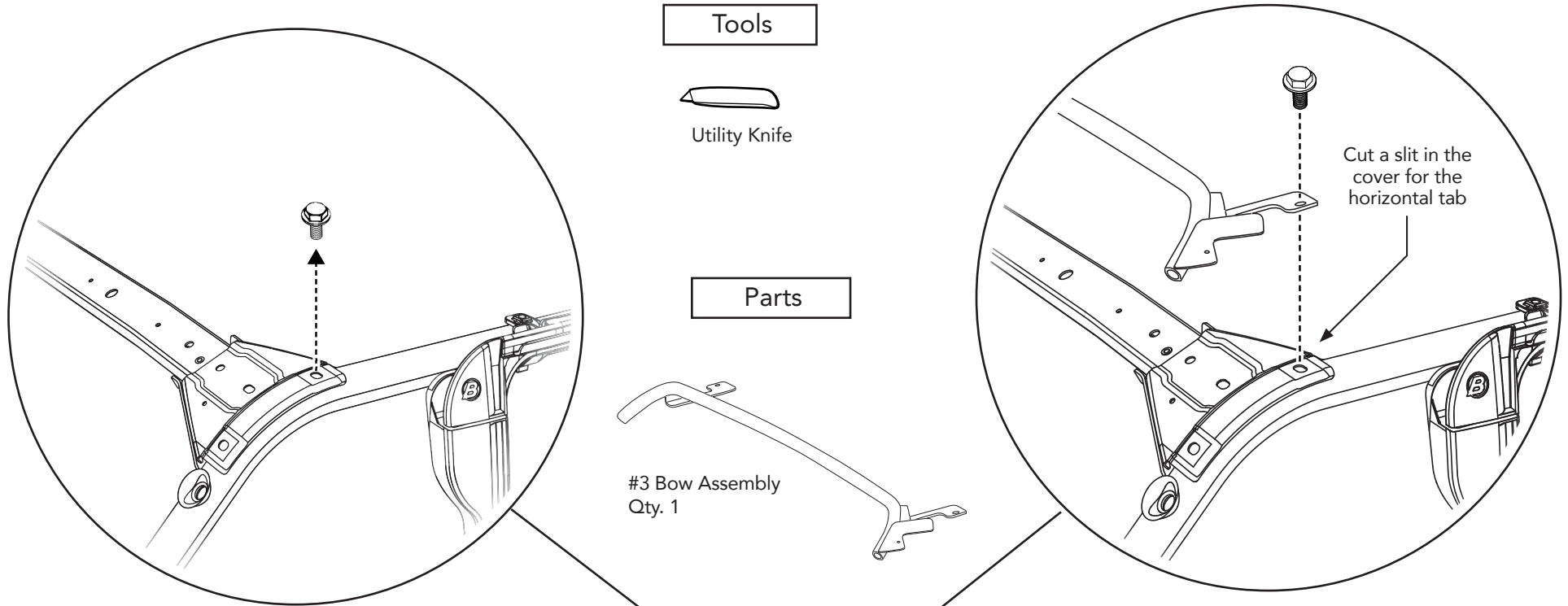

Unzip the sport bar cover over the rear cross bar, to expose the sport bar corner plates, and the factory-installed hex-head bolt on each side.

Remove the indicated hex-head bolt on each side of the sport bar.

Zip the sport bar cover closed.

Cut a slit in the sport bar cover over each bolt hole where you just removed the hex-head bolts.

Attach the #3 Bow Assembly to the sport bar, using the hex-head bolts you removed earlier.

The horizontal tabs on each side of the #3 Bow will slip through the slits in the sport bar, allowing you to access the threaded holes in the sport bar.

Tighten the bolt on each side.

Un zip the sport bar cover.

- ① Remove the rear bolt on the sportbar corner plate.
- ② Cut a slit in the sportbar cover.

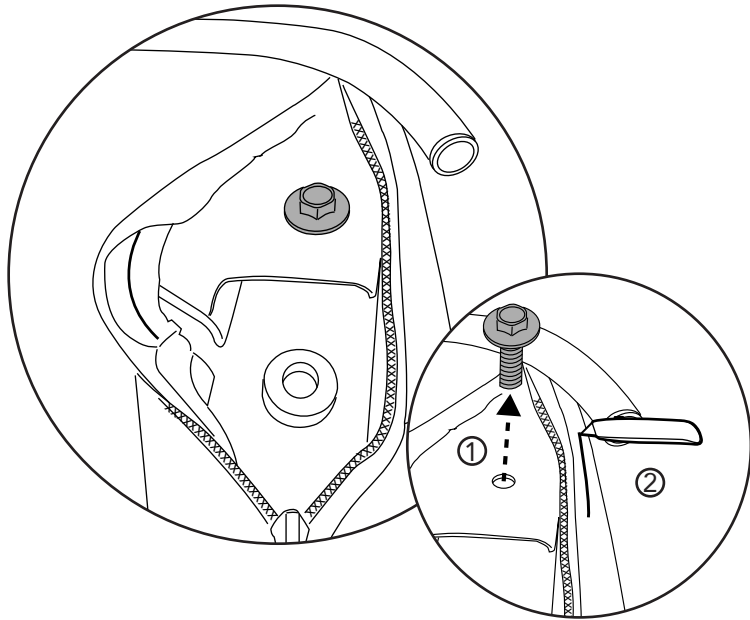

Tools



Utility Knife



Ratchet



13mm Socket

Parts

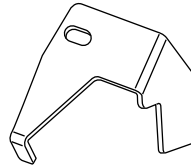

D Pillar Bracket
Qty. 1 per side

Place the tab of the D Pillar Bracket through the slit in the sport bar cover then place the bracket over the hole the bolt was removed and replace the bolt.

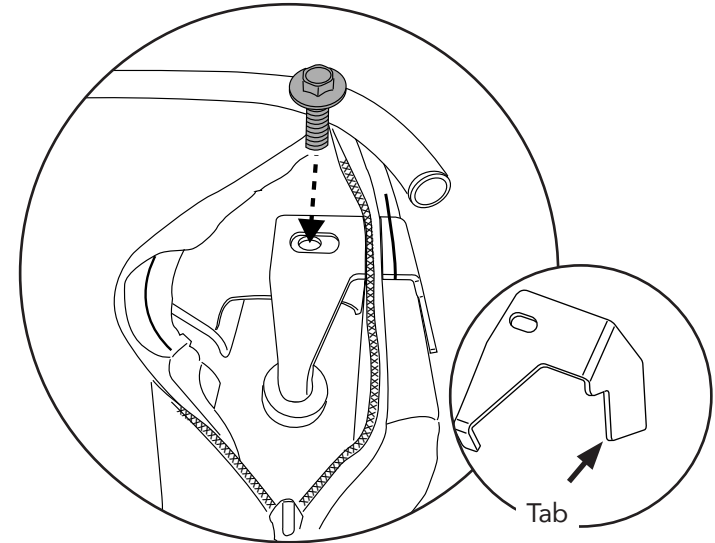

Zip up the sport bar cover and repeat these steps on the left side of the vehicle.

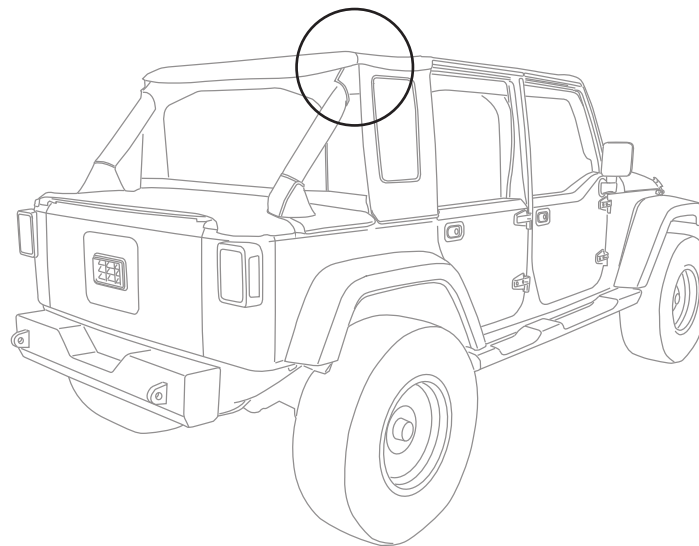

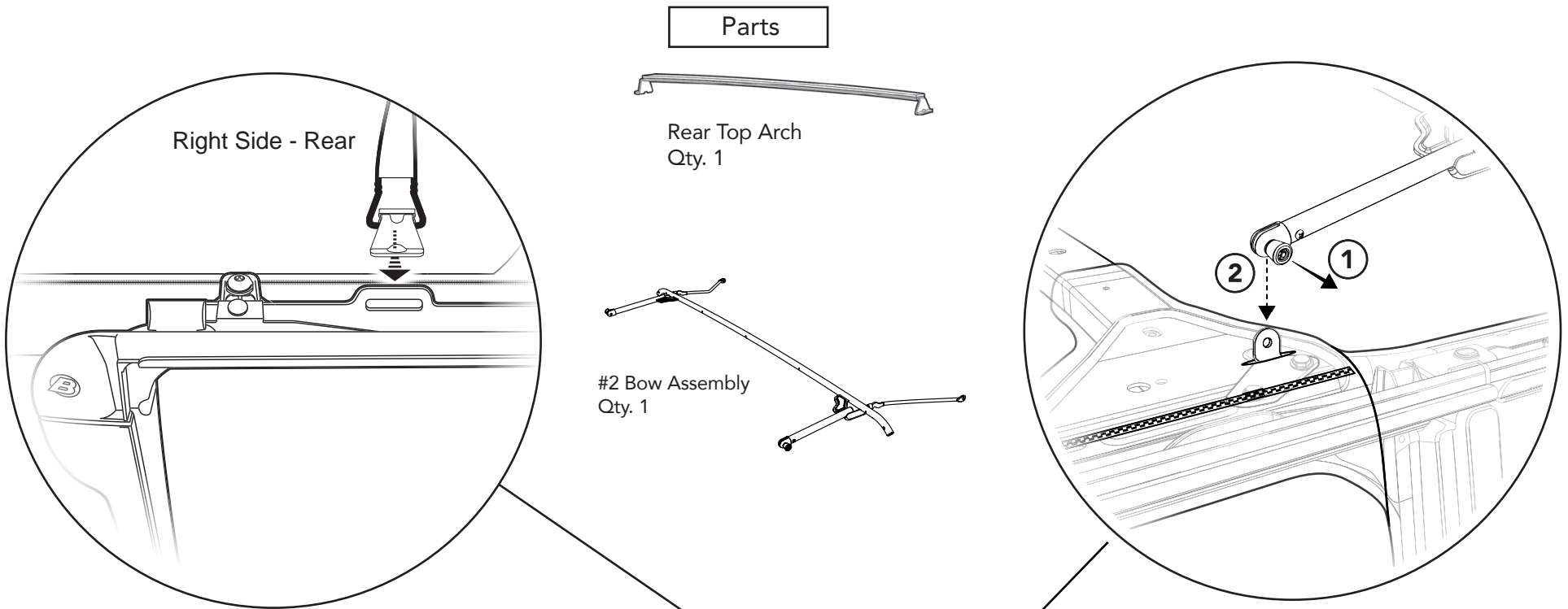

Insert one end of the Rear Top Arch into the slot in the middle of the Rear Door Rail on the opposite side of the Jeep from you.

Push the near end of the Top Arch inward while pushing up in the middle of the Top Arch to flex the Arch, so you can insert it into the slot on top of the Rear Door Rail on your side of the Jeep.

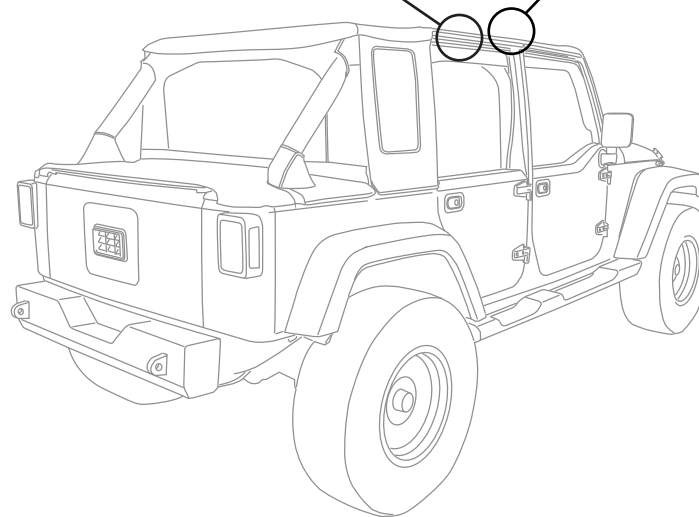

Attach #2 Bow to the #2 Bow Pivot Brackets on each side.

- 1 Pull out on the knob to release the spring-loaded catch on the #2 Bow rear legs, and
- 2 Slide the slotted end of the catch over the #2 Bow Pivot Bracket tab protruding from the sport bar cover.

Make sure that the spring catch snaps into place on each #2 Bow Pivot Bracket tab.

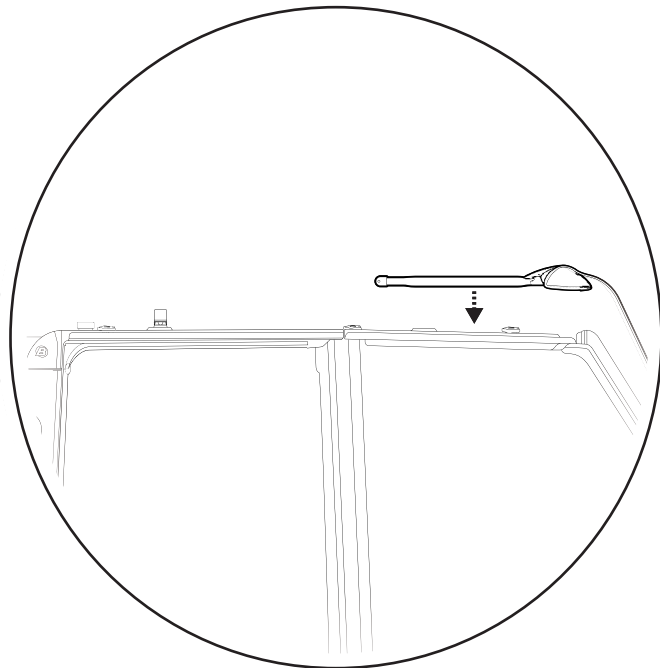

Lift the Header/Side Bow Assembly onto the top of the Jeep, with the Header sitting on top of the Jeep windshield, and the fabric draped forward over the Jeep hood.

You may want to protect the finish of the Jeep by putting a blanket across the Jeep Hood.

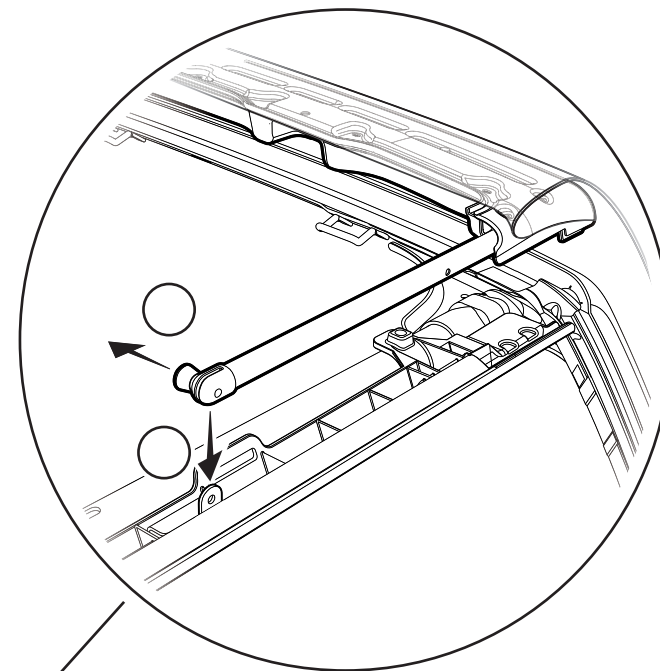

Attach the right Side Bow to the Right Sunrider Pivot Bracket.

- ① Pull out on the spring catch release knob.
- ② Slide the slotted end of the Side Bow over the vertical tab on the Sunrider Pivot Bracket, and release the knob, making sure that the catch snaps into place on the Pivot Bracket tab.

Repeat on the left side of the Jeep.

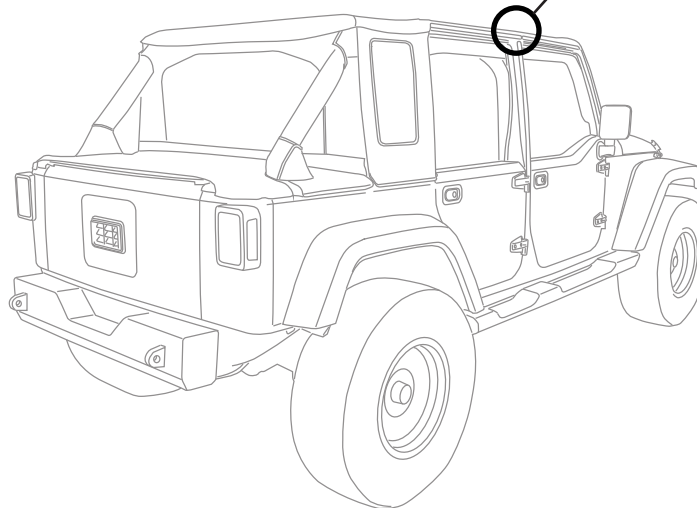

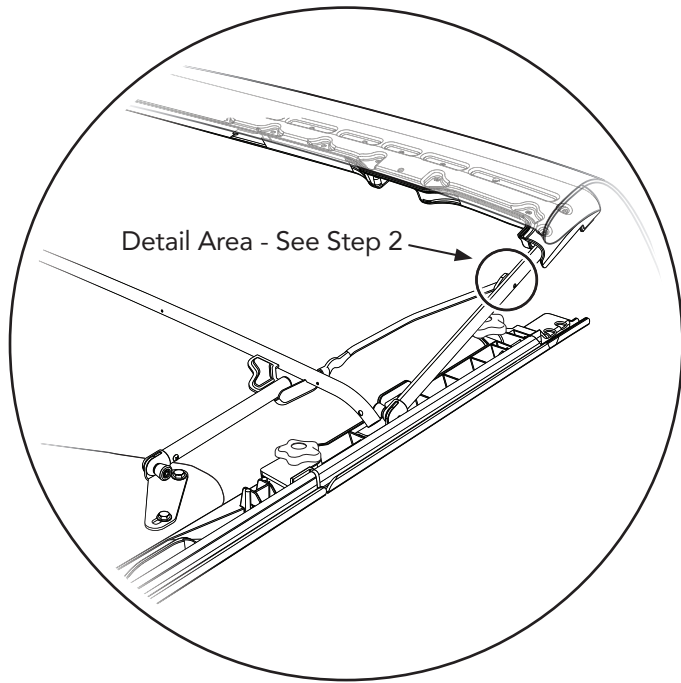

Lift the Side Bow/Header up and locate the hole in the Side Bow near the Header.

Using this hole in the Side Bow, attach the #2 Bow to the Side Bow.

Tools



Parts

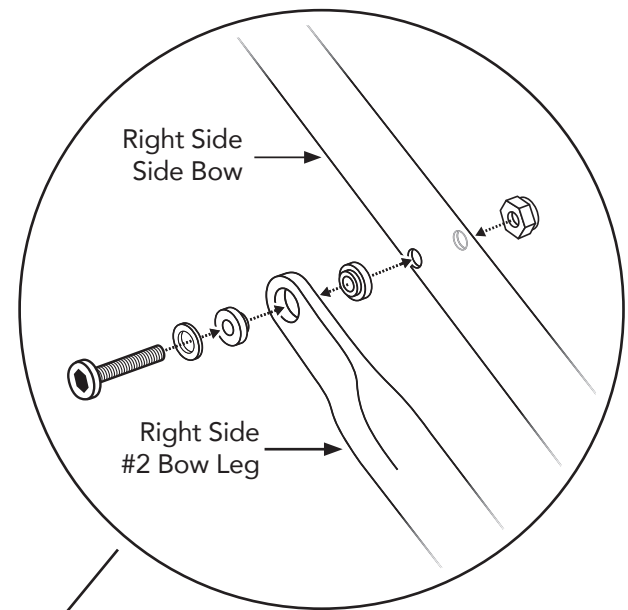
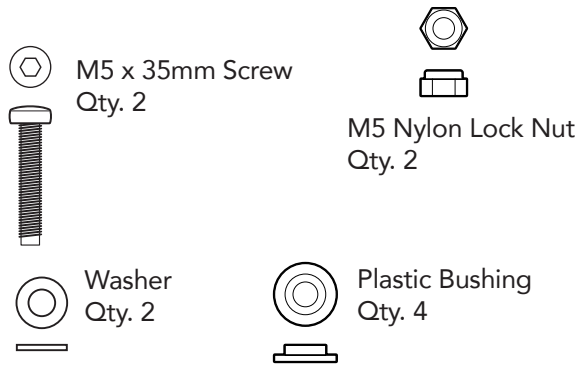

Secure the #2 Bow to the Side Bow using one (1) M5 x 35mm Machine Screw, two (2) Plastic Bushings, one (1) M5 Nylon Lock Nut and one (1) M5 Washer on each side of the vehicle.

The Plastic Bushings go on both sides of the flat portion of the #2 Bow leg.

The Nylon Lock Nut goes on the inboard side of the Side Bow.

NOTE: Do not overtighten, to avoid damaging the plastic bushings.

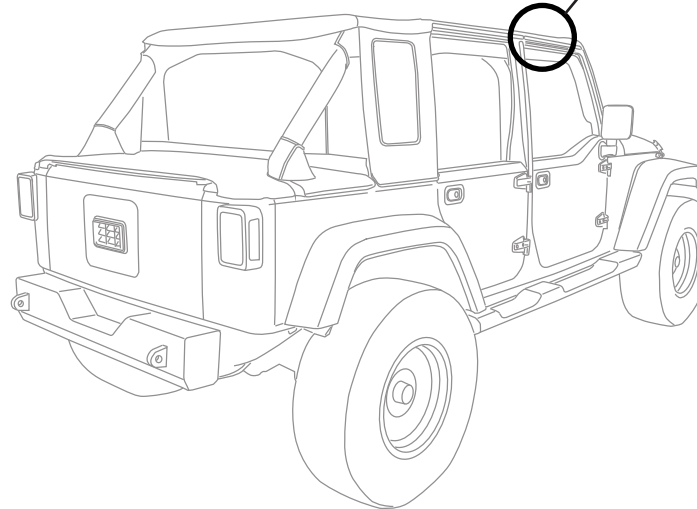

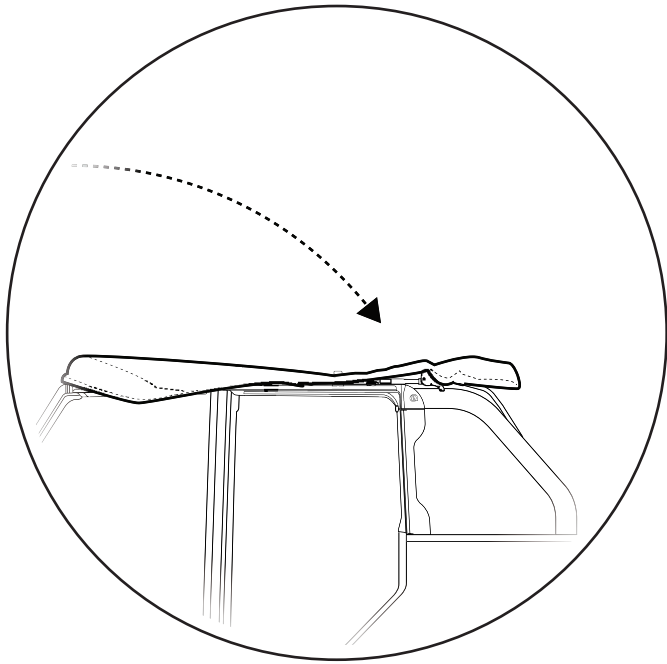

Lift the fabric and drape it back over the top of the Jeep, pulling it over the top of the #2 Bow, Top Arch and #3 Bow.

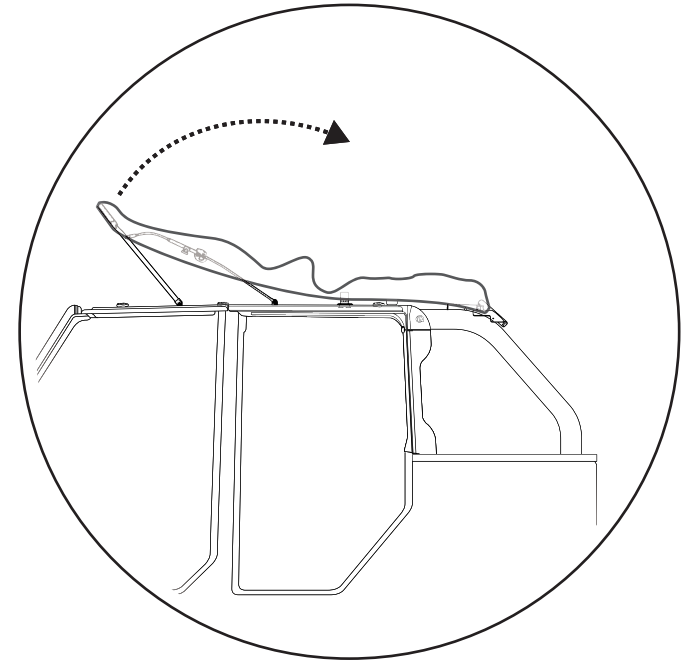

Fold the Sunrider back from the front pivot point, resting the front portion of the top on the rear portion.

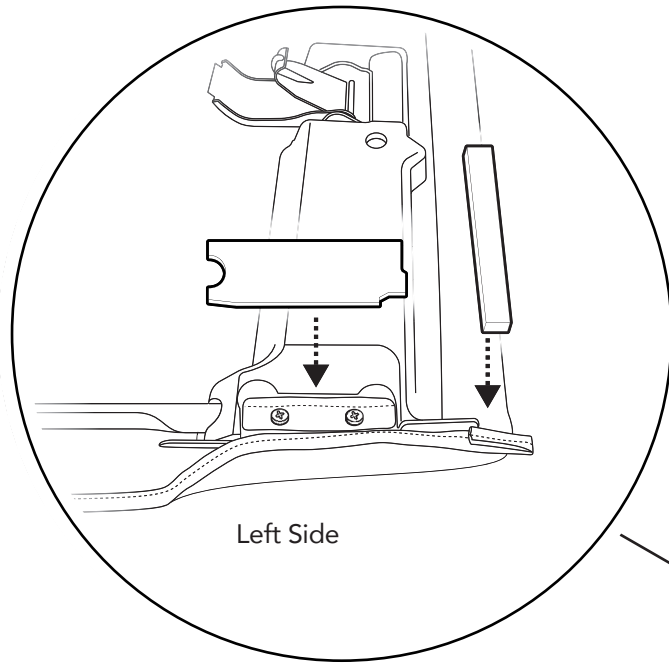

Parts

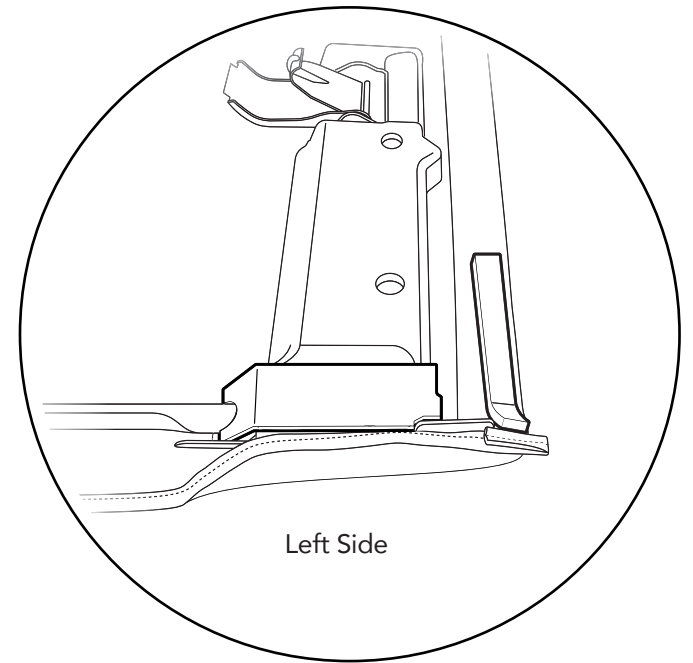
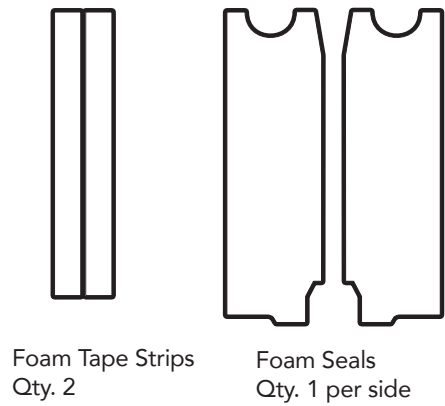

With the Sunrider folded back, locate the two (2) Foam Seals. Remove the protective liner from the back side of the left Foam Seal and place the Seal in the location shown above.

Repeat on the right side of the Header.

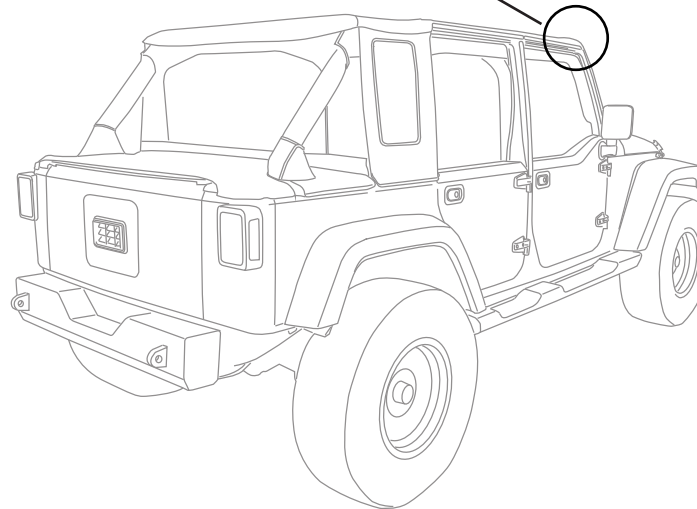

Remove the protective liner from the back side of one the Foam Tape Strips, and place the Strip in the location shown above, on the left side of the Header.

Repeat on the right side of the Header.

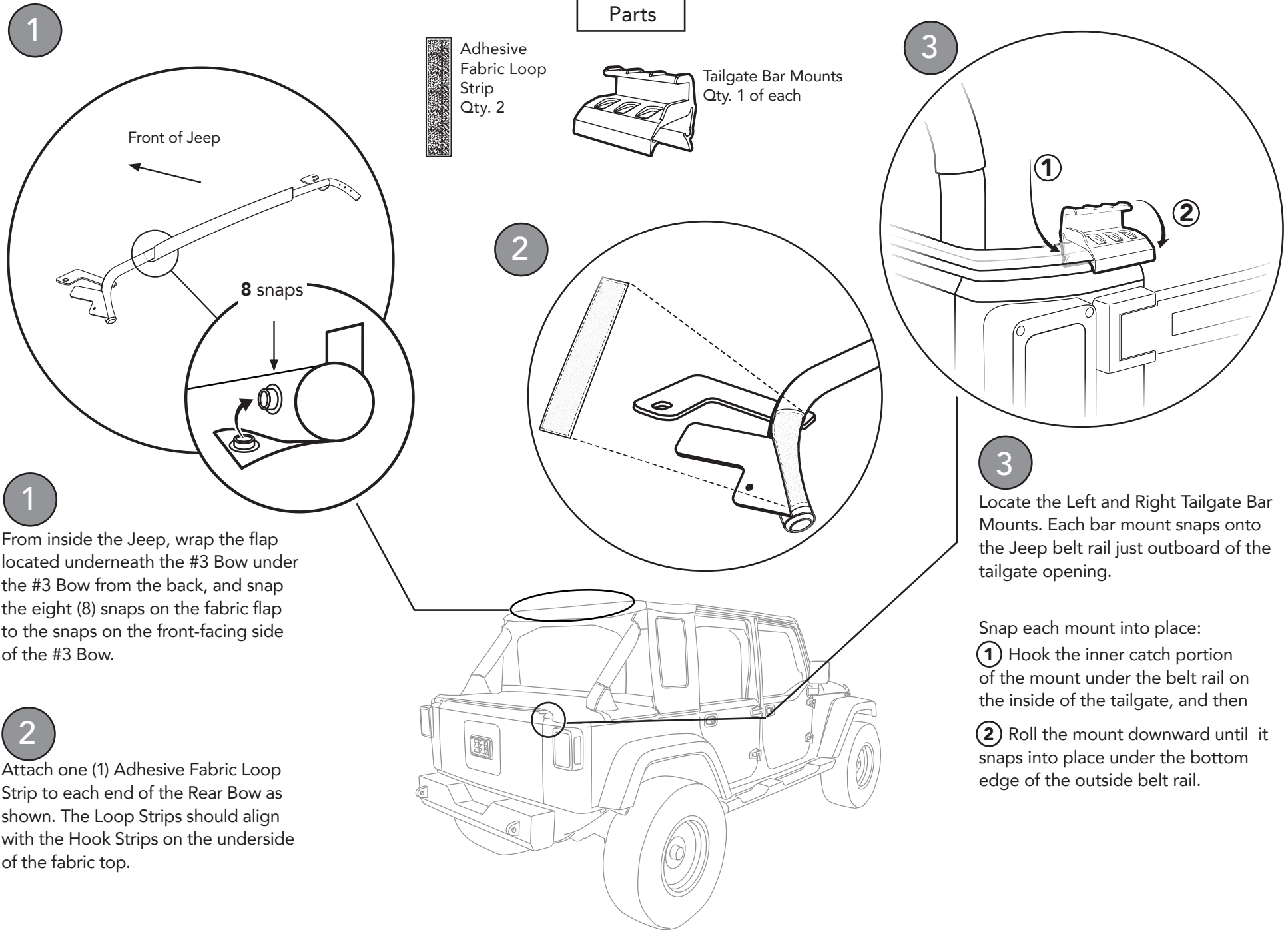

1 From inside the Jeep, wrap the flap located underneath the #3 Bow under the #3 Bow from the back, and snap the eight (8) snaps on the fabric flap to the snaps on the front-facing side of the #3 Bow.

2 Attach one (1) Adhesive Fabric Loop Strip to each end of the Rear Bow as shown. The Loop Strips should align with the Hook Strips on the underside of the fabric top.

- Parts**
- Adhesive Fabric Loop Strip Qty. 2
 - Tailgate Bar Mounts Qty. 1 of each

3 Locate the Left and Right Tailgate Bar Mounts. Each bar mount snaps onto the Jeep belt rail just outboard of the tailgate opening.

Snap each mount into place:

- 1** Hook the inner catch portion of the mount under the belt rail on the inside of the tailgate, and then
- 2** Roll the mount downward until it snaps into place under the bottom edge of the outside belt rail.

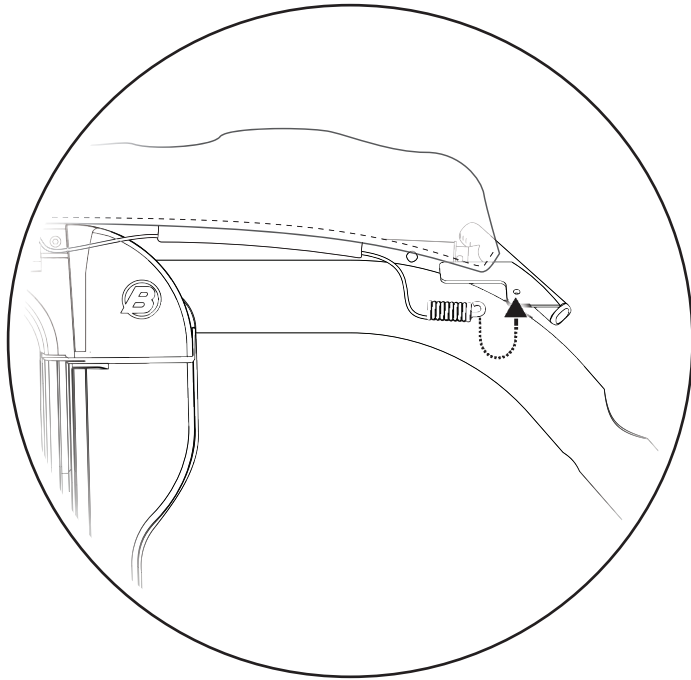

Tools



Vise-Grips

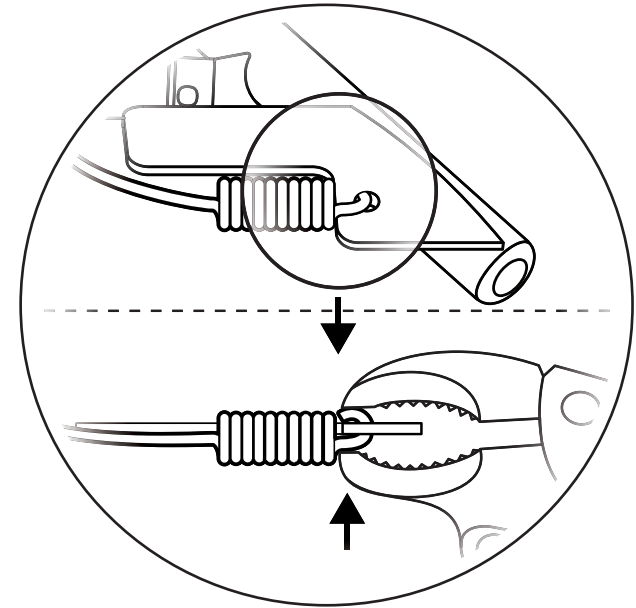

Attach the free end of the Cable Spring to the bottom hole in the #3 Bow corner plate, just above the bend in the rear leg of the sport bar.

Crimp the end of the spring where it passes through the hole in the #3 Bow corner plate, to prevent it from coming loose.

Repeat on the other side of the vehicle.

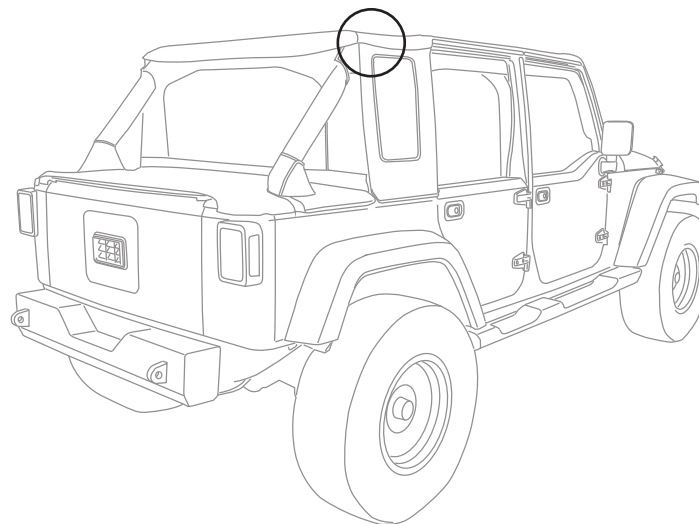

Starting on the side of the duster without the pull tabs, roll the Duster up loosely. The side of the Duster with the pull tabs is the front edge.

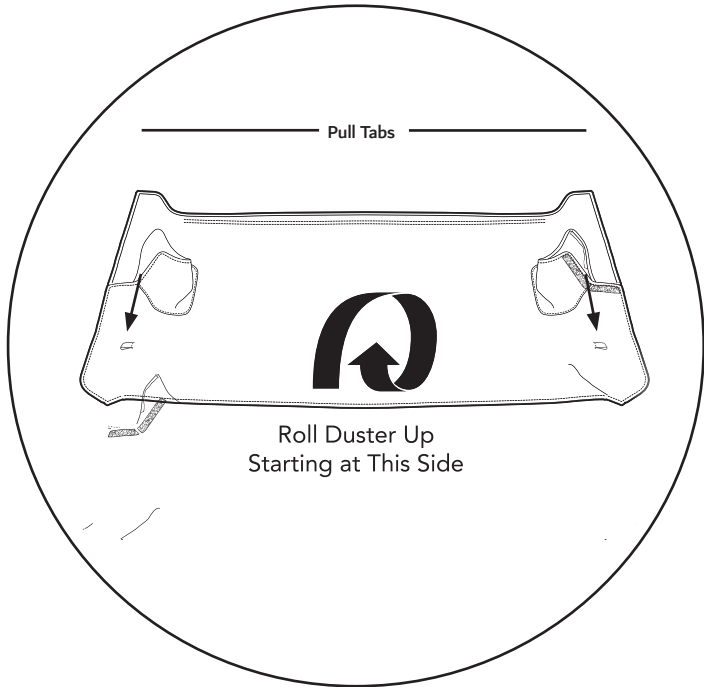

Parts

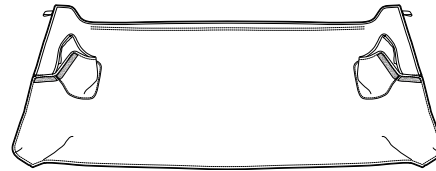

Duster
Qty. 1

With the Duster loosely rolled up, slide the P-Extrusion along the exposed front edge of the Duster into the top slot of the Extruded Aluminum Bow, using the slot in the Bow that is on top of the arch and facing up.

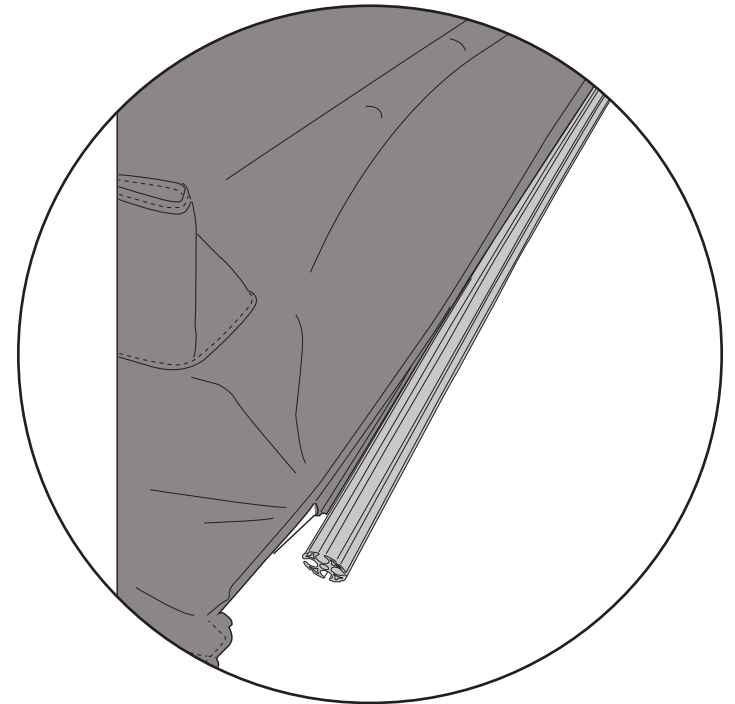
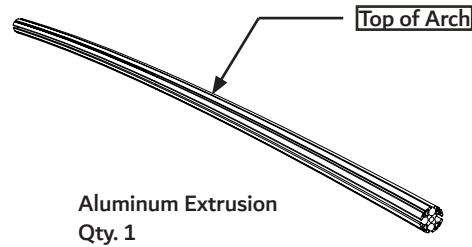

NOTE: Aluminium Extrusion has arch. The Duster should be in the top part of the arch.

Slide the sewn in P-extrusion into the front channel of the Aluminium Extrusion.

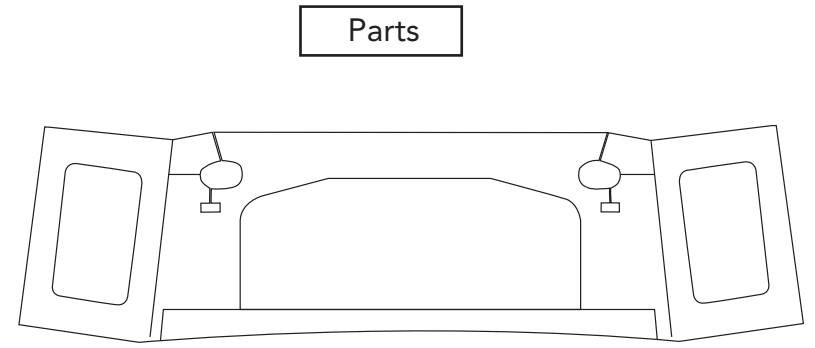
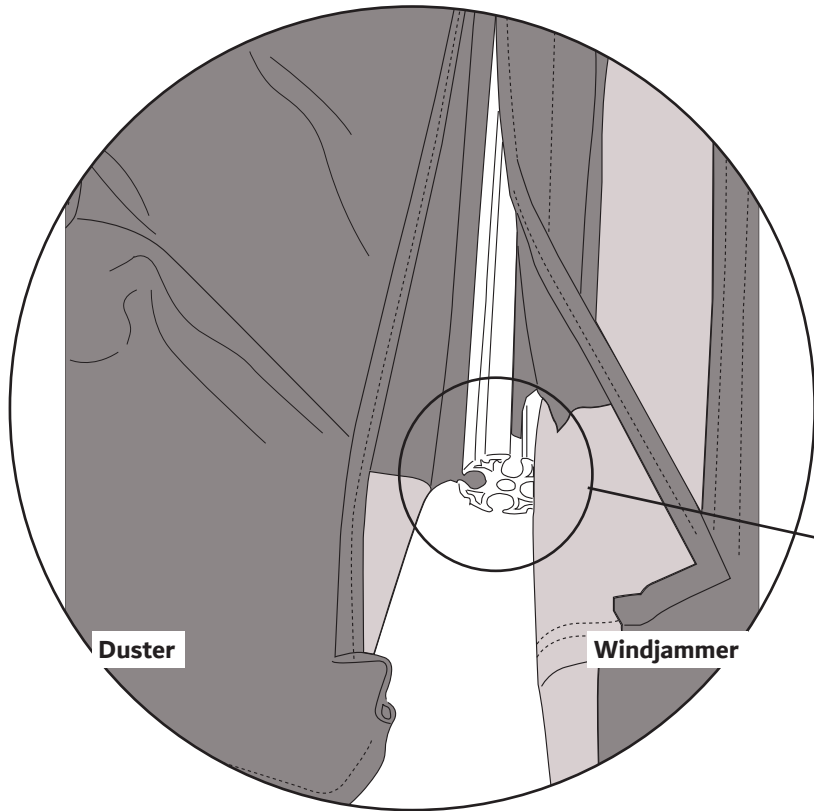

Windjammer Assembly

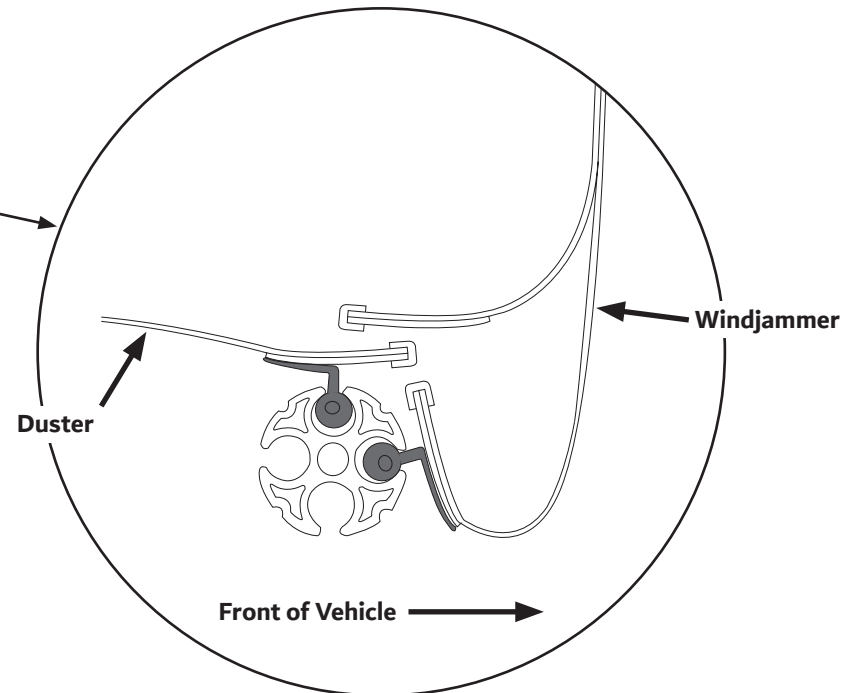

Slide the Rubber Retainer located at the top (Center Section) of the Windjammer into the Plastic "C" channel located at the rear of the Top (Under the rear flap) until the Windjammer is centered on the Top.

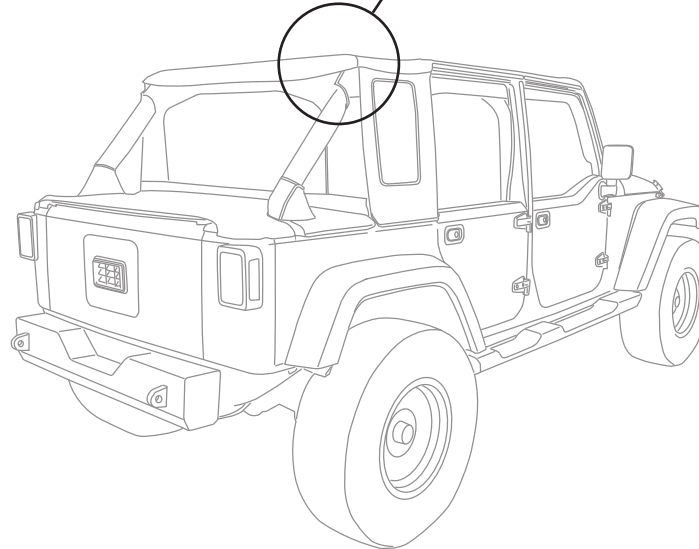
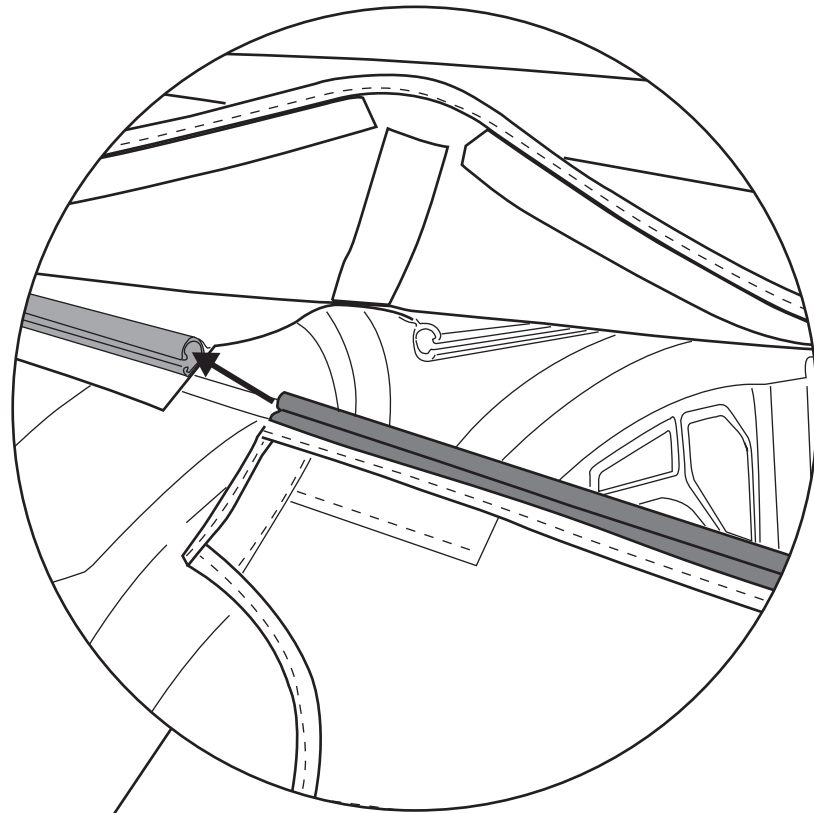

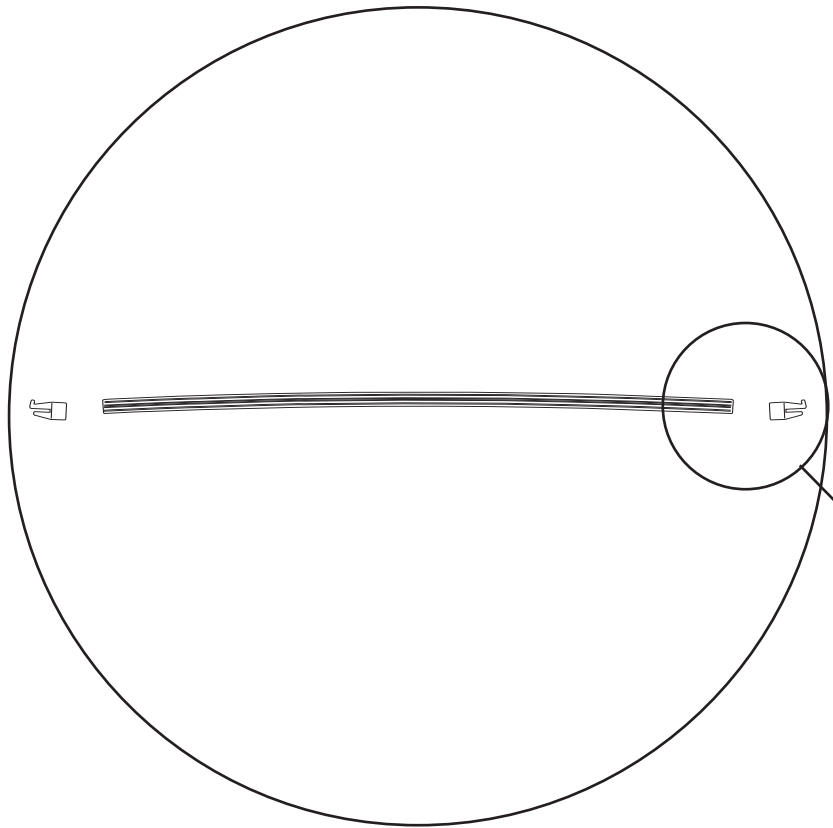

Place the Plastic End Caps on the passenger side of the Aluminium Extrusion and on the driver side. The internal ribs inside the round opening of each end cap will slide into the slots on the top and bottom of the aluminum extrusion.

Parts

Plastic End Cap - Left
Qty. 1

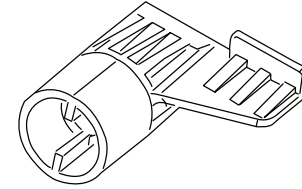

Plastic End Cap - Right
Qty. 1

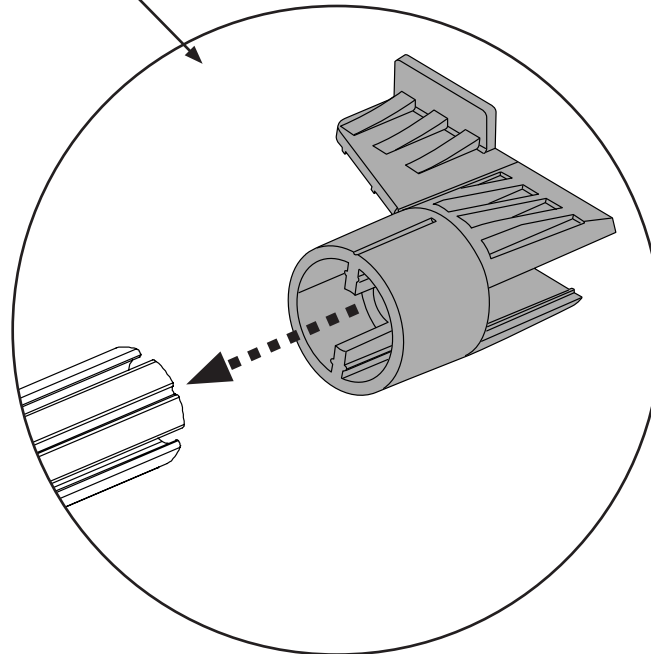
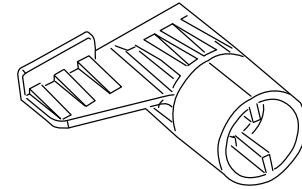

NOTE: The Wing must go towards the front of the vehicle with the Tab pointing up.

Fold both rear seats forward. (Refer to Owners Manual)
Set End Cap as far rearward on the driver side then set the other end cap as far forward as possible on the passenger side. You will have to move the lower leg of the Rear Door Rail away from the body to get the passenger side clip started.

NOTE: You must place the Extrusion and Fabric Assemblies through the Seat Belts to properly install the Duster and the Windjammer.

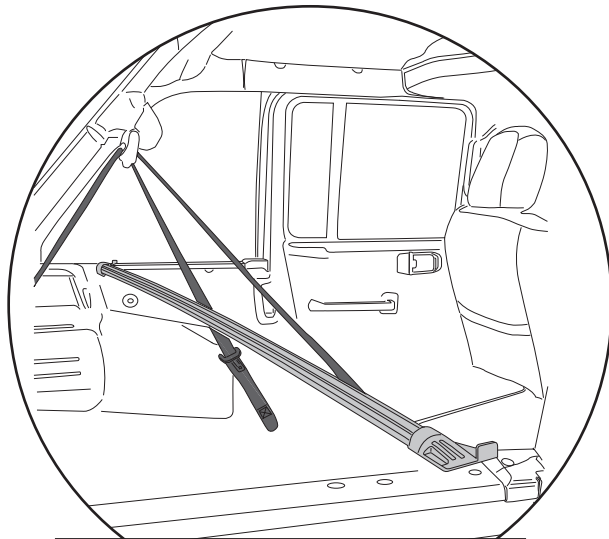

Fabric not shown for illustration purpose only.

Slide the Bow End forward (Driver Side) and Rearward (Passenger Side) until you reach the 13 1/4 inch dimension from the front of the Extrusion to the front edge of the Rubber Seal at the top and rear of the door opening.

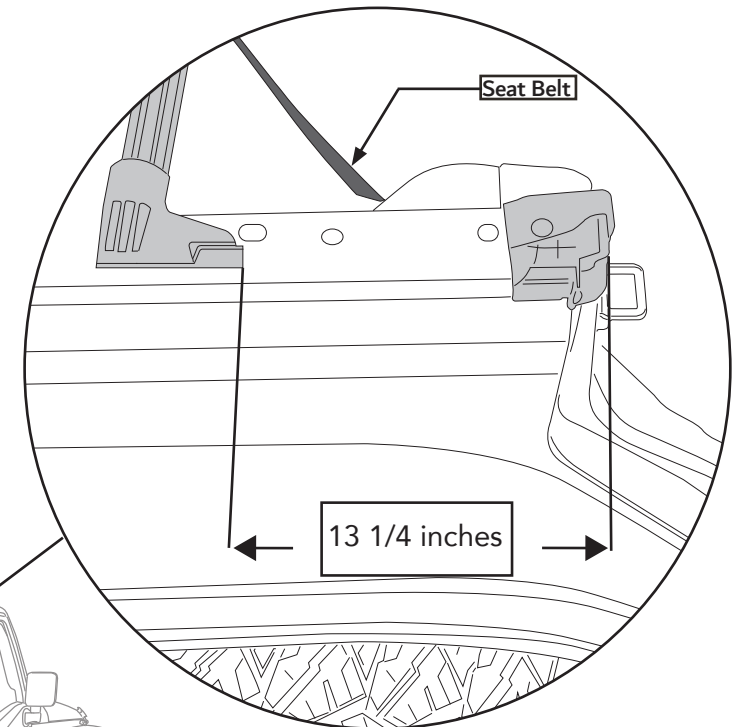

NOTE: 13 1/4 inches is the starting point for the Bow End location. You will be able to move the Bow Ends forward or backwards for small adjustments as necessary..

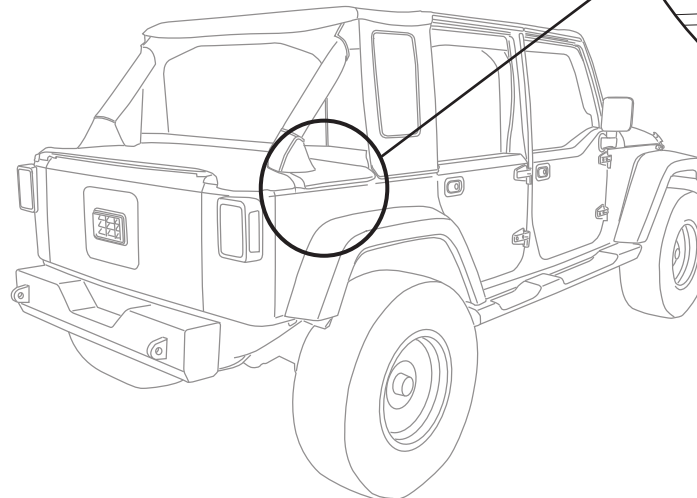

1

Insert the top of the D Pillar Bow onto the Bow Support Bracket and push it all of the way up.

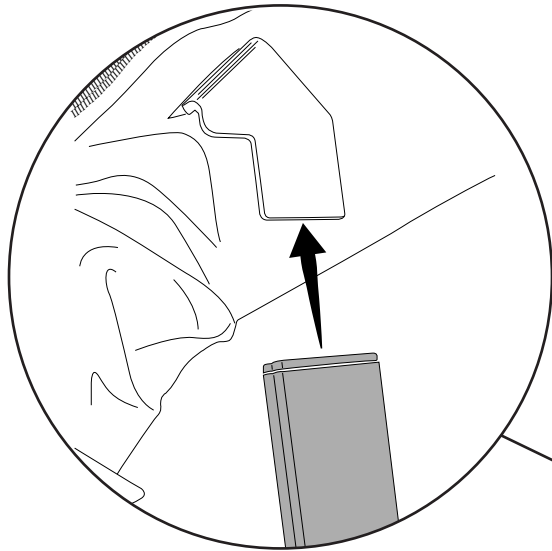

Parts



Bow D Pillar
Qty. 2

2

Align the D Pillar Bow with the tab on the End Cap then pull the D Pillar bow down onto the tab.

Repeat the steps on left side of the vehicle.

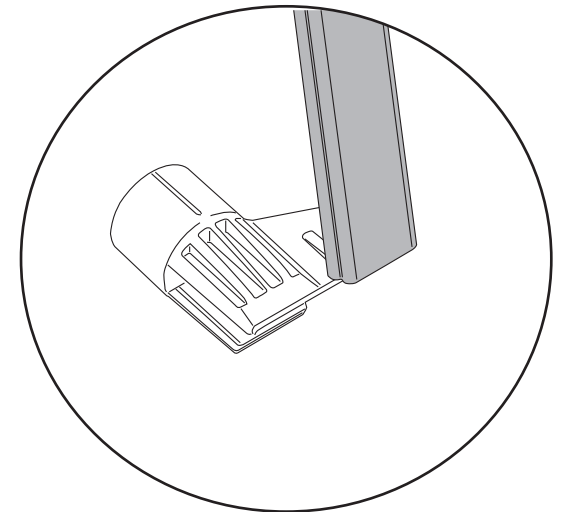
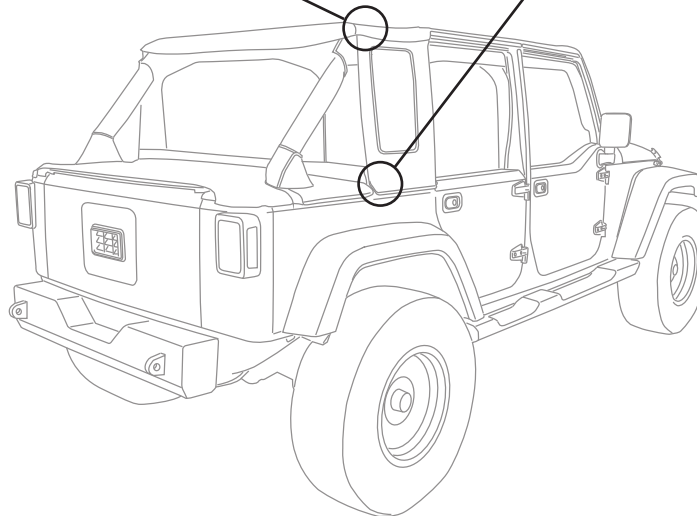
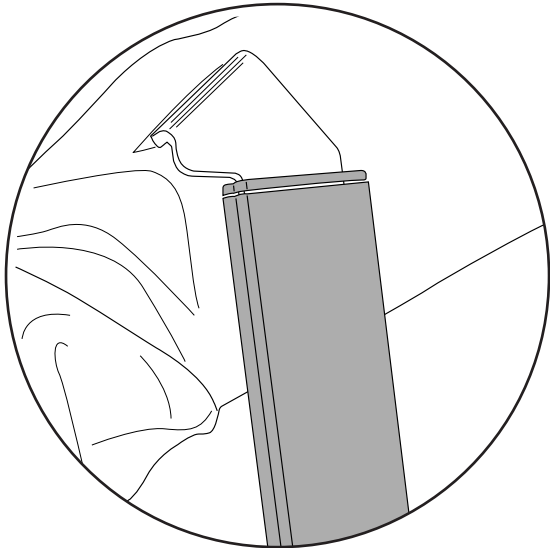
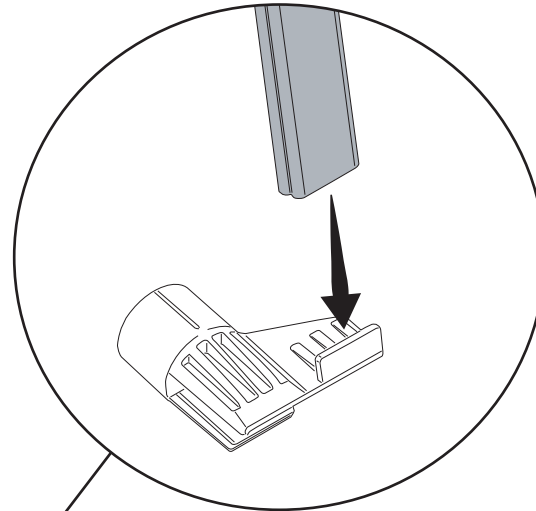

Attach the Tailgate Bar to the sewn-in P-Extrusion rail on the underside of the rear of the Duster. Slide the Tailgate Bar all the way across the "P" extrusion. (As it was on the rear window of the Trektop)

Secure the Tailgate Bar with attached Duster to the Tailgate Bar Retainers. Press the Tailgate Bar into the receiver on each Tailgate Bar Retainer.

NOTE: The bulb seal on the Tailgate bar must hang below the bar and face rearward for the tailgate to touch it.

Parts

Tailgate Bar
Qty. 1

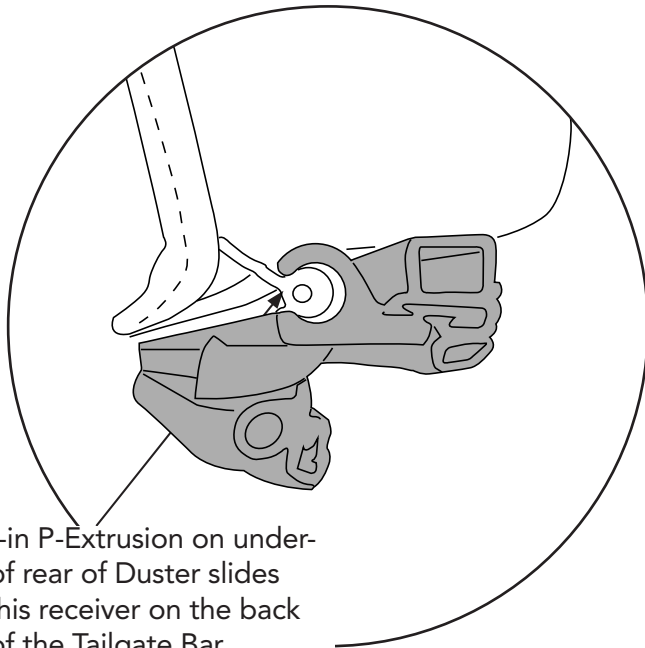
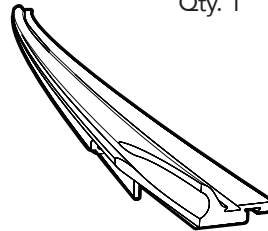

Sewn-in P-Extrusion on underside of rear of Duster slides into this receiver on the back side of the Tailgate Bar.

Duster attached to Tailgate Bar

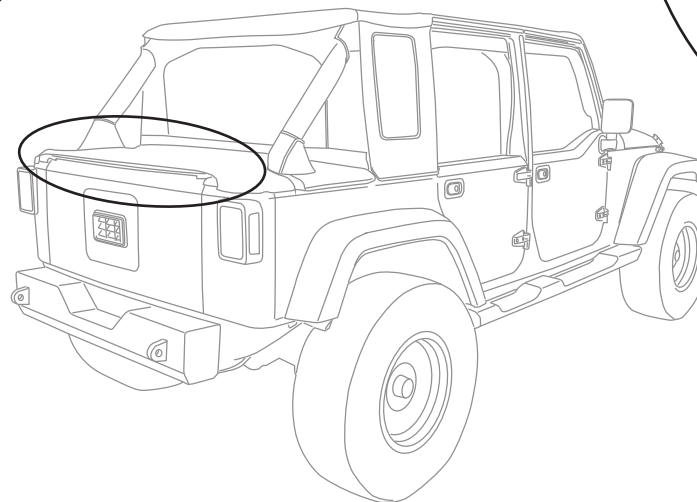
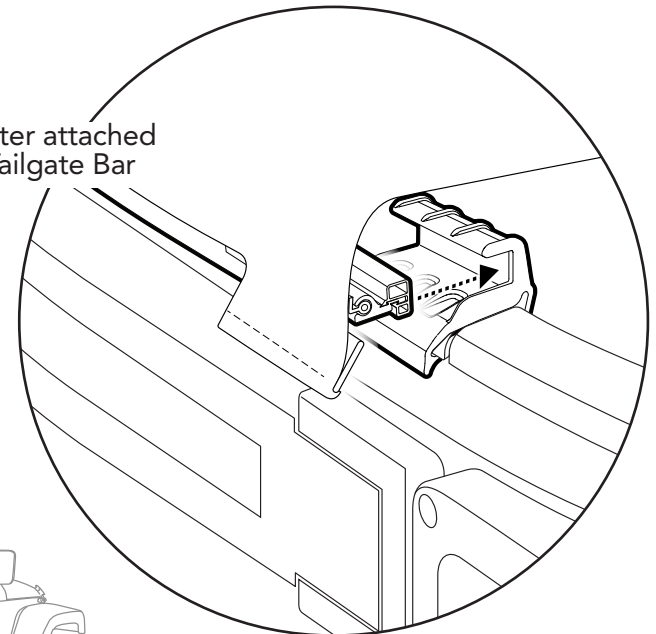

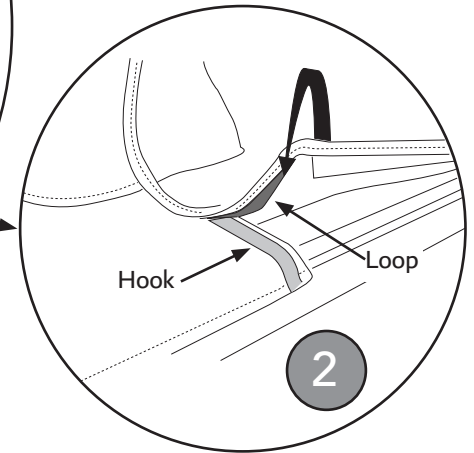
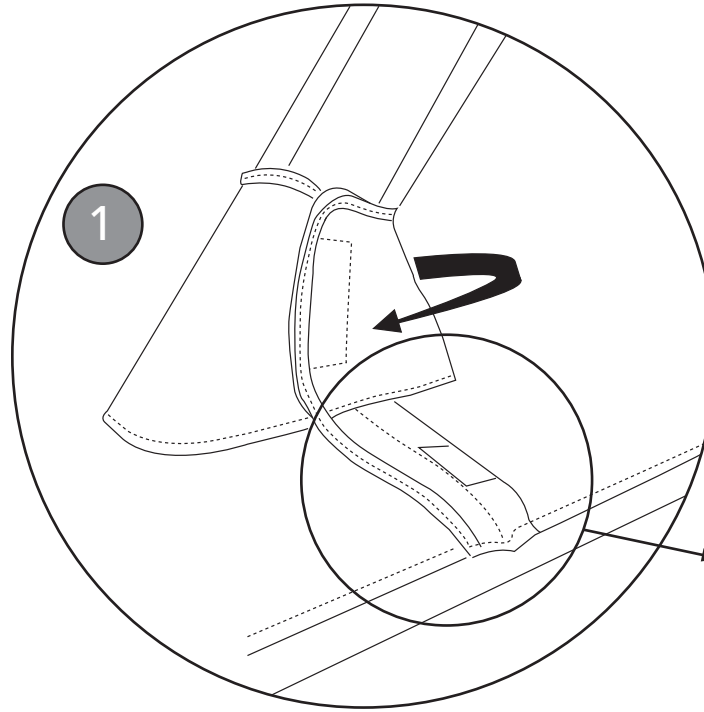
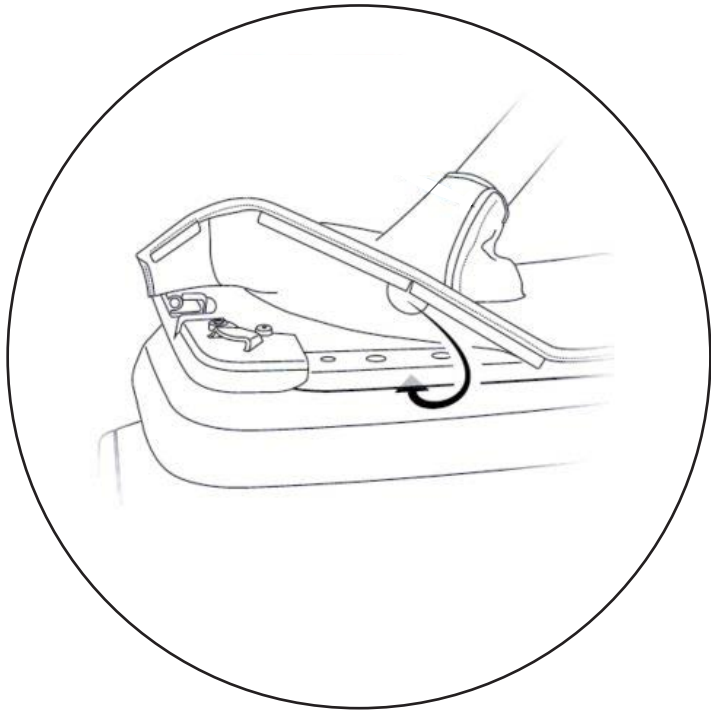

Tuck the plastic tabs along the left and right edges of the Duster underneath the Jeep belt rail, working from back to front. Make sure to tuck the straight tabs as well as the semi-circular tabs under the belt rail.

Tuck all side plastic tabs under the belt rail, from back to front, and then tuck the plastic tabs at the rear corners under the belt rail.

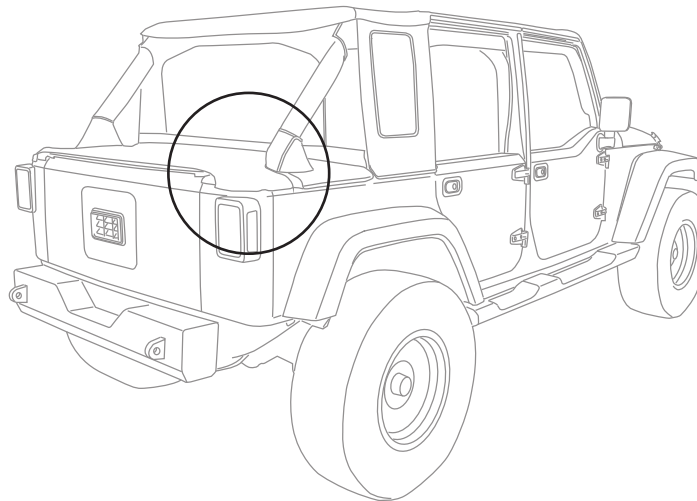

- 1 Wrap the hook-&-loop sleeves around the sport bar downtubes, and attach hook-&-loop strips together snugly.
- 2 Press the Hook and Loop together along the side of the Duster cover

Repeat on left side of vehicle.

1

Slide the "C" Channel Retainer located along the top of the Side Panel onto the plastic retainer located on the top.

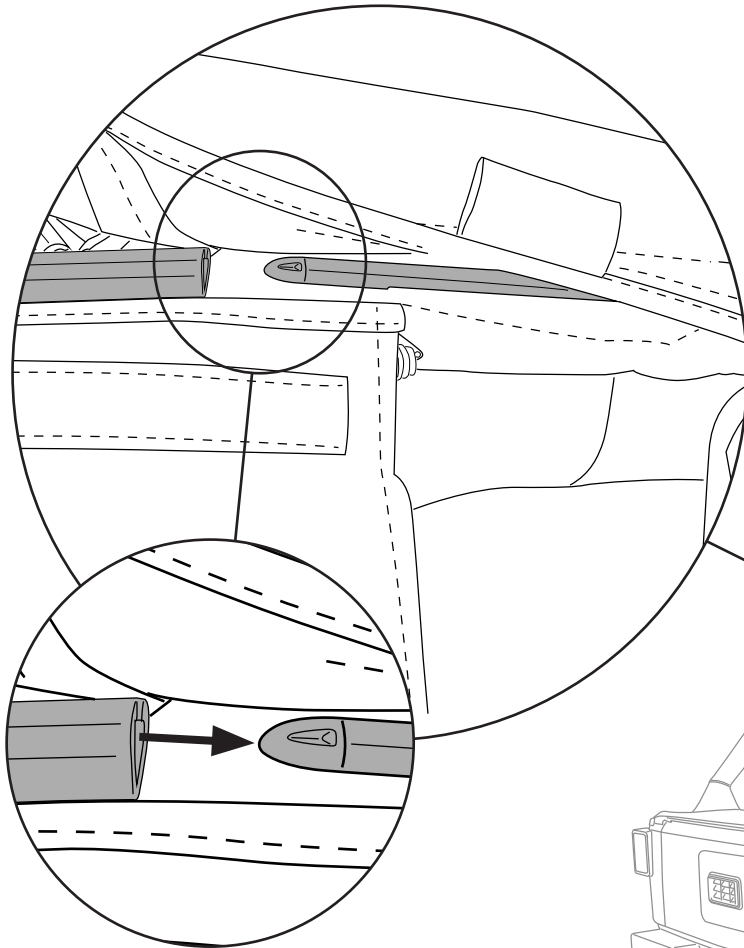

2

Locate the sewn-in plastic strip along the front edge of the Side Panel. Tuck this plastic strip into the vertical channel along the outside face of the Right Rear Door Rail.

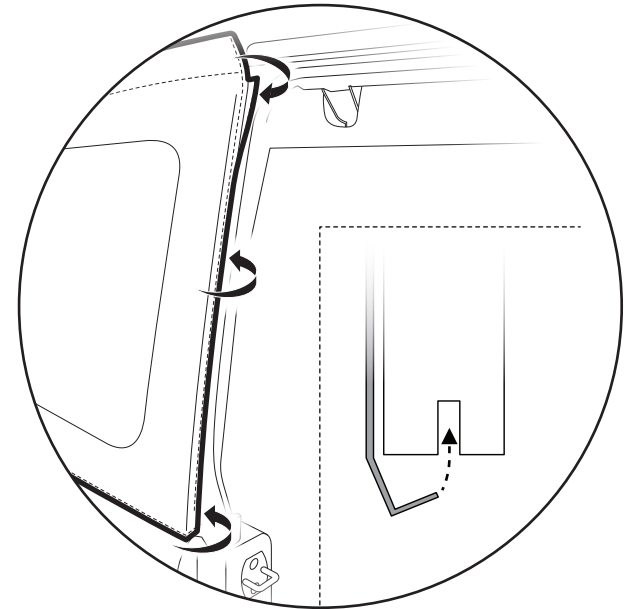

Repeat on left side of vehicle.

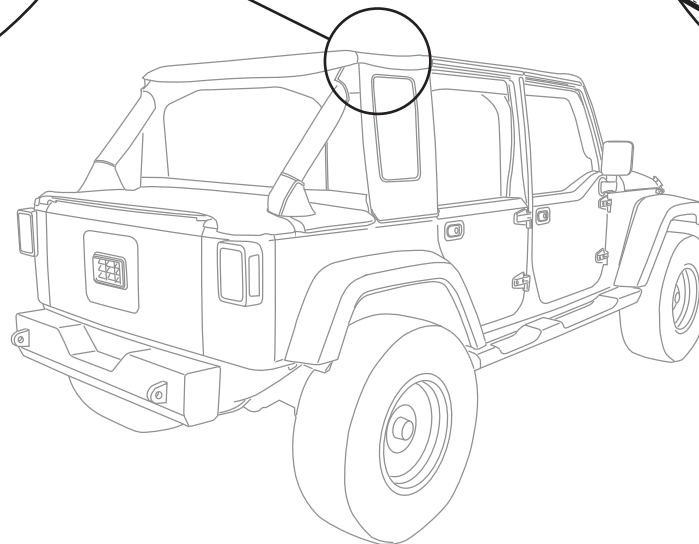

3

Tuck the plastic strip along the bottom edge of the Right Side Panel under the Jeep belt rail, by rolling it up underneath the belt rail, beginning at the rear, and working your way forward.

NOTE: Make sure you tuck the tab on the front edge of the Duster under the bottom edge of the Side Panel.

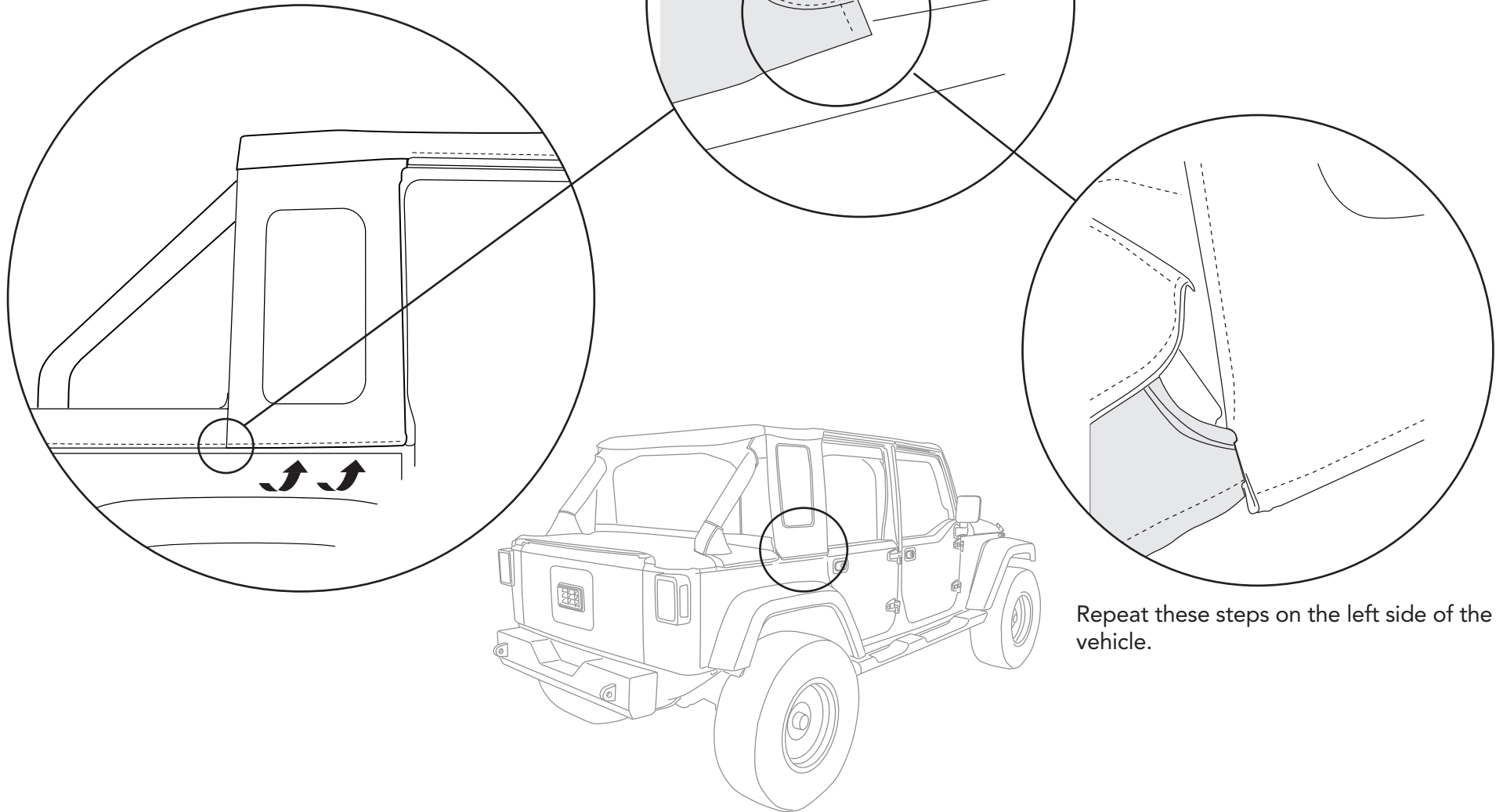

Repeat these steps on the left side of the vehicle.

Secure the Hook and Loop flaps along the top of the Windjammer that go over and under the sport bar.

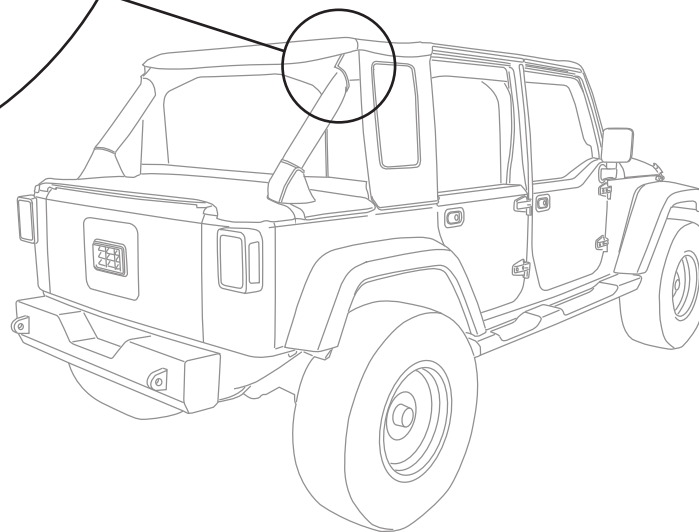
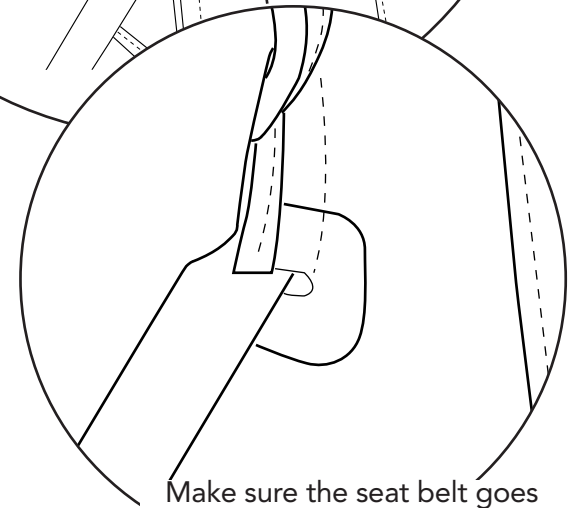
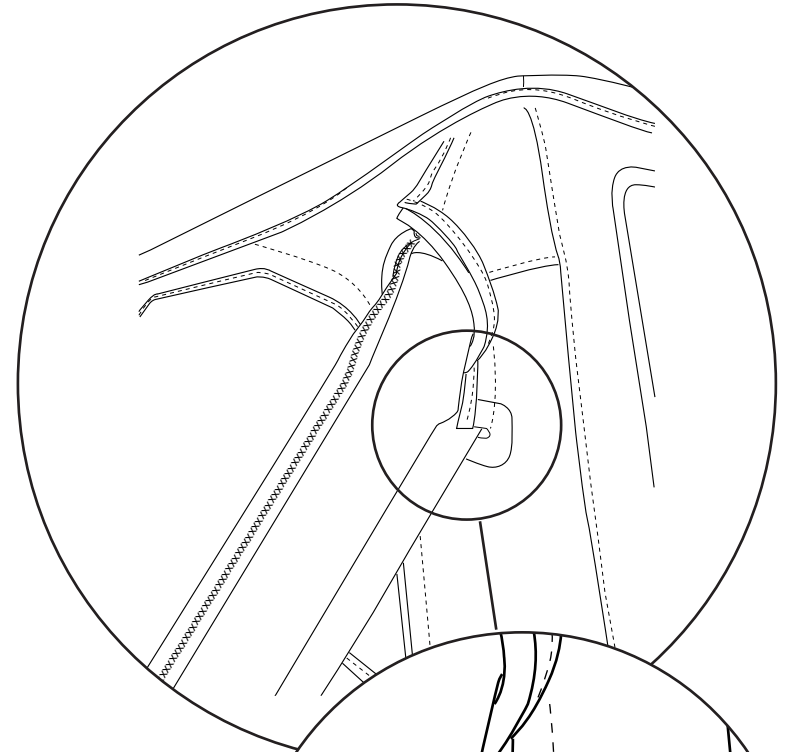
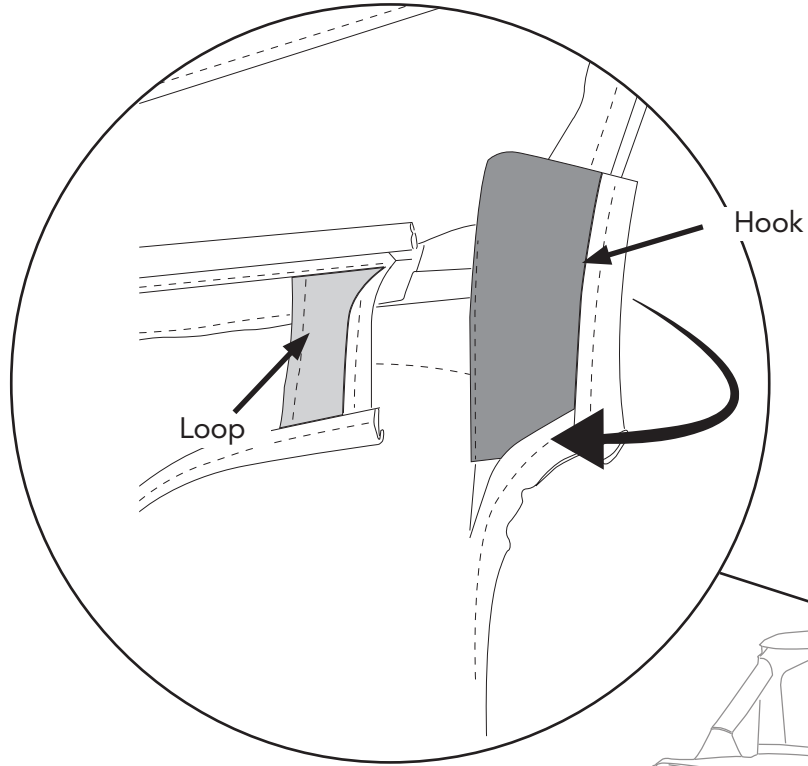

Repeat these steps on the left side of the vehicle.

Secure the Hook and Loop along the side edge of the Top to the top edge of the Windjammer.

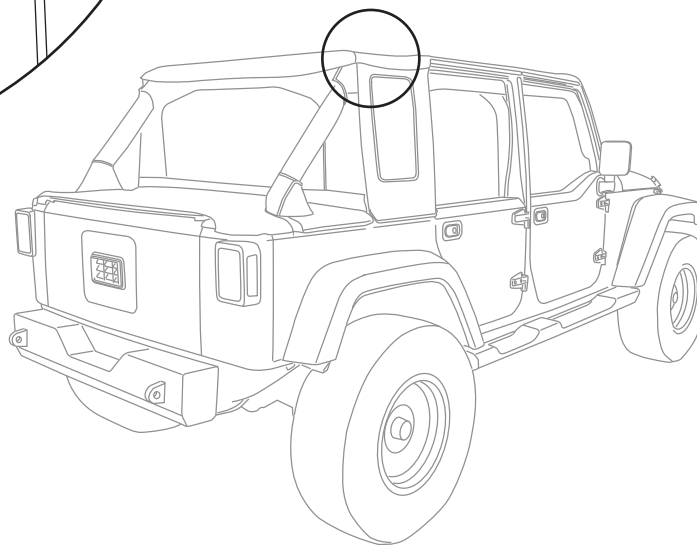
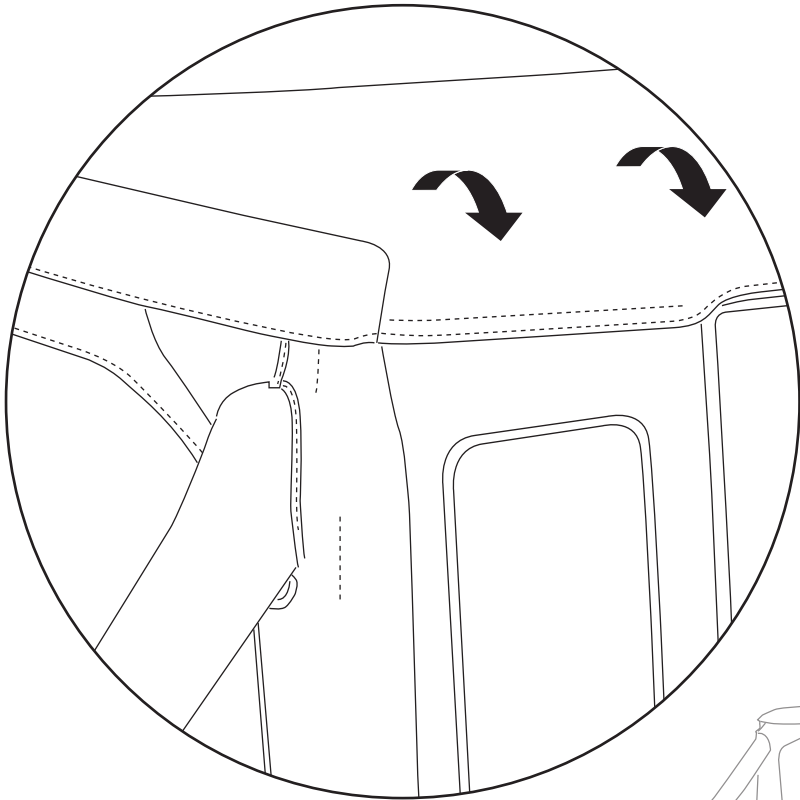



Care and Maintenance of your Bestop Product

Your Bestop product is made of the finest materials available. To keep it looking new and for the maximum possible wear, it will need periodic cleaning and maintenance.

Fabric: The fabric should be washed often using soap, warm water and a soft bristle brush. Rinse with clear water to remove all traces of soap. Bestop recommends using Bestop Cleaner (part no. 11201-00) and Bestop Protectant (part no. 11202-00) for Vinyl fabric and Bestop Twill Protectant (part no. 11207-00) for Twill fabric. Bestop Cleaner and Bestop protectant are specially formulated to provide a total cleaning and protection system. Bestop Cleaner safely removes the toughest stains, will not harm vehicle finishes, is biodegradable and environmentally friendly. Bestop Protectant protects against UV-fading, cracking and hardening, and repels dust, grease, dirt and mildew.

Windows: Keep windows clean to avoid scratching. **DO NOT** use a brush on the windows! Wash with a water-soaked cloth or sponge and a mild dishwashing detergent. Bestop recommends Bestop Vinyl Window Cleaner (part no. 11203-00), which safely cleans and protects vinyl windows and helps prevent UV damage. **NEVER WIPE THE WINDOWS WHEN THEY ARE DRY.** Be careful when cleaning snow or frost from the vinyl windows since they are easily scratched and may crack at low temperatures. **DO NOT** roll the sides or rear window in cold weather. The windows become stiff and will crack. Cracks caused by misuse in cold temperatures are not covered under warranty.

Water: Seeping through at the seams may be stopped by applying 3-M Scotchgard® on the inside of the seams.

Snaps: Keep snaps cleaned and lubricated with silicone to help prevent snaps from sticking to the studs. If a snap does become stuck to a stud, use a screwdriver and **GENTLY** pry apart to prevent permanent damage to the snap or the top fabric.

Zippers: Keeping zippers cleaned and lubricated with Bestop's Zipper Cleaner (part no. 11206-00) will help prevent damage and keep the zippers in smooth working condition. If a zipper opens behind the slider, the slider may have been spread apart. This problem can usually be repaired by using an ordinary pair of pliers to bring the sides back into parallel. Return slider to the end of the zipper in the normal Open position. Squeeze lightly at first and test the zipper. If the zipper continues to remain open squeeze more firmly with the pliers and try the zipper again. Repeat this procedure until the zipper operates correctly.

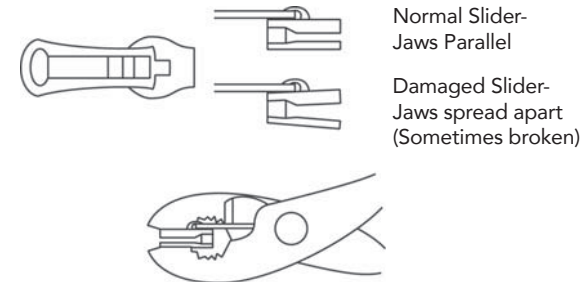

For Bestop Warranty Information, Please go to;
<https://www.bestop.com/help/warranty-information/>

