



BLUE OX

BX2632

2011-2013 Ford Explorer

With Adaptive Cruise Control & Eco Boost
Installation Instructions

Baseplate Installation Instructions

Please read BOTH these Installation Instructions and the General Instructions before attempting to install or operate this equipment.

Serial Number

1. Blue Ox® towing products and accessories are intended to be installed by Blue Ox® Dealers who are familiar with our products and have the necessary equipment and knowledge to do “fit work”. When necessary Blue Ox® Dealers can be found at www.blueox.com or by contacting our Customer Care Department at (402) 385-3051.

Attachment Tab Height: 18 1/2”

Attachment Tab Width: 20”

2. Many Blue Ox® baseplates are designed to use existing holes and hardware to mount the baseplate to the towed vehicle. Even though bolts are there, do not assume they are adequate for baseplate mounting. Always use hardware supplied in the hardware kit and existing hardware specified in the Baseplate Installation Instructions.

Bolt Torque Specifications

Torque in Foot-Pounds for Metric Bolts

Bolt Size	Grade 8.8	Grade 10.9
6MM	6	8
8MM	16	22
10MM	31	40
12MM	54	70
14MM	89	117

Confirm the towability and pre-towing procedures for your vehicle with the owner’s manual or contact the vehicle’s manufacturer for specific towing procedures.

Bolt Torque Specifications

Torque in Foot-Pounds for Inch Bolts

Bolt Size	Grade 5	Grade 8
1/4”	10	14
5/16”	19	29
3/8”	33	47
7/16”	54	78
1/2”	78	119
5/8”	154	230

Do not use the towed vehicle for storing luggage, equipment, etc. This may cause you to exceed the towing capacity of the tow bar, baseplate, and its accessories.



If the front of your vehicle looks different than this, call us at (402) 385-3051.

! WARNING

Failure to read and follow these instructions could result in separation of the towed vehicle from the tow bar, causing property damage, loss of towed vehicle, personal injury or death.



BX2632

2011-2013 Ford Explorer

With Adaptive Cruise Control & Eco Boost

Installation Instructions

Baseplate Installation Instructions

Ref. No.	Qty.	Part No.	Description
1.....	2	61-4604	1/2"-13 Nut Plate with 10" Wire
2.....	1	61-6867	BX2632 Baseplate
3.....	1	62-3468	Attachment Tab with Hole
4.....	2	101-5822	4 Way Connector Adapter
5.....	1	102-7056	Breakaway Bracket
6.....	1	201-0050	1/4"-20 x 3/4" Hex Head Bolt, Grade 5, ZP
7.....	2	201-0051	1/2"-13 x 1-1/2" Hex Head Bolt, Grade 5, ZP
8.....	2	201-0071	1/4"-20 x 1" Hex Head Bolt, Grade 5, ZP
9.....	2	201-0192	#10-32 1/2" Round Slotted Screw
10.....	1	201-0514	3/4"-10 x 1-3/4" Hex Head Bolt, Grade 5, ZP
11.....	4	201-0553	1/4"-20 x 1/2" Hex Wshd. Screw, Type F TCS, ZP
12.....	2	202-0047	#10-32 Hex Nut
13.....	2	202-0069	1/4"-20 Hex Flange Whiz Lock Nut, ZP
14.....	1	202-0074	3/4"-10 Flange Whiz Lock Nut, ZP
15.....	1	202-0102	1/4"-20 Hex Nut with Nylon Insert, ZP
16.....	2	203-0001	1/4" Flat Washer, ZP
17.....	2	203-0012	1/2" Lock Washer, ZP
18.....	1	203-0014	3/4" Lock Washer, ZP
19.....	2	203-0054	#10 Lock Washer, ZP
20.....	2 (not shown).....	226-0049	36" Class IV Safety Cables
21.....	2 (not shown).....	229-0512	1/2" Quicklink, ZP
22.....	1 (not shown).....	290-0437	Black Receiver Cap
23.....	1 (not provided) ..	293-1339	Breakaway Switch
24.....	1 (not provided) ..	294-0805	4 Pin Connector
25.....	1 (not provided) ..	294-0902	6 Pin Connector

Tools Required

8MM Socket	Hammer
13/32" Drill Bit	11MM Socket
13MM Socket	25/32" Drill Bit
LOCTITE Red	1 1/8" Socket
Reciprocating Saw	Flat Screwdriver
Utility Knife	10MM Socket
Torque Wrench	17/32" Drill Bit
Tape Measure	3/4" Socket
Drill	Large Vise Grip
Phillips Screwdriver	

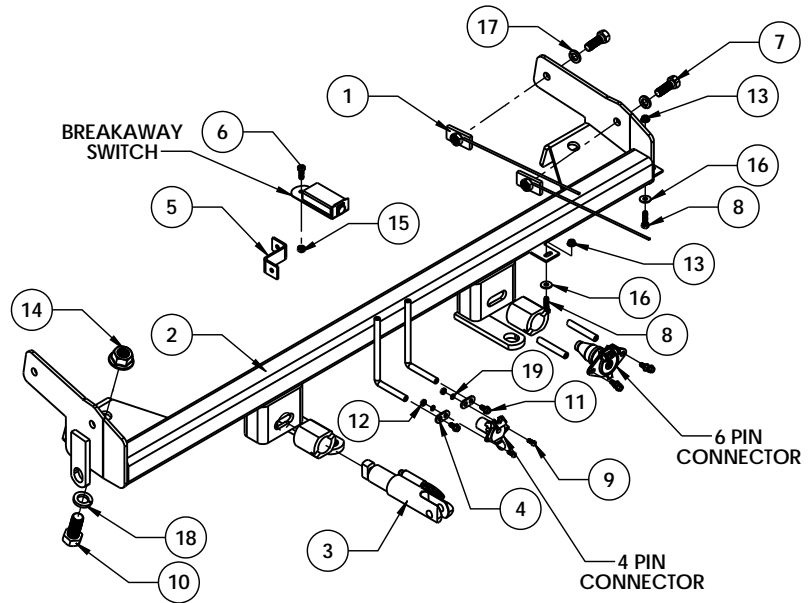

Important:

Use only genuine factory replacement parts on your baseplate. Do NOT substitute homemade or non-typical parts. If a bolt is lost or in need of replacement, for your safety and the preservation of your baseplate, be sure to use a replacement bolt of the same grade. In most cases it will be Grade 5. Please reference the parts list above. Replacement parts may be ordered through your nearest Blue Ox® dealer or distributor, or call our Customer Care Team at (402)385-3051. Failing to follow and/or altering these installation instructions in either installation or required equipment will void the manufacturer's warranty.



Baseplate Installation Instructions

BX2632 2011-2013 Ford Explorer With Adaptive Cruise Control & Eco Boost Installation Instructions

Attachment Tabs: Motorhome mount tow bars are recommended for use with this baseplate. Due to the design of the removable tabs, the RangeFinderII, Ambassador and Acclaim tow bars can not be used. Adapters, except the BX8833 and BX88151, can not be used with this baseplate.

Instruction Notes: The front fascia, windshield washer reservoir, speed control and the bumper are removed for the baseplate installation. The bumper will not be reinstalled. Trimming of the air dam and the frame rail are required. Drilling is required.

The dimensional variations between otherwise identical vehicles can be considerable. Although the baseplate was designed for easy installation, it may be necessary to tailor the baseplate slightly to compensate for auto manufacturer's tolerances. These minor adjustments may include filing a hole slightly, bending electrical rods or bending end plates.

The BX8848 Diode Wiring Kit is recommended for this vehicle.

Confirm the towability and pre-towing procedures for your vehicle with the owner's manual or contact the vehicle's manufacturer for specific towing procedures.

Do not use the towed vehicle for storing luggage, equipment, etc. This may cause you to exceed the towing capacity of the tow bar, baseplate, and its accessories.

Installation Instructions

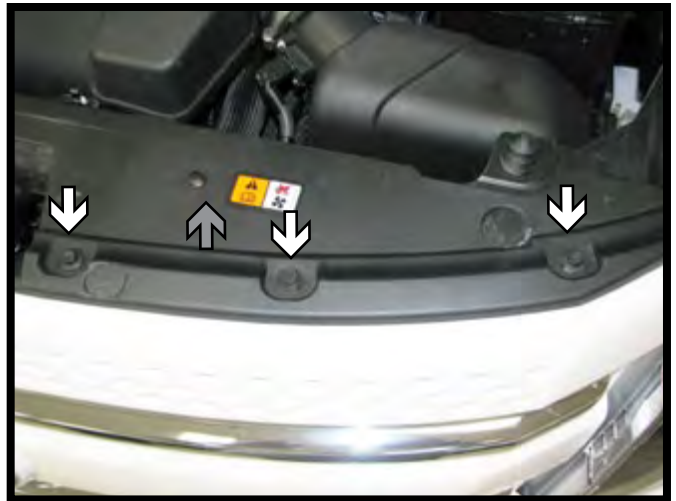

1. Using a 10MM socket, remove three bolts (white arrows) from the black plastic cover on the top side of the fascia. Also remove one push pin (gray arrow). Do this to both sides of the vehicle. On the passenger side, there are four bolts to remove. Set bolts and pushpins aside to be reinstalled later.



2. In front of the tire, using a Phillips screw driver, remove the four pushpins. Do this to both sides of the vehicle. Set pushpins aside to be reinstalled later.



Baseplate Installation Instructions

BX2632

2011-2013 Ford Explorer

With Adaptive Cruise Control & Eco Boost

Installation Instructions



3. Just forward of the front tire, on the fascia's corner, pry loose the protective rubber edging, remove one Phillips screw with a Phillips screwdriver. Do this on both sides of the vehicle. Set the screws aside to be reinstalled later.



4. Just forward of the front tire pull the cover back, remove one screw with a Phillips screwdriver. Do this to both sides of the vehicle. Set screws aside to re-install later.



5. Using an 8MM socket remove three bolts under the fascia corner, in front of the tire. Do this to both sides of the vehicle. Set bolts aside to be reinstalled later.



6. Using an 8MM socket remove the three metric bolts from the front of the fascia, located under the vehicle going across. There is one on each side and one in the middle, two are shown. Pull fascia corners down, then forward to release. Disconnect electrical connections. Set the fascia and the metric bolts aside to be reinstalled later.



Baseplate Installation Instructions

BX2632

2011-2013 Ford Explorer

With Adaptive Cruise Control & Eco Boost

Installation Instructions

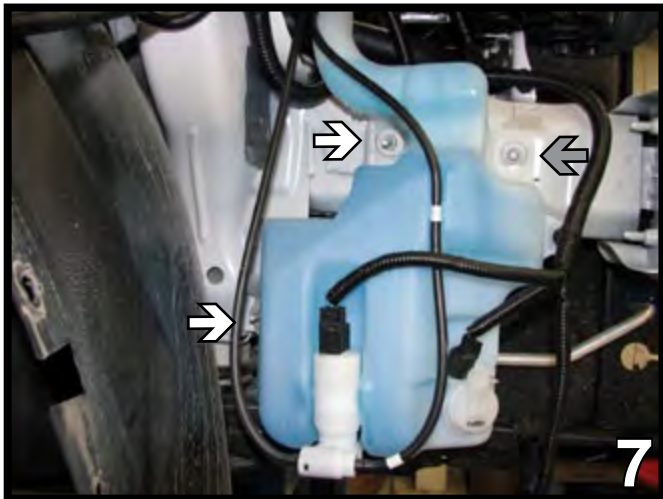

7. Using an 8MM socket (gray arrow), remove the bolt on the top. Using an 11MM socket, remove the two bolts on the sides (white arrows). Disconnect the two hoses and plug them. Set the bolts and the reservoir aside to be reinstalled later.

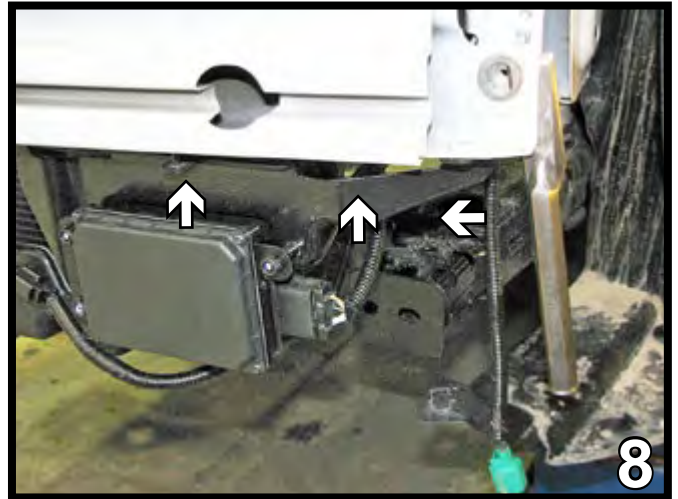

8. On driver's side only, using an 8MM socket, remove the two bolts from the bracket holding the speed control underneath the bumper. Set the bolts aside to be reinstalled later and move the speed control to the side out of the way.

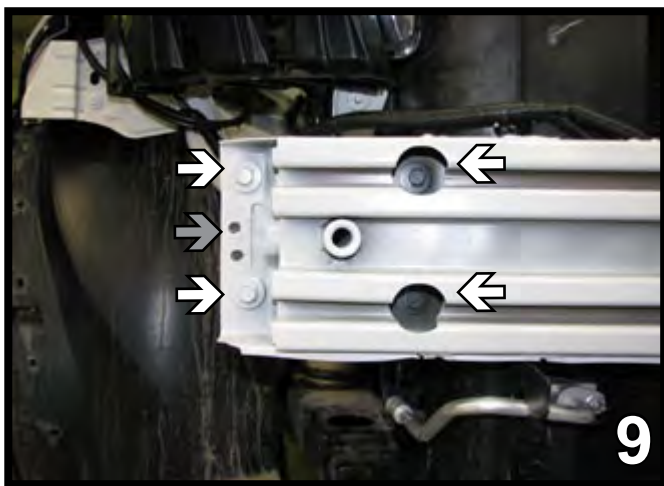

9. On the passenger side using a 13/32" drill bit, drill out the two spot welds on the metal bumper (gray arrow). Using a 13 MM socket, remove the four bolts (white arrows). Set the bolts aside to be reinstalled later.

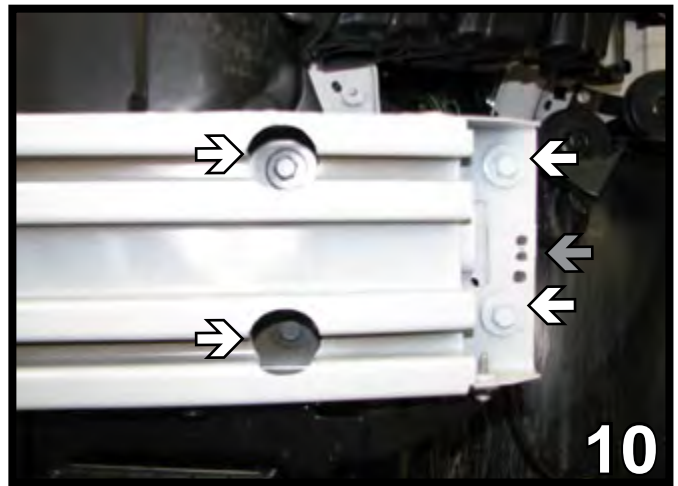

10. On the driver side using a 13/32" drill bit, drill out the three spot welds on the metal bumper (gray arrow). Using a 13MM socket, remove the four bolts (white arrows). Bolts and bumper will not be reinstalled.



BLUE OX®

Baseplate Installation Instructions

BX2632

2011-2013 Ford Explorer

With Adaptive Cruise Control & Eco Boost

Installation Instructions

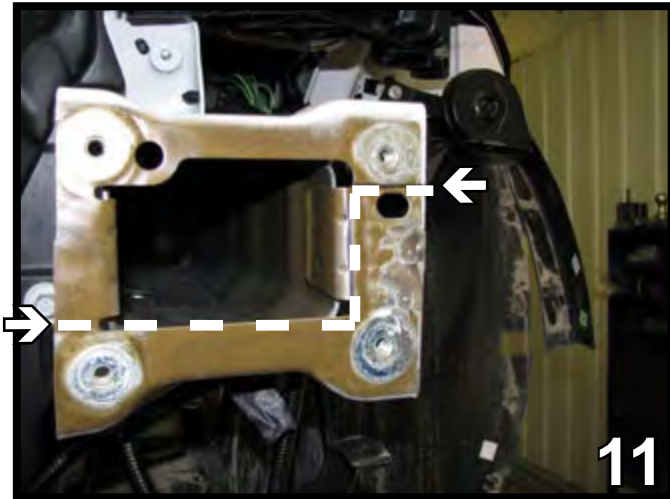

11. On the top outside of each bumper end, cut across at the bottom of the groove, straight down on the outside of the frame rail, across the bottom flush with the front of the frame and remove the whole piece. Do this on both sides.



12. On the passenger side, remove the top part of the plastic flap by cutting with a utility knife straight down above the hose. Notch out a little farther by cutting in as far as you can.

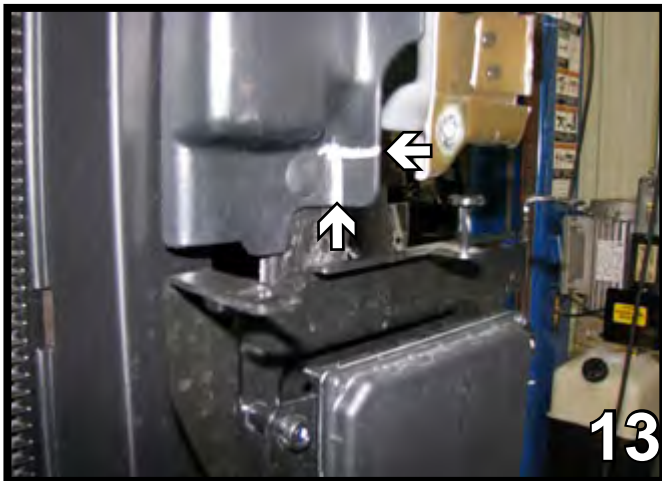

13. On the driver's side, cut a little square notch out of the corner of the plastic air dam with a utility knife.

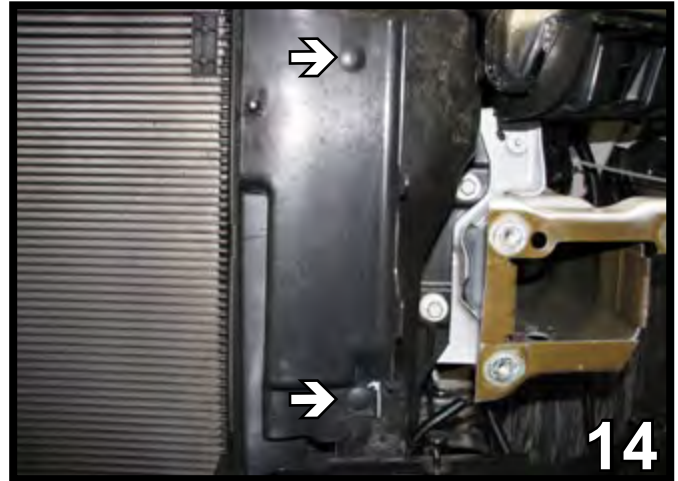

14. Remove the two push pins holding the plastic cover. Do this on both sides. Set the push pins and plastic aside to be reinstalled later.



BLUE OX®

Baseplate Installation Instructions

BX2632

2011-2013 Ford Explorer

With Adaptive Cruise Control & Eco Boost

Installation Instructions



15. Tip the baseplate up, lower the driver's side down, slide the baseplate in, lift up and clamp. Start the 3/4-10 bolt in the frame bottom existing hole. Do this on both sides.

NOTE: Some vehicles may require existing hole to be reamed or drilled, with a 25/32" drill bit.

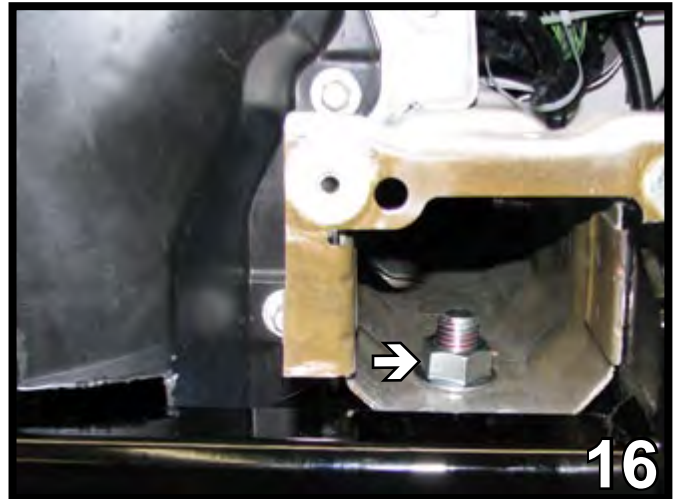

16. Install 3/4-10 x 1 3/4" bolts with 3/4" lock washers and 3/4-10 whiz nuts. Be sure to use loctite on all bolts. Do this on both sides.

When using power drills be aware of the dangers of torque and drill bit length.

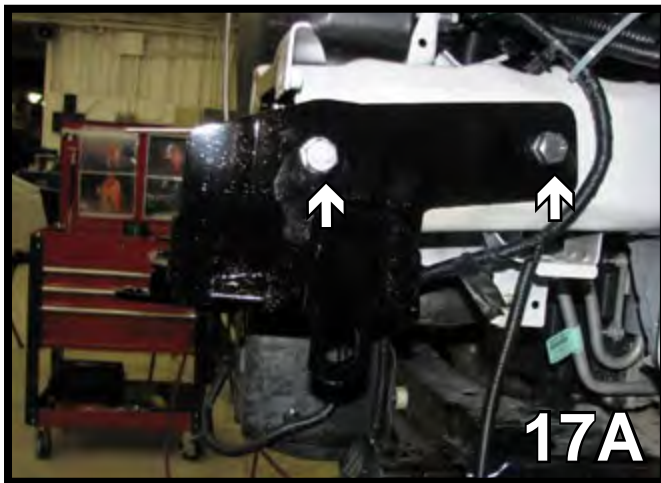

17A. Using the baseplate as a template, drill the two holes on the side with 17/32" drill bit. Insert two 1/2-13 x 1 1/2" bolts with 1/2" lock washers. Be sure to use loctite on all bolts.

17B. Tighten with two 1/2-13 nut plates aligned inside the frame rail. Do this on both sides.

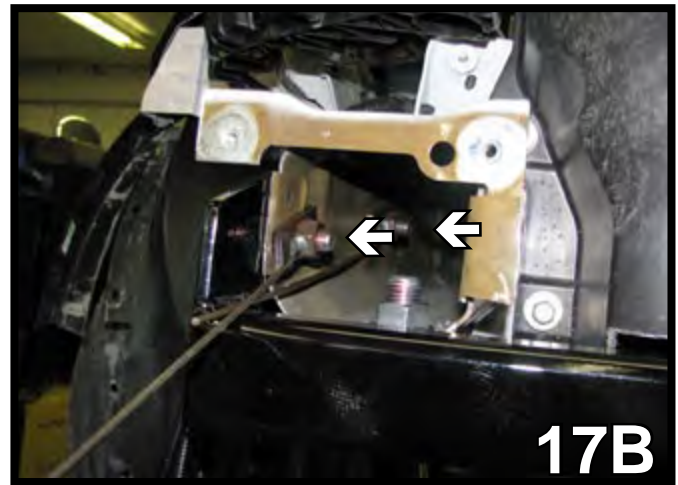

****BE SURE TO USE LOCTITE® RED ON ALL BOLTS BEFORE TIGHTENING. TIGHTEN ALL BOLTS ACCORDING TO THE TORQUE CHART ON THE FRONT PAGE OF THESE INSTRUCTIONS OR ON PAGE 3 OF THE BASEPLATE TOWING GENERAL INSTRUCTIONS.**



Baseplate Installation Instructions

BX2632
2011-2013 Ford Explorer
With Adaptive Cruise Control & Eco Boost
Installation Instructions



18. If the vehicle has adaptive cruise control, reattach it on the driver's side. Using a vise grip bend the pin downward out of the way.

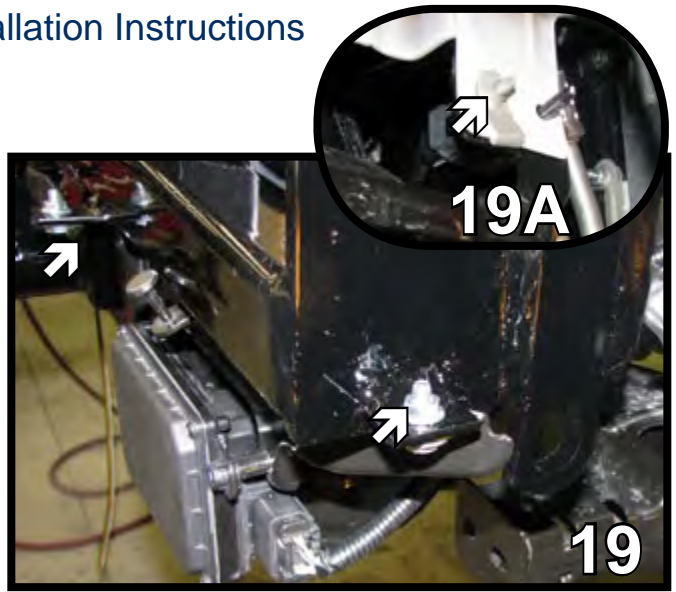

19. Slide the adaptive cruise control module to its original position, flush with the baseplate and in a perfectly vertical position. Reattach adaptive cruise control to the baseplate onto the tabs provided using 1/4-20 x 1" hex bolts and 1/4-20 whiz nuts (white arrows). If needed, 1/4" flat washers can be added to level the adaptive cruise control module. Using existing bolt attach final bolt behind baseplate to finish securing the module (19A).

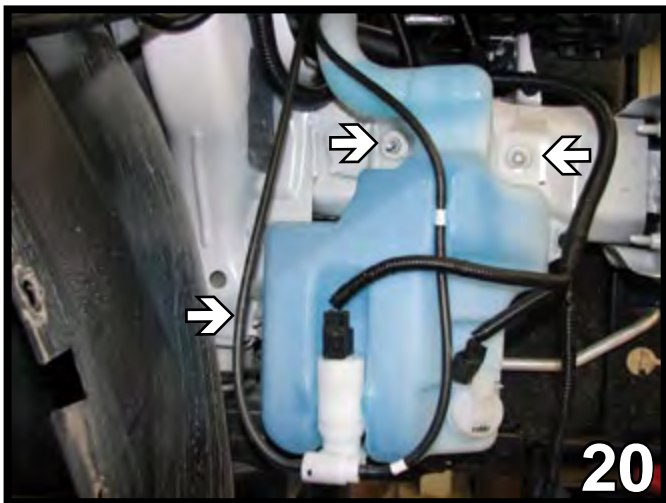

20. Reconnect the windshield washer reservoir, using all the existing hardware which was previously removed. Reconnect the two hoses and the electrical lines.

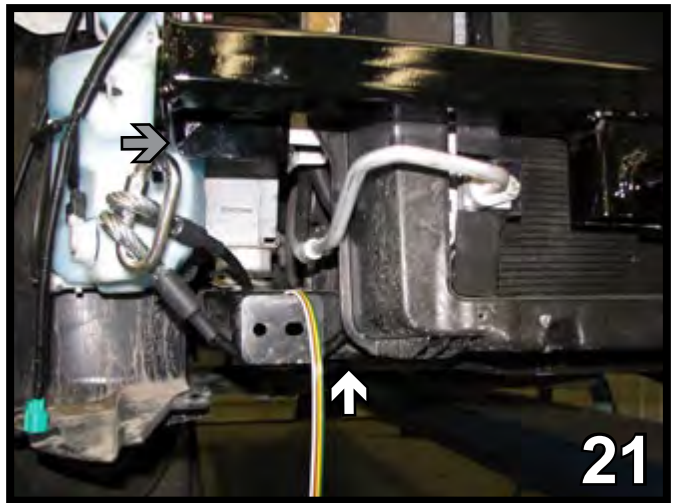

21. Attach the permanent baseplate safety cables to the provided convenience link on the baseplate (gray arrow). The photo above shows the recommended installation of the cables to frame of vehicle (white arrow). Additional options may interfere with suggested mounting; in this case secure the cables to a solid piece of the frame as described in the instructions included with the permanent baseplate safety cables. Be sure the safety cables do not rub against any hoses or moving parts. Do this to both sides of the vehicle.



Baseplate Installation Instructions

BX2632
2011-2013 Ford Explorer
With Adaptive Cruise Control & Eco Boost
Installation Instructions



- 22A. OPTIONAL: Attach the breakaway to the bracket with 1/4-20 x 3/4" hex bolt and 1/4-20 hex nut.
- 22B. Attach the breakaway bracket underneath the vehicle on the outside of the fascia.



- 23. On the backside of the fascia by the fog light, cut the white tab off. Do this on both ends of the fascia. Reinstall the fascia.

- 24. Install the electrical plug on the front of the fascia.

Reinstall the fascia, inserting all screws, pushpins, and bolts. The installation of the baseplate is now complete.

Install the tow bar and safety cables according to the instructions when demonstrating this to the customer. Be sure the safety cables do not rub against any hoses or moving parts.

Do NOT substitute other devices if the tow bar pin and clip are lost or misplaced.

Be sure that ALL electrical connections are plugged in properly and functioning BEFORE installing the fascia.



BLUE OX®

Baseplate Installation Instructions

BX2632

2011-2013 Ford Explorer

With Adaptive Cruise Control & Eco Boost

Installation Instructions

DEALER or INSTALLER:

Be certain the user receives the instruction sheets for their products.

CUSTOMER SERVICE COMMITMENT

Blue Ox is committed to providing you with exceptional customer care throughout your lifetime with our products. Our team is here to assist you with any questions you may have regarding the performance of your product. Simply call (402) 385-3051 and you can speak with our customer care team.

Additionally, please visit our website to see which rallies our Destination America team will be attending. For a nominal fee, our service technician will service your towing system to ensure it's in proper working condition. Also, as a commitment to our customers, should you visit our factory, you can stay at our full service Blue Ox campground at no charge along with enjoying a factory tour.

Again, thank you for being our customer and for the confidence you have shown in the performance of our products. It is because of customers like you we enjoy the success we have today.



Shown with removable tabs installed.



Shown without removable tabs installed.



© 2012 Blue Ox
One Mill Road, Industrial Park
Pender, Nebraska 68047
Phone: (402) 385-3051
Fax: (402) 385-3360
www.blueox.com