



# BX2642

## 2013-14 Ford Fusion SE (Includes Hybrid No Adaptive Cruise Control) Installation Instructions

Serial Number

**Attachment Tab Height: 14"**

**Attachment Tab Width: 25-1/2"**

**Please read BOTH these Installation Instructions and the General Instructions prior to installing or operating this equipment.**

- Blue Ox® towing products and accessories are intended to be installed by Blue Ox® Dealers who are familiar with our products and have the equipment and knowledge necessary to do "fit work". If needed, Blue Ox® Dealers can be found at [www.blueox.com](http://www.blueox.com) or by contacting our Customer Care Department at (402) 385-3051.
- Many Blue Ox® baseplates are designed to use existing holes and hardware to mount the baseplate to the towed vehicle. Even though bolts are there, do not assume they are adequate for baseplate mounting. Always use the hardware supplied in the hardware kit and existing hardware as specified in the installation instructions.

**Bolt Torque Specifications**  
Torque in Foot-Pounds for Metric Bolts

Bolt Size	Grade 8.8	Grade 10.9
6MM	6	8
8MM	16	22
10MM	31	40
12MM	54	70
14MM	89	117



**Bolt Torque Specifications**  
Torque in Foot-Pounds for Inch Bolts

Bolt Size	Grade 5	Grade 8
1/4"	10	14
5/16"	19	29
3/8"	33	47
7/16"	54	78
1/2"	78	119
5/8"	154	230

If the front of your vehicle looks different than this, please contact us at (402)385-3051.

**Reference your vehicle owner's manual for manufacturer's towing specifications.**

**! WARNING**

Failure to read and follow these instructions could result in separation of the towed vehicle from the tow bar, causing property damage, loss of towed vehicle, personal injury or death.

BX2642  
2013-14 Ford Fusion SE  
(Includes Hybrid No Adaptive Cruise Control)  
Installation Instructions

**Instruction Notes:** The fascia is removed and reinstalled for the baseplate installation. Some drilling and trimming is required.

Place all components that are removed on a flat, sturdy surface. All items will be reinstalled unless otherwise noted after the baseplate is installed.

The dimensional variations between otherwise identical vehicles can be considerable. While the baseplate was designed for easy installation, it may be necessary to tailor the baseplate slightly to compensate for vehicle manufacturer's tolerances.

## ***NOTICE***

- Handling of some cosmetic parts when installing this product may require the use of protective covers, rags, specialty tools, etc. to prevent damage.
- When using power drills be aware of the dangers of torque and drill bit length.
- When using a reciprocating saw be aware of objects behind the cutting surface.
- Use a good quality paint to spray cut edges of frame to prevent rusting.
- Be sure that **ALL** electrical connections are plugged in and accessories are functioning properly before reinstalling the fascia.
- **DO NOT** use the towed vehicle for storing luggage, equipment, etc. The baseplate is computer tested to your vehicle's GVWR, exceeding this weight will void the manufacturer's warranty.
- Be sure to use Loctite® Red on all bolts before tightening. Tighten all bolts according to the torque chart provided.
- Dealer or installer be certain the user receives these instruction sheet.
- If the baseplate is in an accident, it must be replaced. **DO NOT** use it again! An accident can cause unseen damage and using it again could result in more damage or serious injury. **DO NOT** use the baseplate if it is damaged or missing parts.

**BX2642**  
**2013-14 Ford Fusion SE**  
(Includes Hybrid No Adaptive Cruise Control)  
**Installation Instructions**

- Tools Required**
- Large Vise Grip
  - Flat Screwdriver
  - Utility Knife
  - Torque Wrench
  - Drill
  - Tape Measure
  - Loctite® RED
  - 3/8" Drill Bit
  - 1-1/4" Hole Saw
  - 7MM Socket
  - 10MM Socket
  - 13MM Socket
  - 9/16" Socket
  - 9/16" Wrench
  - T25 Torx

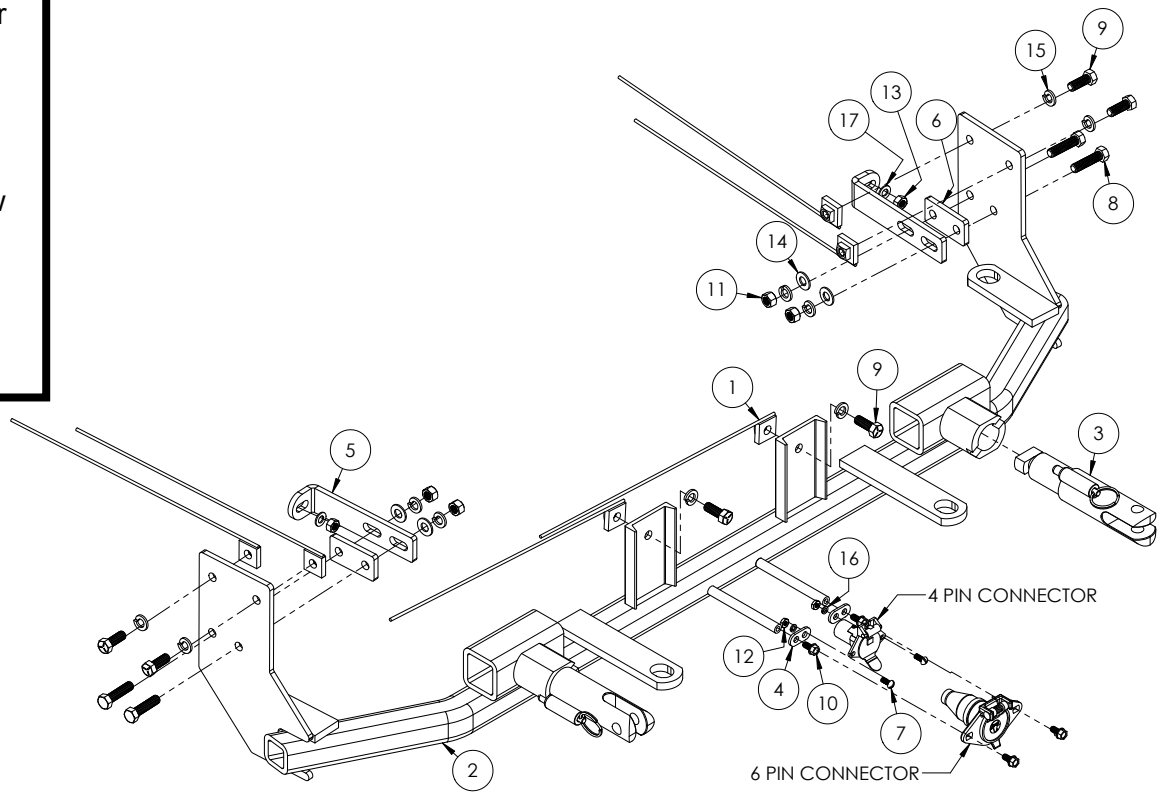

Item No.	Part No.	Description	Qty.
1.....	61-5208.....	3/8"-16 Nut Plate w/ 14" Wire.....	6
2.....	61-7161.....	BX2642 Baseplate.....	1
3.....	62-3468.....	Attachment Tab Assembly with Hole.....	2
4.....	101-5822.....	4 Way Connector Adapter.....	2
5.....	101-8137.....	BX2642 Side Bracket.....	2
6.....	101-8139.....	Spacer Plate.....	2
7.....	201-0192.....	#10-32 1/2" Round Slotted Head Screw.....	2
8.....	201-0440.....	3/8"-16 x 1-1/2" Hex Head Bolt, Grade 5, ZP.....	4
9.....	201-0443.....	3/8"-16 x 1" Hex Head Bolt, Grade 5, ZP.....	6
10.....	201-0553.....	1/4"-20 x 1/2" Hex Wshd Bolt Type F TCS, ZP.....	2
11.....	202-0003.....	3/8"-16 Hex Nut, ZP.....	4
12.....	202-0047.....	#10-32 Hex Nut.....	2
13.....	202-0118.....	8MM-1.25 Hex Nut, ZP.....	2
14.....	203-0003.....	3/8" Flat Washer, ZP.....	4
15.....	203-0010.....	3/8" Lock Washer, ZP.....	10
16.....	203-0054.....	#10 Lock Washer, ZP.....	2
17.....	203-0107.....	8MM Flat Washer, ZP.....	2
18.....	226-0046(not shown).....	Class III Safety Cables.....	2
19.....	229-0359(not shown).....	3/8" Quicklink, ZP.....	2
20.....	290-0437(not shown).....	Black Cap Plug Receiver.....	1

**Important:**

Use only genuine factory replacement parts on your baseplate. Do **NOT** substitute homemade or non-typical parts. If a bolt is lost or in need of replacement, for your safety and the preservation of your baseplate, be sure to use a replacement bolt of the same grade (In most cases it will be Grade 5, please reference the parts list above). Replacement parts may be ordered through your nearest Blue Ox® Dealer or Distributor. Failing to follow and/or altering these installation instructions in either installation or required equipment will void the manufacturer's warranty. Towing behind a non-motorized vehicle will void the warranty.

BX2642  
2013-14 Ford Fusion SE  
(Includes Hybrid No Adaptive Cruise Control)  
Installation Instructions

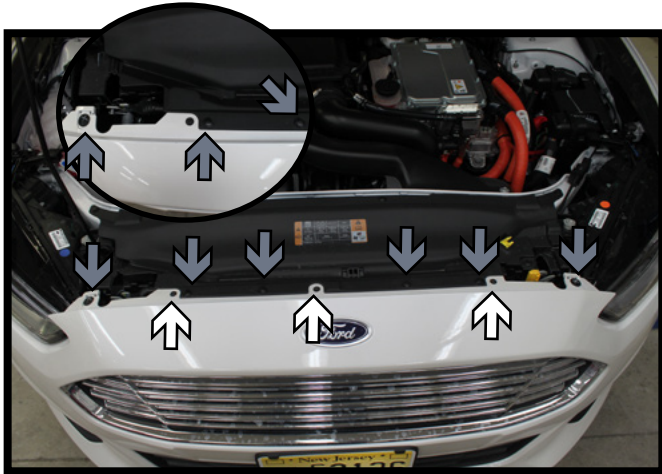

1. Using a T25 Torx, remove the three (3) screws from the top edge of the fascia (white). Remove the six (6) push pins from the top edge of the fascia.



2. Using a 10MM socket, remove the screw from the top edge of the wheel well (gray). Remove the three (3) push pins from the outer edge of the wheel well (white). Do this on both sides of the vehicle.

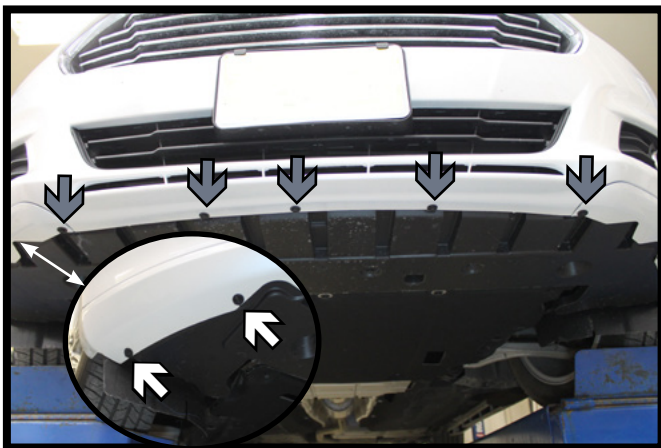

3. Using a 7MM Socket, remove the five (5) screws from the underside edge of the fascia (gray). Remove the push pins from the underside corners, there are two (2) on each side (white).



4. Pull the corners of the fascia out and away from the vehicle. Disconnect all electrical connections from the back side of the fascia. Remove the fascia from the vehicle and set aside.

BX2642  
2013-14 Ford Fusion SE  
(Includes Hybrid No Adaptive Cruise Control)  
Installation Instructions

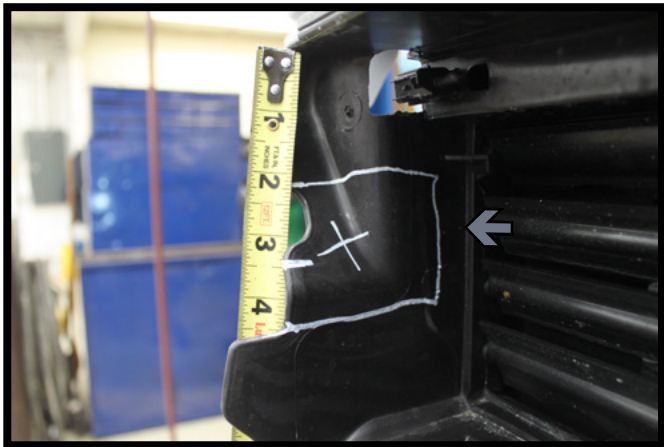

5. Trim the air baffle approximately as shown for baseplate clearance. Do this on both sides of the vehicle.

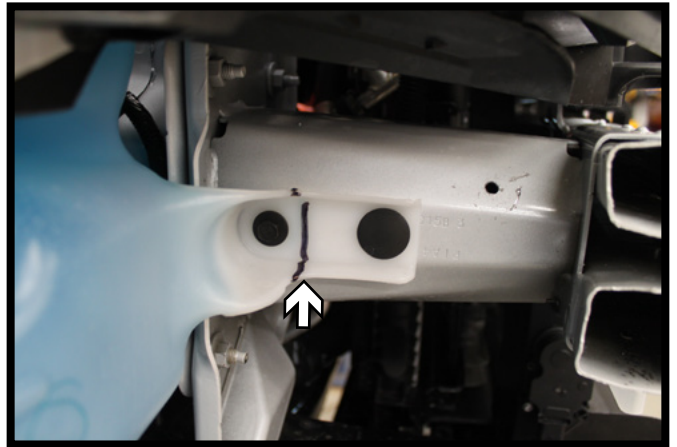

6. Using a utility knife, remove the outer flange of the washer fluid reservoir as shown.

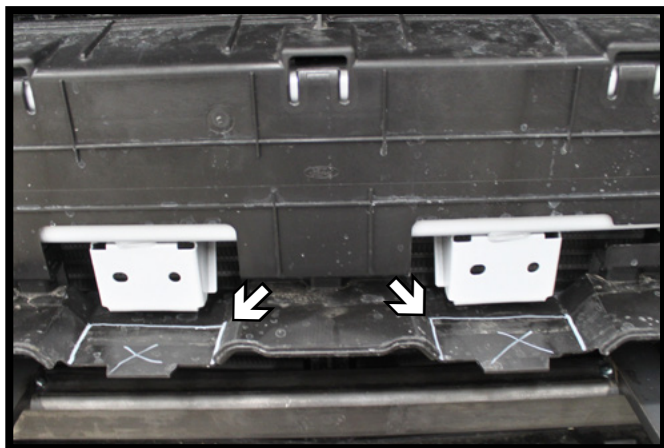

7. Using a utility knife, trim two (2) pockets in the plastic shrouding back flush to the metal brackets as shown.

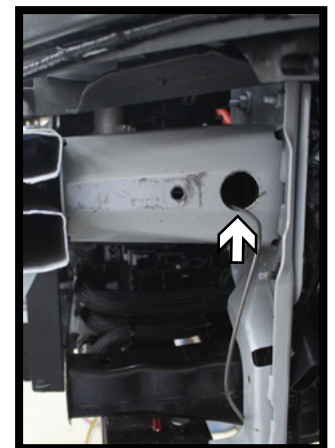
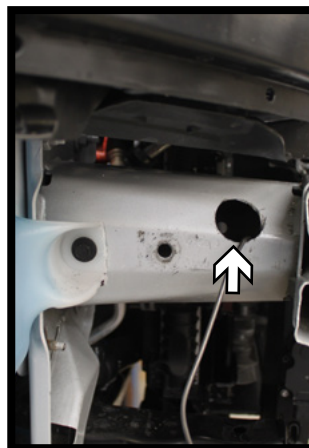

8. Using a 1-1/4" hole saw, drill an access hole on the passenger side (left) and driver side (right) as shown for nut plate access.

Note: On the passenger side keep the access hole as high up on the angled part of the frame to avoid the front hole of the baseplate.

BX2642  
2013-14 Ford Fusion SE  
(Includes Hybrid No Adaptive Cruise Control)  
Installation Instructions

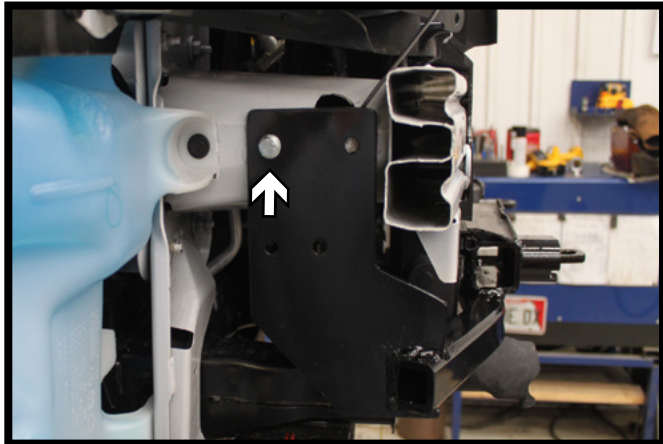

9. Using the existing hole, bolt the baseplate to the frame with a 3/8"-16 x 1" bolt, 3/8" lock washer and 3/8"-16 nut plate. Do this on both sides of the vehicle. Level and tighten down the baseplate.

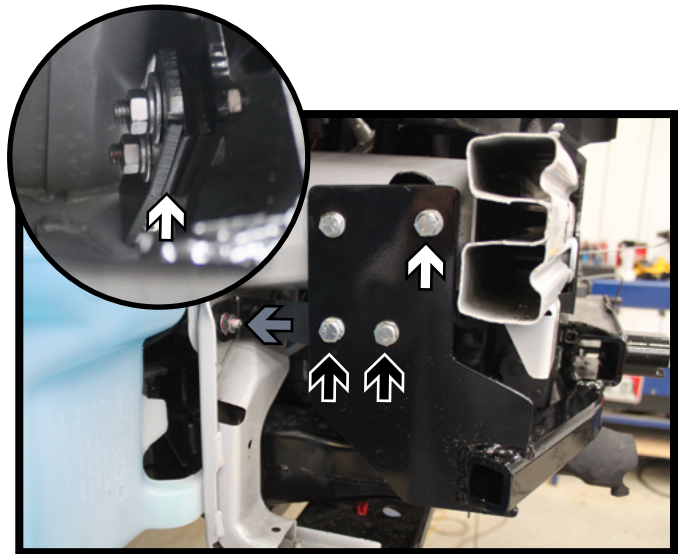

10. Using a 3/8" drill bit, drill the front top hole thru the frame. Install a 3/8"-16 x 1" bolt, 3/8" lock washer and 3/8"-16 nut plate (white). Using a 13MM socket, remove the existing frame nut and install the side bracket with a 8MM flat washer and 8MM nut (gray). Install 3/8"-16 x 1" bolts, 3/8" lock & flat washers and 3/8"-16 nuts into the lower holes (black) with the spacer plate in between the bracket and baseplate (inset). Do this on both sides of the vehicle.

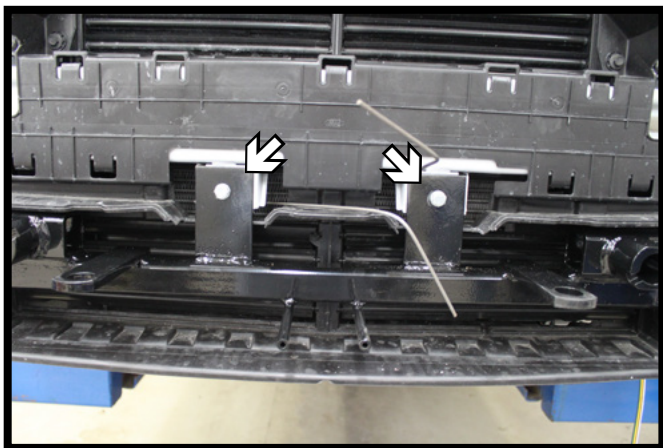

11. Using a 3/8" drill bit, drill the front holes thru the metal brackets. Install 3/8"-16 x 1" bolts, 3/8" lock washers and 3/8"-16 nut plates.

BX2642  
2013-14 Ford Fusion SE  
(Includes Hybrid No Adaptive Cruise Control)  
Installation Instructions

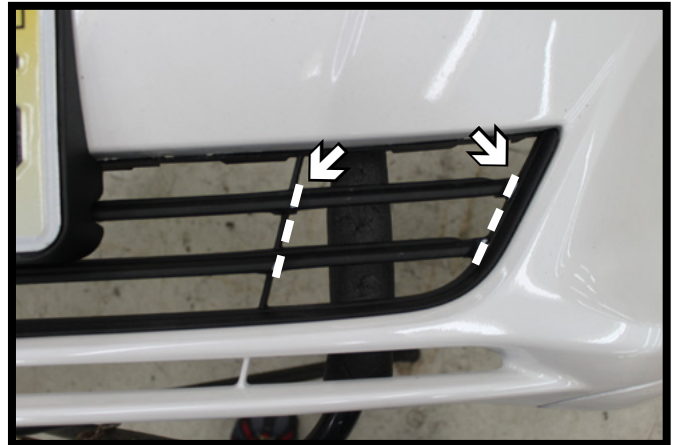
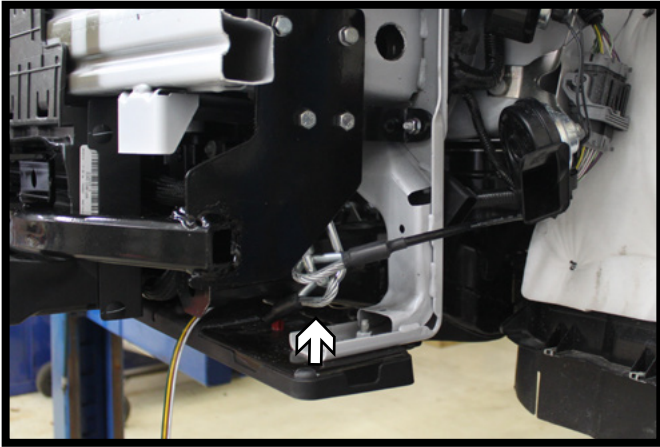

12. Attach the permanent baseplate safety cables to the provided convenience link on the baseplate. The photo beside shows the recommended installation of the cables to frame of vehicle. Additional options may interfere with suggested mounting; in this case, secure the cables to a solid piece of the frame as described in the instructions included with the permanent baseplate safety cables. Be sure the safety cables do not rub against any hoses or moving parts. Do this on **BOTH** sides of the vehicle.

13. Trim the two (2) horizontal bars from the lower grille opening as shown. Do this on both sides of the fascia. Reinstall the fascia.

### CUSTOMER SERVICE COMMITMENT

Blue Ox® is committed to providing you with exceptional customer care throughout your lifetime with our products. Our team is here to assist you with any questions you may have regarding the performance of your product. Simply call (402) 385-3051 and you can speak with our customer care team.

Additionally, please visit our website to see which rallies our Destination America team will be attending. For a nominal fee, our service technician will service your towing system to ensure it's in proper working condition. Also, as a commitment to our customers, should you visit our factory, you can stay at our full service Blue Ox® campground at no charge along with enjoying a factory tour.

Again, thank you for being our customer and for the confidence you have shown in the performance of our products. It is because of customers like you we enjoy the success we have today.

© 2012 Blue Ox  
One Mill Road, Industrial Park  
Pender, Nebraska 68047  
Phone: (402) 385-3051  
Fax: (402) 385-3360  
[www.blueox.com](http://www.blueox.com)