



Strong As An Ox™

BX3764 Installation Instructions 2005 Toyota Echo

Serial No.

The front fascia, metal bumper, bumper brackets and windshield washer reservoir are removed for baseplate installation. Drilling is required. Trimming of air dam is required. The bulb and socket tail light wiring kit (BX8869) is available for the vehicle. Attachment Tabs are 24 inches center to center and a height of 14 1/2 inches.



1. Remove the push pin from just below hood latch on top side of fascia.



2. Just forward of front tire is one metric bolt to remove with the 10MM socket, on both sides.



3. Remove the nine metric bolts from the lower edge of fascia with the 10MM socket (Driver's side shown).



4. Using the small flat screw driver, release the clip just outside headlight assembly on seam between the fender and front fascia, both sides. Pull corner of fascia down and to the side of vehicle, pull fascia forward and set aside.



5. Remove the two metric bolts from metal bumper using the 12MM socket, both sides. Pull metal bumper forward and set aside.



6. Remove the two metric bolts from bumper bracket, pull forward and set aside, on both sides.



Strong As An Ox™



7. Release the two clips on the back side of radiator support and pull air dam forward set aside, on both sides (Left photo above). Measure down 1 7/8" and mark the air dam from the edge just below where the metal bumper would set. Cut and remove the area below metal bumper back to first rib, down to 1 7/8" mark and cut a line forward to front edge. This will open area for baseplate.



8. Using the 10MM socket, remove the front metric bolt from windshield washer reservoir (Left Photo). Loosen the metric bolt on the back side of reservoir (Right Photo).



9. Slide the base plate onto the frame rail to align with the existing two holes on the driver's side. Install the two 10MM-1.25 x 35MM bolts, lock washers and flat washer, as shown in the drawing on the last page. Slide the end plate between frame and washer reservoir on passenger's side, align the lower back hole of the base plate with the existing hole for washer reservoir. Install 6MM-1 x 30MM hex bolt, lock washer and flat washer as shown in the drawing on the last page. **Be sure and use Loctite red on all bolts before tightening. Tighten all bolts according to torque chart in the General Instruction sheet.** Using the base plate as a template drill the upper back hole on the driver's side and the three holes on the driver's side, with the 13/32" drill bit. Drill a hole in the end of the frame rail with the 1 1/2" hole saw, on both sides.



10. Insert nut plates into opening on the end of frame rail to align with drilled holes on the passenger's side, tighten the three 3/8-16 hex bolts lock washers and flat washer, please refer to page 5. **Be sure and use Loctite on all bolts before tightening. Torque all bolts according to torque chart in General Instructions.**

11. Insert nut plates into opening on the end of frame rail to align with drilled holes on the driver's side, tighten the 3/8-16 hex bolt and lock washer, please refer to page 5. **Be sure and use Loctite on all bolts before tightening. Torque all bolts according to torque chart in General Instructions.**

12. Reinstall and tighten front 6MM-1 hex bolt into washer reservoir and tighten reservoir back bolt. Reinstall bumper brackets and metal bumper.

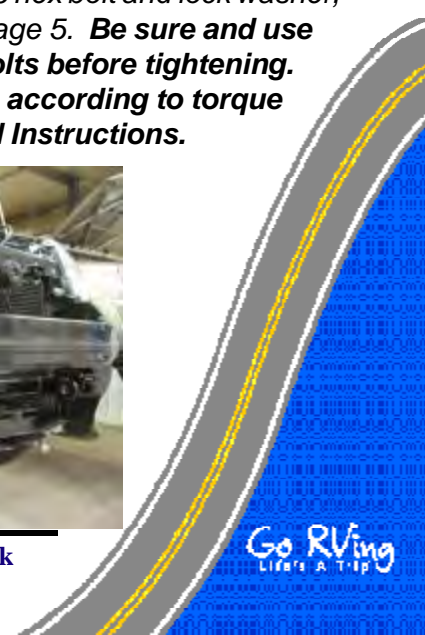



Strong As An Ox™



13. Align front fascia as close to it's original position as possible, cut opening in the lower grill to allow attachment receivers and convenience links to come through, both sides. Reinstall fascia. **Be sure that all eletrical components are plugged in properly.**

14. The dimensional variations between otherwise identical cars can be considerable. While the base plate was designed for easy installation, it may be necessary to tailor the baseplate slightly to compensate for auto manufacturers' tolerances. These minor adjustments may include filing a hole slightly, bending electrical rods, adding shims and/ or bending endplates.

15. Install the tow bar and safety cables according to the instructions included in their packages.

16. Do **not** substitute other devices if the tow bar pin and clip are lost.

17. **DEALER OR INSTALLER: BE CERTAIN THE USER RECEIVES THE INSTRUCTION SHEET.**



Location for the Bx8869 on driver's side tail light assembly.

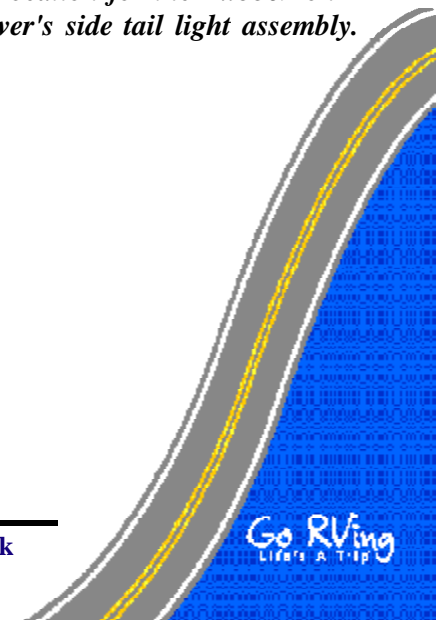



Strong As An Ox™

Tools Required

10MM Socket
9/16" Socket
Utility Knife

12MM Socket
Loctite Red
Small Flat Screw Driver

14MM Socket
Vise Grip

Parts List

Ref. No.	Qty.	Part No.	Description
1	1	61-6140	Weldment, Base Plate, BX3764
2	3	61-5208	Weldment, 3/8-16 Nut Plate, w/ 14" Wire
3	3	201-0440	3/8-16 x 1 1/2 Hex Bolt, Grd. 5, ZP
4	3	203-0010	3/8" Lock Washer, ZP
5	2	203-0003	3/8" Flat Washer, ZP
6	2	201-0423	10MM-1.25 X 35MM Hex Bolt, Grd. 8.8, ZP
7	2	203-0104	10MM Lock Washer, ZP
8	1	201-0655	6MM-1.00 X 30MM Hex Bolt, Grd. 8.8, ZP
9	1	203-0008	1/4" Lock Washer, ZP
10	1	203-0001	1/4" Flat Washer, ZP
11	2	201-0553	1/4-20 x 1/2 Hx. Wshd, Type F Screw
12	2	201-0192	#10-32 x 1/2 Slot, Rd. Hd. Screw
13	2	203-0054	#10 Lock Washer
14	2	202-0047	#10-32 Hex Nut
15	2	101-5822	Adapter, 4 Way Connector
16	2	62-3468	Attachment, Assembly, SF/ SB (R)
	2	290-0437	Receiver Cap, Plug, Blk. (Not Shown)
	2	226-0046	Baseplate Safety Cable, 36" CL III (Not Shown)
	2	229-0359	Quicklink, 3/8, ZP (Not Shown)

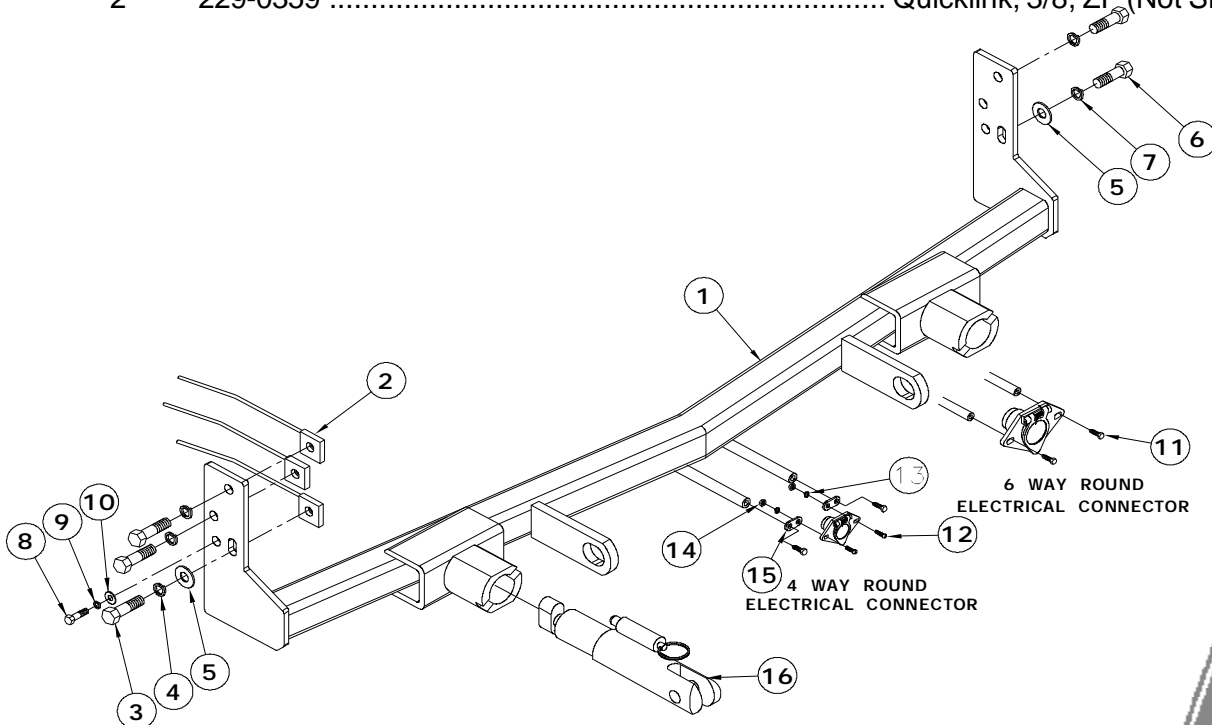

IMPORTANT: Use only genuine factory replacement parts on your Base Plate. Do not substitute homemade or non-typical parts. If a bolt is lost or in need of replacement, for your safety and the preservation of your Base Plate, be sure to use a replacement bolt of the same grade (Usually Grade 5, refer to parts list). Repair parts may be ordered through your nearest **Blue Ox** dealer or distributor.