

11704**89-92 FORD PROBE EXCEPT GT**

12/10/2012

GROSS LOAD CAPACITY WHEN USED AS A WEIGHT CARRYING HITCH: 2,000 LBS. TRAILER WEIGHT & 200 LBS. TONGUE WEIGHT.

*****DO NOT EXCEED VEHICLE MANUFACTURER'S RECOMMENDED TOWING CAPACITY.*****

WARNING: ALL NON-TRAILER LOADS APPLIED TO THIS PRODUCT MUST BE SUPPORTED BY 18050 STABILIZING STRAPS.

**** FAILURE TO PROPERLY SUPPORT NON-TRAILER LOADS WILL VOID PRODUCT WARRANTY****

HAVING INSTALLATION QUESTIONS? CALL TECHNICAL SUPPORT AT 1-877-287-8634

Parts List

ITEM	QTY	PART NUMBER	DESCRIPTION
1	4	7/16-14	HEX FLANGE NUT
2	2	7/16-14 x 1 1/4	HEX BOLT
3	2	7/16-14 TAB NUT	HANDLE NUT
4	2	7/16 LOCK WASHER	HELICAL LOCK WASHER
5	2	7/16 WASHER	WASHER
6	2	7/16-14 x 1.63 x 2.50 C-C	SQ. U-BOLT

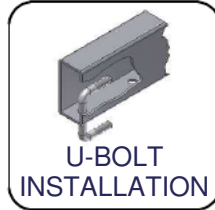
**RUBBER ISOLATOR
REMOVAL DIAGRAM**

This technique can be used if and Exhaust Hanger Removal Pliers is not available.

Using a 5/8" open end wrench, slide the wrench up to the rubber isolator, cradling the hanger rod as shown. Next place the flat edge of a pry bar between the wrench and the hanger stop or hanger rod. Then simply rotate the pry bar toward the wrench to remove the rubber isolator.

Note: Using a spray lubricant or soapy water on the hanger rod and the rubber isolator helps removal.

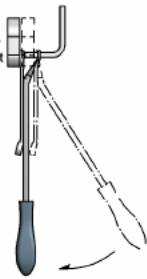

FRONT
↕
REAR

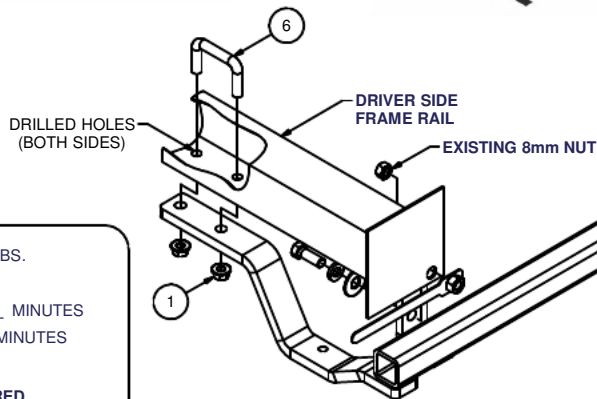
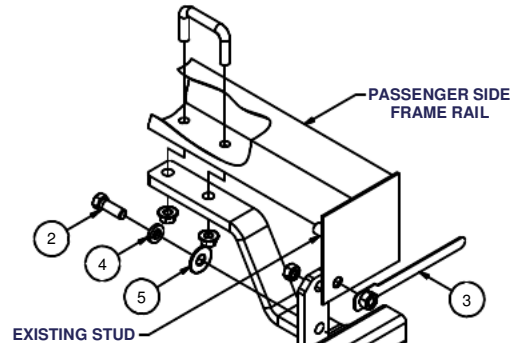

DESIGNED FOR USE WITH
BALLMOUNT #55001 / 45501

HITCH WEIGHT: 26 LBS.

INSTALL TIME

PROFESSIONAL: 20 MINUTES

NOVICE (DIY): 40 MINUTES

INSTALL NOTES:

- DRILLING REQUIRED
- LOWER EXHAUST

INSTALLATION STEPS

1. Under the vehicle, remove (1) 8mm nut from stud on inboard side of each frame rail at rear. Temporarily lower exhaust by removing rear most hangers.
2. Notch vertical section of plastic fascia tabs as shown above to clear cross tube.
3. Position the hitch on vehicle as shown above. Upper holes in brackets pass over 8mm studs. Reinstall 8mm nuts and secure the hitch in position on the vehicle.
4. Drill vehicle frame rails 1/2" diameter through hitch arms (1) places per rail (1 hole per side may exist). Drill car's rear panel 1/2" diameter through lower holes in hitch bracket (1) hole per side.
5. Lower hitch and insert U-bolts by placing (1) end into the hole and sliding it in until the inserted end comes out of the adjacent hole. Raise hitch over U-bolts carefully and fasten as shown above. Note: Do not use impact wrench on U-bolts.
6. Torque all 8mm hardware to 23 lb.-ft. and all 7/16" hardware to 70 lb.-ft.
7. Reinstall exhaust.

**PERIODICALLY CHECK THIS RECEIVER HITCH TO ENSURE THAT ALL FASTENERS
ARE TIGHT AND THAT ALL STRUCTURAL COMPONENTS ARE SOUND.**

Curt Manufacturing Inc., warrants this product to be free of defects in material and/or workmanship at the time of retail purchase by the original purchaser. If the product is found to be defective, Curt Manufacturing Inc., may repair or replace the product, at their option, when the product is returned, prepaid, with proof of purchase. Alteration to, misuse of, or improper installation of this product voids the warranty. Curt Manufacturing Inc.'s liability is limited to repair or replacement of products found to be defective, and specifically excludes liability for incidental or consequential loss or damage.