

**12207****74-93 VOLVO 140, 160, 240, 260 SERIES**

11/19/2012

GROSS LOAD CAPACITY WHEN USED AS A WEIGHT CARRYING HITCH: 3500 LBS. TRAILER WEIGHT &amp; 300 LBS. TONGUE WEIGHT.

**\*\*\*DO NOT EXCEED VEHICLE MANUFACTURER'S RECOMMENDED TOWING CAPACITY.\*\*\*****WARNING: ALL NON-TRAILER LOADS APPLIED TO THIS PRODUCT MUST BE SUPPORTED BY AUXILIARY STABILIZING STRAPS.****\*\* FAILURE TO PROPERLY SUPPORT NON-TRAILER LOADS WILL VOID PRODUCT WARRANTY\*\***

HAVING INSTALLATION QUESTIONS? CALL TECHNICAL SUPPORT AT 1-800-798-0813

Parts List			
ITEM	QTY	PART NUMBER	DESCRIPTION
1	2	M14 - 2 x 120 HEX	HEX BOLT
2	2	FW12	FW, 12, ZP
3	2	5_8 LOCK WASHER	HELICAL LOCK WASHER
4	2	M14 - 2 HEX NUT	HEX NUT
5	4	M10 - 1.5 x 30 HEX	HEX BOLT
6	4	3/8"	WASHER
7	4	7/16 LOCK WASHER	HELICAL LOCK WASHER
8	2	CM-SP133	.84 OD DOM x 11 GA SPACER TUBE

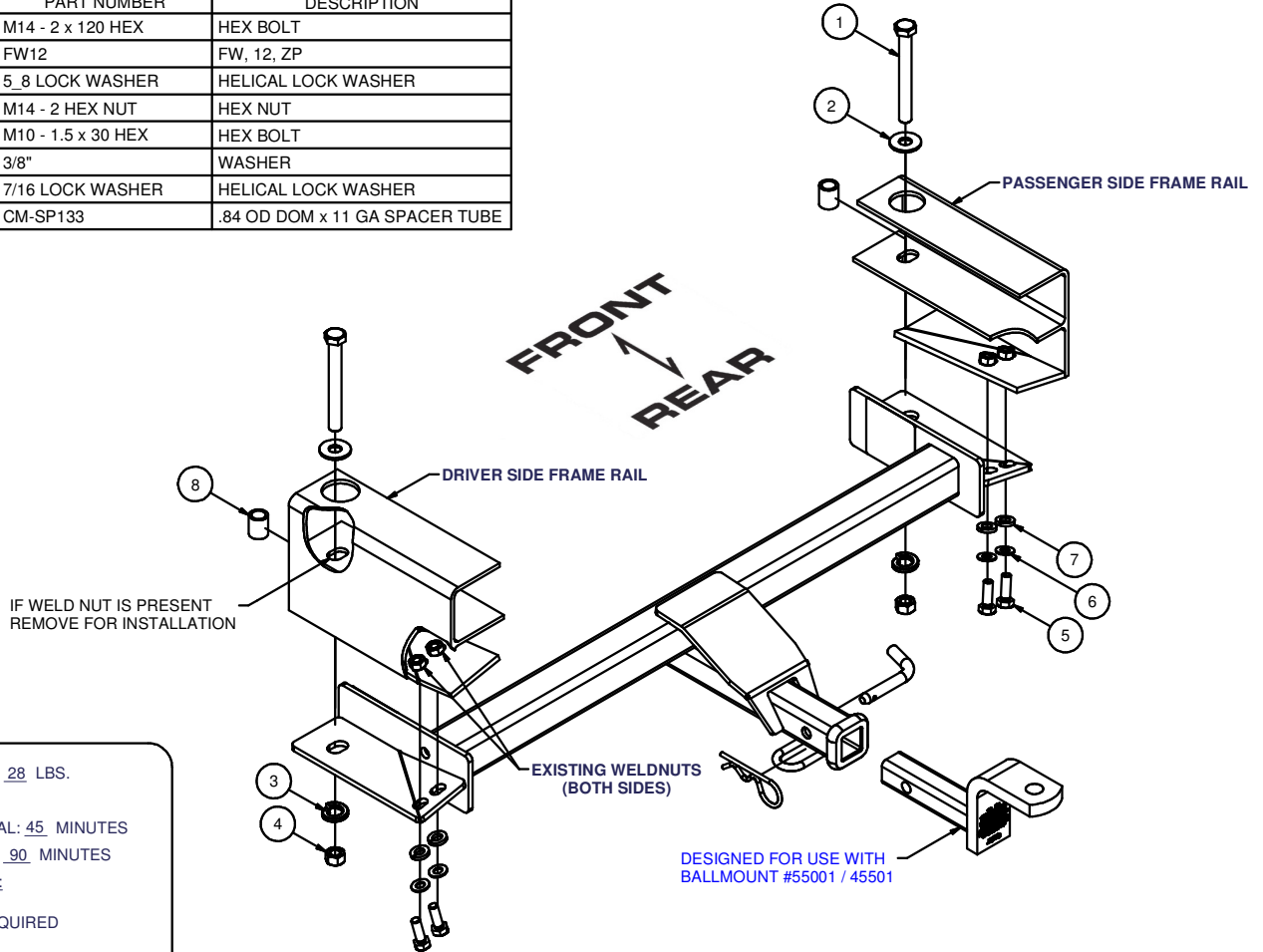
HITCH WEIGHT: 28 LBS.INSTALL TIMEPROFESSIONAL: 45 MINUTESNOVICE (DIY): 90 MINUTESINSTALL NOTES:

-DRILLING REQUIRED

**INSTALLATION STEPS**

- The following items will be permanently removed from the car:
  - A metal panel hiding the muffler on certain models (1987 and later, plastic rear section only).
  - A tow hook on one side. The muffler hanger is then reinstalled.  
All parts permanently removed from the car should be returned to the vehicles owner for reinstallation should the hitch ever be removed.
- Remove one screw per side holding the muffler heat shield to the frame rails.
- Inside the car's trunk, locate and remove two (one per side) 14 mm screws retaining the bumper brackets to the frame rails. Replace using 14 mm screws supplied with the hitch as part of the fasteners. Tighten these screws to secure bumper brackets.
- Under the car, locate the 14 mm screws just installed and place spacer tubes provided over these screws at the access holes in the frame rails as shown, and mount using the balance of the fasteners.
- Torque all 10mm fasteners to 48 lb-ft, and all 14mm fasteners to 126 lb-ft.

**PERIODICALLY CHECK THIS RECEIVER HITCH TO ENSURE THAT ALL FASTENERS ARE TIGHT AND THAT ALL STRUCTURAL COMPONENTS ARE SOUND.**

Curt Manufacturing Inc., warrants this product to be free of defects in material and/or workmanship at the time of retail purchase by the original purchaser. If the product is found to be defective, Curt Manufacturing Inc., may repair or replace the product, at their option, when the product is returned, prepaid, with proof of purchase. Alteration to, misuse of, or improper installation of this product voids the warranty. Curt Manufacturing Inc.'s liability is limited to repair or replacement of products found to be defective, and specifically excludes liability for incidental or consequential loss or damage.