

12217

93-03 VOLKSWAGEN EUROVAN

11/12/2020

GROSS LOAD CAPACITY WHEN USED AS A WEIGHT CARRYING HITCH: 3,500 LBS. TRAILER WEIGHT & 300 LBS. TONGUE WEIGHT.
*****DO NOT EXCEED VEHICLE MANUFACTURER'S RECOMMENDED TOWING CAPACITY.*****

Parts List			
ITEM	QTY	PART NUMBER	DESCRIPTION
1	1	20-00174	NUT, HANDLE, 1/2-13 UNC, GRD8, CZ
2	6	10-10425	HHCS, 7/16-14 UNC, 1-1/4, GRD8, YZ
3	6	20-00103	NUT, SER-FLANGE, 7/16-14 UNC, GRD8, YZ
4	4	10-10411	HHCS, M12x1.5, 35, CL10.9, YZ
5	6	30-00149	WASHER, S-CON, 1/2, YZ
6	1	20-00062	NUT, SER-FLANGE, 1/2-13 UNC, GRD8, YZ
7	2	10-10470	HHCS, 1/2-13 UNC, 1-1/4, GRD8, YZ

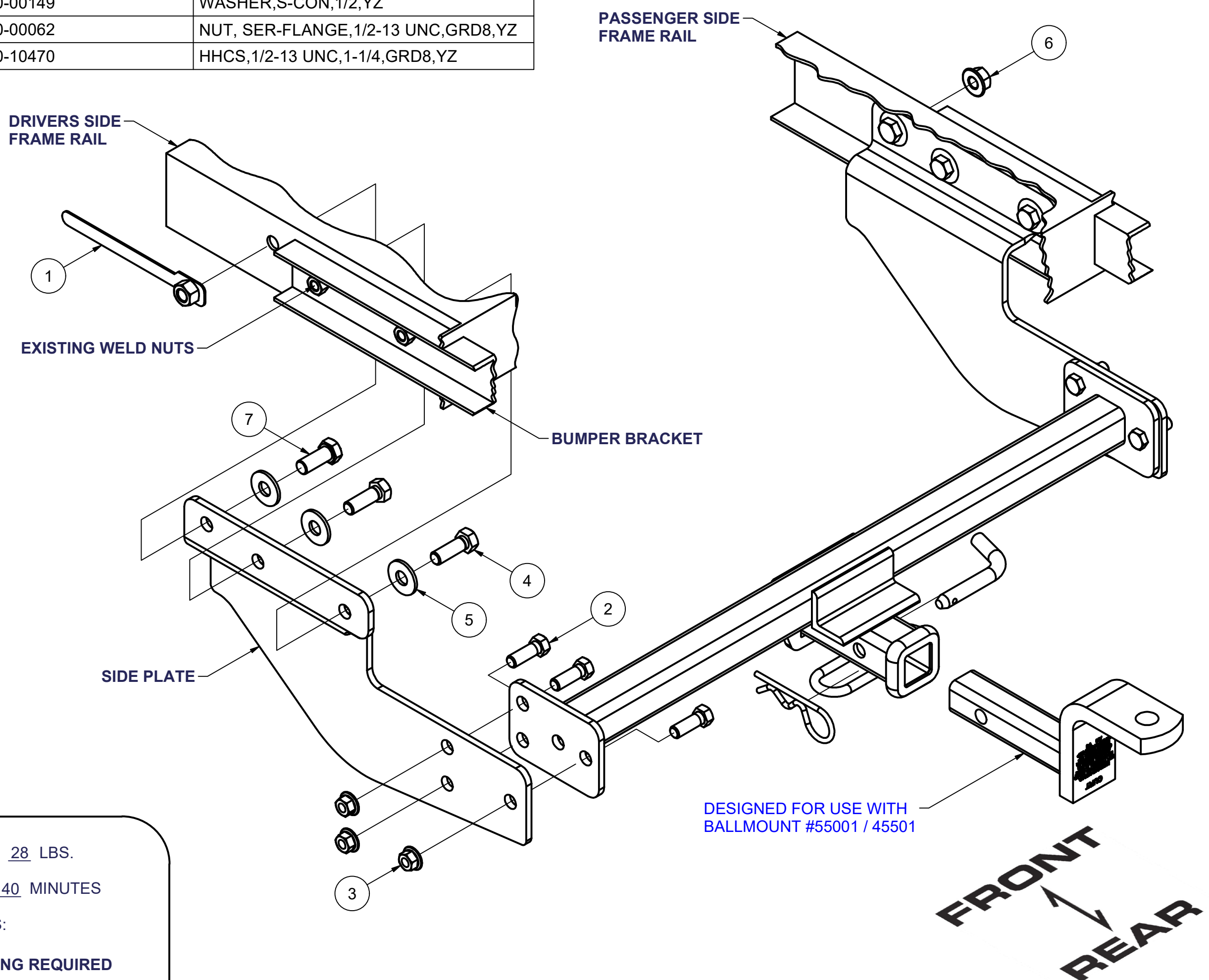
HITCH WEIGHT: 28 LBS.INSTALL TIME: 40 MINUTES

INSTALL NOTES:

NO DRILLING REQUIRED

INSTALLATION STEPS

- 1) Remove the two rear most frame bolts that attach the bumper brackets to the frame rails. Mount side plates to inner surface of frame rails aligning rear most holes with existing weldnuts in bumper bracket. Loosely install fasteners as shown.
 (Note: It may be necessary to remove plastic clips holding wire bundle inside passenger side frame.)
- 2) Mount receiver assembly between frame plates and install fasteners as shown.
- 3) Torque 1/2" fasteners to 110 lb.-ft., M12 fasteners to 83 lb.-ft., and 7/16" fasteners to 59 lb.-ft.

PERIODICALLY CHECK THIS RECEIVER HITCH TO ENSURE THAT ALL FASTENERS ARE TIGHT AND THAT ALL STRUCTURAL COMPONENTS ARE SOUND.

Curt Manufacturing Inc., warrants this product to be free of defects in material and/or workmanship at the time of retail purchase by the original purchaser. If the product is found to be defective, Curt Manufacturing Inc., may repair or replace the product, at their option, when the product is returned, prepaid, with proof of purchase. Alteration to, misuse of, or improper installation of this product voids the warranty. Curt Manufacturing Inc.'s liability is limited to repair or replacement of products found to be defective, and specifically excludes liability for incidental or consequential loss or damage.