

13326 / 3814AT / RRR13326

2002 DODGE RAM 1500 (BUILT BEFORE 11/02)

8/13/2020

GROSS LOAD CAPACITY WHEN USED AS A WEIGHT CARRYING HITCH: 5,000 LBS. TRAILER WEIGHT & 500 LBS. TONGUE WEIGHT.
 GROSS LOAD CAPACITY WHEN USED AS A WEIGHT DISTRIBUTION HITCH: 10,000 LBS. TRAILER WEIGHT & 1,000 LBS. TONGUE WEIGHT

DO NOT EXCEED VEHICLE MANUFACTURER'S RECOMMENDED TOWING CAPACITY.

Parts List			
ITEM	QTY	PART NUMBER	DESCRIPTION
1	1	1_2 x 30 FISHWIRE	1/2" x 30" FISHWIRE
2	2	CM-SP6	.250 x 1.00 x 3.00" SQUARE HOLE SPACER
3	2	10-10288	BOLT,CAR,1/2-13 UNC,2,GRD8,YZ
4	2	20-00062	NUT, SER-FLANGE,1/2-13 UNC,GRD8,YZ
5	2	10-10517	FHSCS,5/8-11 UNC,2,N/A,YZ
6	2	20-00105	NUT,SER-FLANGE,5/8-11 UNC,GRD8,YZ
7	1	CM-13326-BP	.625 x 2.00" BACKING PLATE

FISHWIRE TECHNIQUE

INSERT COILED END OF FISHWIRE TOOL THROUGH HITCH MOUNTING HOLE IN VEHICLE FRAME RAIL AND OUT THE ACCESS HOLE. PASS COILED END OF FISHWIRE THROUGH SPACER AND THREAD BOLT INTO COIL. KINK WIRE TO KEEP SPACER SEPERATE FROM BOLT AS SHOWN. PULL FISHWIRE, SPACER, AND BOLT THROUGH FRAME AND OUT MOUNTING HOLE. USE FISHWIRE TO GUIDE HITCH DURING MOUNTING AND PREVENT LOSS OF BOLT / SPACER INSIDE FRAME RAIL.

NOTE: SOME VEHICLES MAY FISHWIRE THROUGH END OF FRAME**

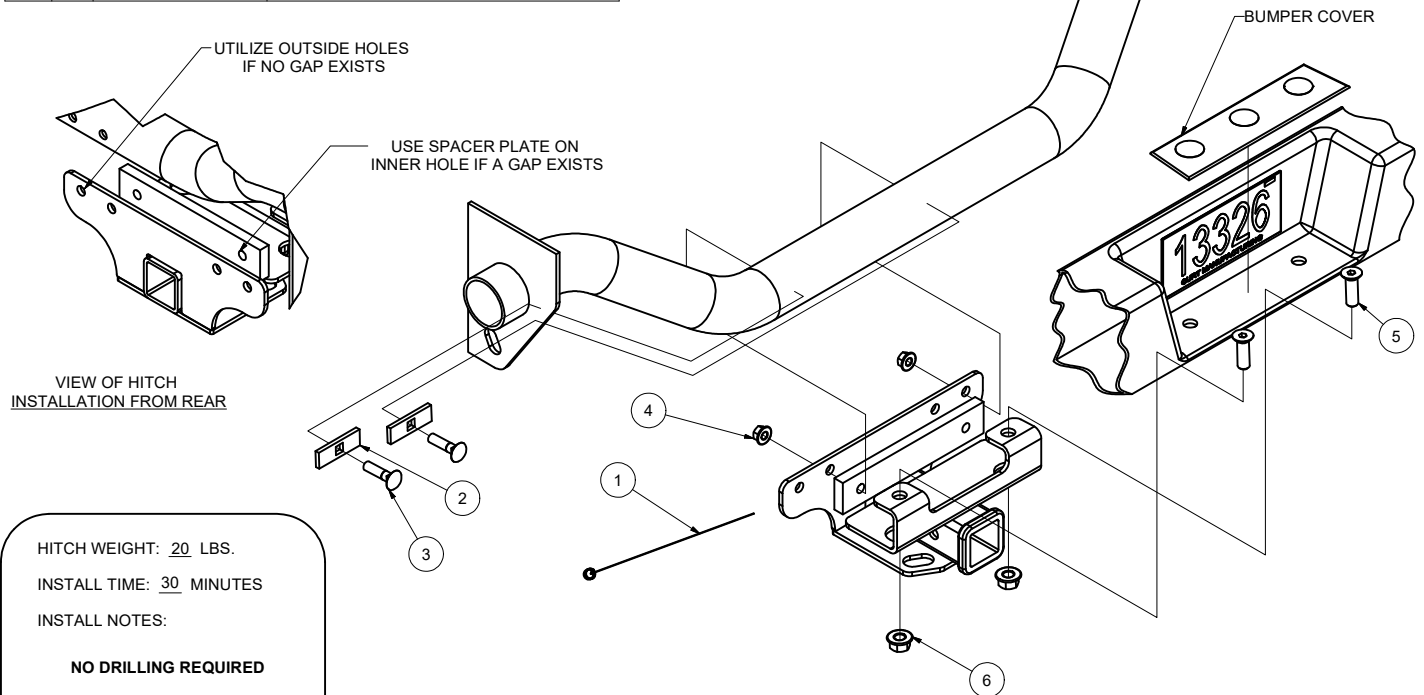
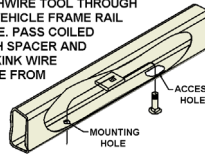

HITCH WEIGHT: 20 LBS.

INSTALL TIME: 30 MINUTES

INSTALL NOTES:

NO DRILLING REQUIRED

INSTALLATION STEPS

- 1) Locate the four plastic locking studs under the bumper which hold the bumper cover to the top of the steel bumper. With a pair of pliers, carefully squeeze these studs together and push them up through the bumper. Use care when removing these studs as to not damage the locking tabs on the studs. From the top, carefully pull the bumper cover up to gain access to the top of the steel bumper. Do not deform the bumper cover when removing it. Underneath the bumper cover there will be two 3/4" diameter holes on either side of the bumper cavity. These holes will be utilized for hitch attachment.
- 2) Place a 5/8" flat head bolt down through each of the outer 3/4" holes in the bumper as shown,
- 3) Carefully position the hitch against the bottom surface of the bumper so that the previously installed bolts drop through the holes in the hitch. Loosely secure using fasteners as shown.
- 4) Using the included fishwire, insert a 1/2" carriage bolt and rectangular backing plate into the end of the round inner bumper beam. Pull the bolts out through the holes in the bumper beam as shown.
NOTE: Check to see if there is a gap between the bumper beam and the hitch mounting plate. If there is a gap, place the spacer plate between the bumper beam and the hitch mounting plate before installation of the attachment fasteners. If there is not a gap, the spacer plate is not used.
- 5) Torque all 5/8" fasteners to 210 lb-ft, and all 1/2" fasteners to 110 lb-ft.

PERIODICALLY CHECK THIS RECEIVER HITCH TO ENSURE THAT ALL FASTENERS ARE TIGHT AND THAT ALL STRUCTURAL COMPONENTS ARE SOUND.

Curt Manufacturing Inc., warrants this product to be free of defects in material and/or workmanship at the time of retail purchase by the original purchaser. If the product is found to be defective, Curt Manufacturing Inc., may repair or replace the product, at their option, when the product is returned, prepaid, with proof of purchase. Alteration to, misuse of, or improper installation of this product voids the warranty. Curt Manufacturing Inc.'s liability is limited to repair or replacement of products found to be defective, and specifically excludes liability for incidental or consequential loss or damage.