

INSTALLATION MANUAL

48334

Level of Difficulty

Easy

Installation difficulty levels are based on time and effort involved and may vary depending on the installer level of expertise, condition of the vehicle and proper tools and equipment.

Parts List

Item	Qty	Description
1	4	Hex nut, 1/2"
2	4	Lock washer, 1/2"
3	4	Socket head cap screws, 1/2"-13

Tools Required

Ratchet	Wrench, 3/4"
Hex socket, 3/8"	--

Torque Specifications

1/2" Socket head cap screw	100 ft-lbs.
Use above torque setting unless otherwise noted	

Product Registration and Warranty

CURT stands behind our products with industry-leading warranties. To get copies of the product warranties, register your purchase or provide feedback, visit: warranty.curtgroup.com/surveys

⚠ WARNING

Vehicle performance (braking, handling, acceleration, turning radius) can be drastically affected by towing a trailer. Allow additional time and space for stopping, changing lanes, passing and turning.

Do not tow more than one trailer at a time.

Severe bumps can damage your towing system. Avoid or drive slowly over rough terrain.

Do not damage the latch when using a pintle mount.

Be particularly careful with a drawbar when coupling and uncoupling.

Never exceed the vehicle manufacturer's recommended towing capacity.

Product Photo



NOTICE

Visit www.curtmfg.com for a full-color copy of this instruction manual, as well as helpful videos, guides and much more!

Before you begin installation, read all instructions thoroughly.

Proper tools will improve the quality of installation and reduce the time required.

Periodic inspection of your product should be performed to ensure all hardware and / or components remain secure.

To help prevent damage to the product or vehicle, refer to the specified torque specifications when securing hardware during the installation process.

Mounting Instructions

Mounting structure must be capable of supporting the rated pintle hook capacity in accordance with SAE J847.

Only use CURT supplied mounting hardware and refer to the torque specifications in this manual.

RECOMMENDED MOUNTING CONFIGURATIONS

Figure 1

When mounting a pintle to a flat plate or bumper, insert the 1/2" socket head cap screws (#3) through the pintle and mounting plate as shown. Secure with 1/2" lock washers (#2) and hex nuts (#1) on the back side of the mounting plate.

Torque all four fasteners to 100 ft-lbs.

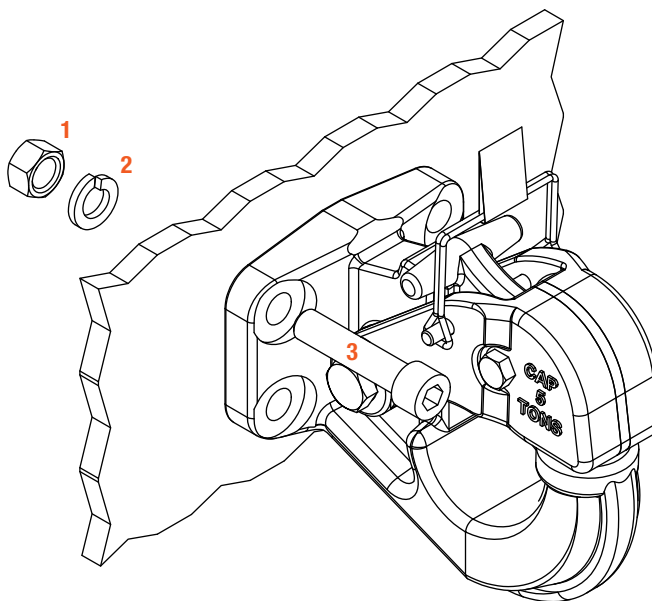

Figure 2

When installing a pintle on a 2" or 2-1/2" shank-mounted plate, insert the 1/2" socket head cap screws (#3) from the back side of the plate through the pintle. Secure with 1/2" lock washers (#2) and hex nuts (#1) as shown.

Torque all four fasteners to 100 ft-lbs.

