



YEARS: 2012,2015-17

MAKE: HYUNDAI / GENESIS

MODEL: GENESIS 5.0 / G80

STYLE: SEDAN

**WARNING: NEVER EXCEED YOUR VEHICLE MANUFACTURER'S RECOMMENDED TOWING CAPACITY**  
 For more information log onto [www.curtmfg.com](http://www.curtmfg.com) & for helpful towing tips log onto [www.hitchinfo.com](http://www.hitchinfo.com)

**WEIGHT CARRYING:**  
 TRAILER WEIGHT: 3,500 LBS.  
 TONGUE WEIGHT: 350 LBS.

**WARNING:**  
 WE RECOMMEND THE USE OF 18050 STABILIZING STRAPS FOR ALL NON-TRAILER (WHEEL-LESS) LOADS. PLEASE SEE THE CURT CATALOG OR VISIT US ONLINE AT [WWW.CURTMFG.COM](http://WWW.CURTMFG.COM) FOR FURTHER INFORMATION.

**PRO INSTALL TIME: 30 MIN.**  
**NOVICE INSTALL TIME: 60 MIN.**

IF YOU ARE HESITANT TO UNDERTAKE THIS TASK ON YOUR OWN, CONTACT AN AUTHORIZED CURT INSTALLER FOR ADDITIONAL ASSISTANCE.

**INSTALLATION REQUIRES:**

		10mm 19mm 3/4"
POWER DRILL	RATCHET	SOCKET
DRILL BIT 17/32"	TORQUE WRENCH	AVIATION SHEARS
MARKER		

**INSTALLATION TIPS:**

- BEFORE YOU BEGIN INSTALLATION, READ ALL INSTRUCTIONS THOROUGHLY.
- TO EASE INSTALLATION, 2 PEOPLE MAY BE REQUIRED.
- USING PROPER TOOLS WILL GREATLY IMPROVE THE QUALITY OF THE INSTALL AND REDUCE THE TIME REQUIRED.
- NEED HELP OR HAVE SOME QUESTIONS? CALL TECHNICAL SUPPORT AT 800.798.0813

**LEVEL OF DIFFICULTY: EASY**

EASY	MODERATE	CHALLENGING
	TRIM HEAT SHIELD	
	DRILLING REQUIRED	
	FISHWIRE HARDWARE	
	LOWER EXHAUST	

**VEHICLE PHOTO:**



**REPRESENTATIVE PHOTO**

**HITCH ILLUSTRATION:**

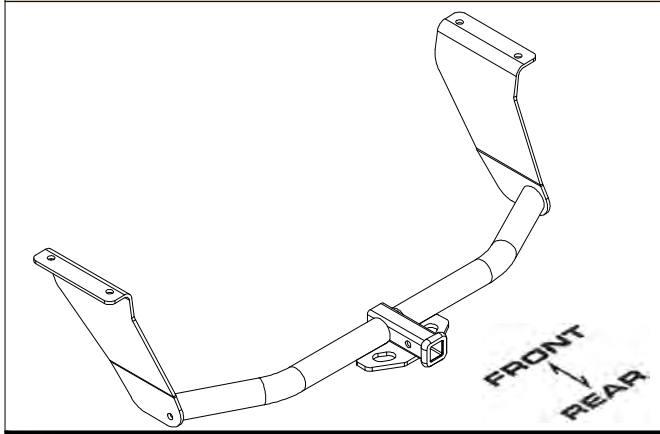

**MAKE SURE YOUR HITCH MATCHES**



SCAN FOR MORE INFO

**PERIODICALLY CHECK THIS RECEIVER HITCH TO ENSURE ALL FASTENERS ARE TIGHT AND ALL STRUCTURAL COMPONENTS ARE SOUND**

CURT Manufacturing LLC. warrants this product to be free of defects in material and/or workmanship at the time of retail purchase by the original purchaser. If the product is found to be defective, CURT Manufacturing LLC. may repair or replace the product at their option, when the product is returned, prepaid, with proof of purchase. Alteration to, misuse of, or improper installation of this product voids the warranty. CURT Manufacturing LLC.'s liability is limited to repair or replacement of products found to be defective, and specifically excludes liability for incidental or consequential loss or damage.

For more information log onto [www.curtmfg.com](http://www.curtmfg.com) , & for helpful towing tips log onto [www.hitchinfo.com](http://www.hitchinfo.com)

This product complies with safety specifications and requirements for connecting devices and towing systems of the state of New York, V.E.S.C.Regulation V-5 and SAE J684.

## INSTALLATION WALKTHROUGH:

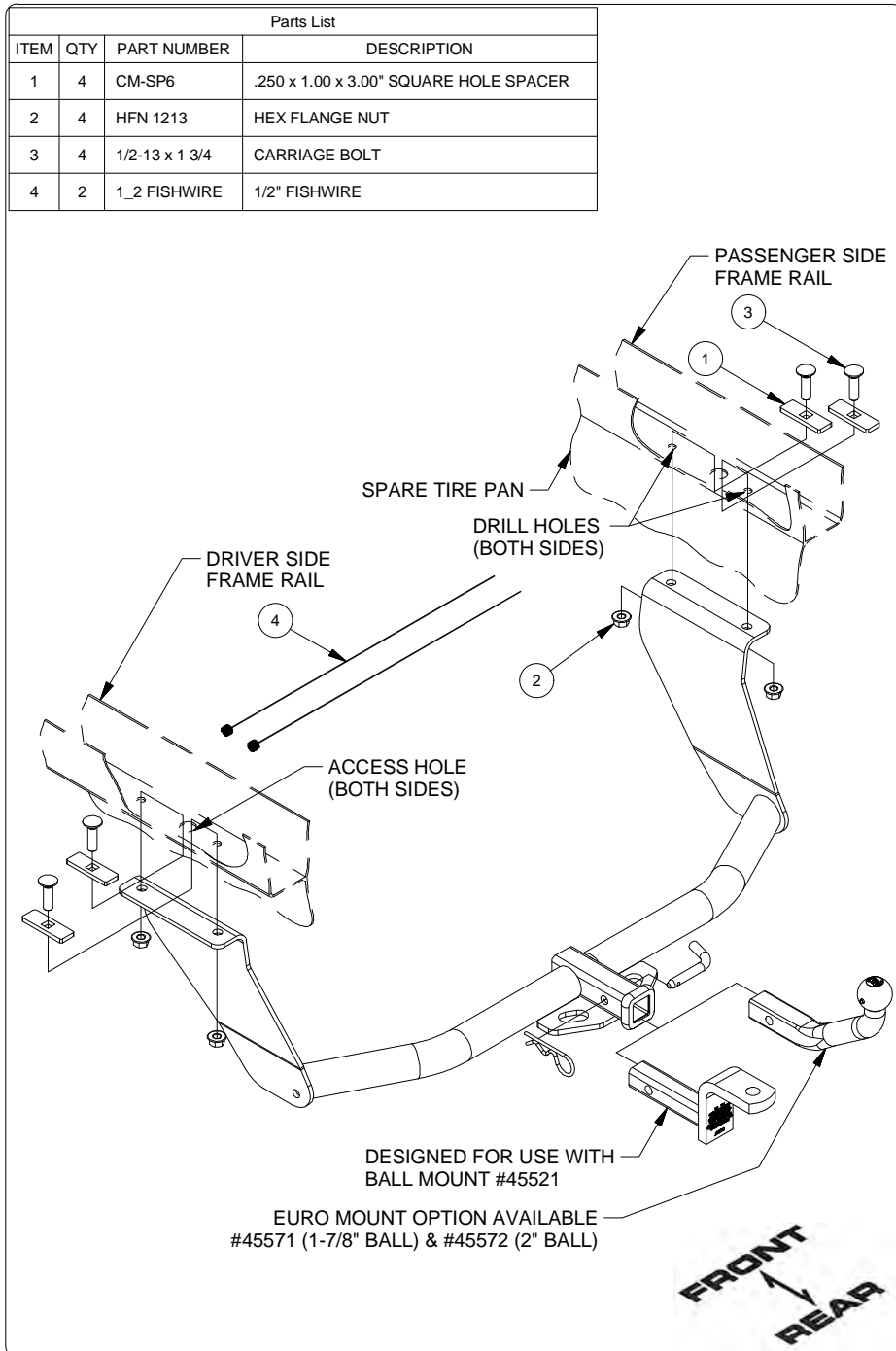

1. Remove (4) rear rubber exhaust isolators, and gently lower exhaust. Remove heat shields by removing (6) screws with a 10mm socket, both sides.

**NOTE:** On 2012 models remove (2) nuts with a 19mm socket in front of mufflers each side.



2. Clear away caulk from frame rail on both sides. Mark (1) hole 2.5" rearward of access hole centered along frame rail on each side. Raise hitch into position to use as template to mark out forwardmost holes. Lower hitch and drill (4) holes with 17/32" drill bit for 1/2" fasteners.

**NOTE:** All dimensions are approximate, confirm fit prior to drilling.



## INSTALLATION WALKTHROUGH:

3. Lower hitch and fishwire (2) bolts and (2) spacers into position on each side as shown in the Fishwire Diagram.

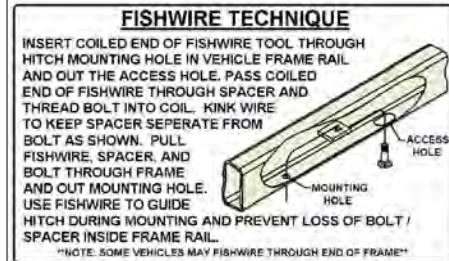

4. Raise hitch back into position and install supplied hex flange nuts. Torque all 1/2" fasteners to 110 lb-ft.



5. Modify heat shields as shown in trim diagram and reinstall with original fasteners. Raise exhaust and reinstall (4) rubber exhaust isolators removed in step (1).  
**NOTE:** On 2012 models bolt exhaust back together with original fasteners.

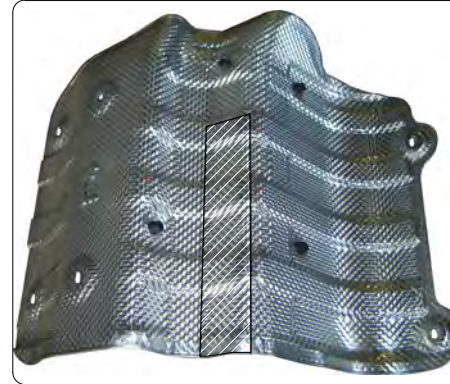

Installation complete.





## TOWING SAFETY INFORMATION

### Gross Trailer Weight / GTW

The Gross Trailer Weight is the weight of the trailer & cargo. Measure this by putting the fully loaded trailer on a vehicle scale.



### Tongue Weight / TW

The downward force that is exerted on the hitch ball by the coupler. The tongue weight will vary depending on where the load is positioned in relationship to the trailer axle(s). To measure the tongue weight, use either a commercial scale or a bathroom scale with the coupler at towing height. When using a bathroom scale with heavier tongue weights, use the method shown and multiply the scale reading by 3.

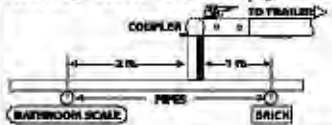

### Weight Carrying / WC

The total weight of both the trailer and the cargo inside. Never exceed the weight capacity of your trailer hitch.

### Weight Distribution / WD

Used to balance the weight of the cargo between the front and rear wheels throughout the trailer, allowing for better steering, braking, and level riding.



### Sway Control

A device used to reduce the lateral movements of the trailer that are caused by the wind. This works in conjunction with a weight distribution hitch. Do not use this on a class 1 or 2 hitch, or with surge brakes.

### How Much Can You Safely Tow?

TONGUE WEIGHT		TONGUE WEIGHT SHOULD BE ABOUT 10 TO 15 PERCENT OF THE GROSS TRAILER WEIGHT																		
TRAILER TYPE		CLASS 1					CLASS 2					CLASS 3								
Coupler	1100	1200	1300	1400	1500	1600														
	2100	2400	2700	3000	3300	3600	3900	4200	4500	4800										
	2800	3200	3600	4000	4400	4800	5200	5600	6000	6400										
<b>Refer to owner's manual for towing capabilities and limitations.</b>																				

### Ball Mount

The ball mount is placed inside the opening of the receiver hitch which is mounted to the vehicle. Make sure a hitch pin and clip is properly securing the ball mount to the receiver hitch before you begin towing.

• A: Rise. B: Drop. C: Hole Size. D: Length.

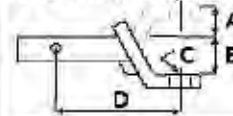

### Trailer Ball

The connection from the hitch to the trailer. There are many factors that determine the correct hitch ball:

- Number one is the hitch ball's gross trailer weight rating.
- The mounting platform must be at least 3/8" thick.
- The hole diameter must not be more than 1/16" larger than the threaded shank.
- Every time you tow, check the nut and lock washer to make sure they are fastened securely.
- A: Ball Dia. B: Shank Length. C: Shank Dia. D: Shank Rise.



### Coupler

The component that is placed over the trailer ball to connect the vehicle to the trailer. Be sure that the coupler size matches the size of the hitch ball and that the coupler handle is securely fastened. To determine what size hitch ball you need for your application you will need to know the size of coupler that is on the trailer. Be sure your coupler is properly adjusted to the ball you are using.

NOTE: For added security the use of safety devices such as Coupler Safety Pins and Locks is strongly recommended.

### Safety Chains

Safety chains are a requirement and should be crossed under the tongue of the trailer so that the tongue will not drop to the road if it becomes separated from the hitch. Always leave enough slack so you can turn. Never allow the safety chains to drag on the ground and never attach the chains to the bumper.

Trailer Classification: Safety Chain Breaking Force - Minimum

Class 1: 2,000 lbs. (8.9 kN)

Class 2: 3,500 lbs. (15.6 kN)

Class 3: 5,000 lbs. (22.2 kN)

The strength rating of each length of safety chain or its equivalent and its attachments shall be equal to or exceed in minimum breaking force the GVWR (Gross Vehicle Weight Rating) of the trailer.

### Electrical

Trailer lights, Electric Brakes, Break-away systems - Every time you tow, be sure to check that all components are working properly.

Wiring identification by color:



CURT DISCLAIMER: WIRING COLOR SHOWN WORK IN CONJUNCTION WITH CURT MANUFACTURING PRODUCTS.



12165

## HYUNDAI GENESIS 5.0 / GENESIS G80

1/5/2017

GROSS LOAD CAPACITY WHEN USED AS A WEIGHT CARRYING HITCH: 3,500 LBS. TRAILER WEIGHT &amp; 350 LBS. TONGUE WEIGHT.

WARNING: ALL NON-TRAILER LOADS APPLIED TO THIS PRODUCT MUST BE SUPPORTED BY 18050 STABILIZING STRAPS.

WARNING: \*\* FAILURE TO PROPERLY SUPPORT NON-TRAILER LOADS WILL VOID PRODUCT WARRANTY \*\*

WARNING: \*\*\* DO NOT EXCEED VEHICLE MANUFACTURER'S RECOMMENDED TOWING CAPACITY \*\*\*

FOR MORE INFORMATION LOG ONTO WWW.CURTMFG.COM & FOR HELPFUL TOWING TIPS LOG ONTO WWW.HITCHINFO.COM  
HAVING INSTALLATION QUESTIONS? CALL TECHNICAL SUPPORT AT 1-800-798-0813

Parts List				
ITEM	QTY	PART NUMBER	DESCRIPTION	
1	4	CM-SP6	.250 x 1.00 x 3.00" SQUARE HOLE SPACER	
2	4	HFN 1213	HEX FLANGE NUT	
3	4	1/2-13 x 1 3/4	CARRIAGE BOLT	
4	2	1_2 FISHWIRE	1/2" FISHWIRE	

## FISHWIRE TECHNIQUE

INSERT COILED END OF FISHWIRE TOOL THROUGH HITCH MOUNTING HOLE IN VEHICLE FRAME RAIL AND OUT THE ACCESS HOLE. PASS COILED END OF FISHWIRE THROUGH SPACER AND THREAD BOLT INTO COIL. KINK WIRE TO KEEP SPACER SEPARATE FROM BOLT AS SHOWN. PULL FISHWIRE, SPACER, AND BOLT THROUGH FRAME AND OUT MOUNTING HOLE. USE FISHWIRE TO GUIDE HITCH DURING MOUNTING AND PREVENT LOSS OF BOLT / SPACER INSIDE FRAME RAIL.

\*\*NOTE: SOME VEHICLES MAY FISHWIRE THROUGH END OF FRAME\*\*

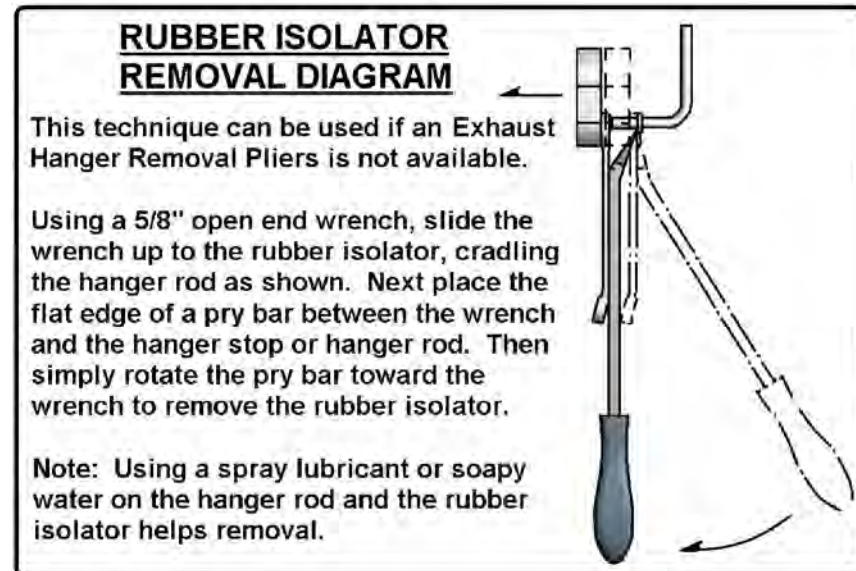
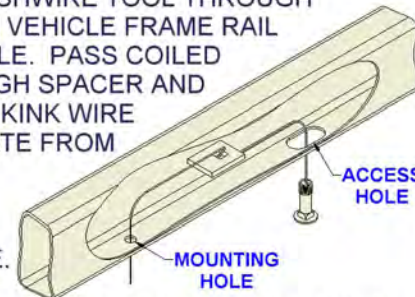

## TOOLS REQUIRED

DRILL W/ 17/32" DRILL BIT  
RATCHET  
10mm, 19mm SOCKET  
3/4" SOCKET  
TORQUE WRENCH  
AVIATOR SHEARS  
PENCIL / MARKER

## HEAT SHIELD DIAGRAM

REMOVE RUBBER ISOLATOR WITH SHEARS (BOTH SHIELDS)

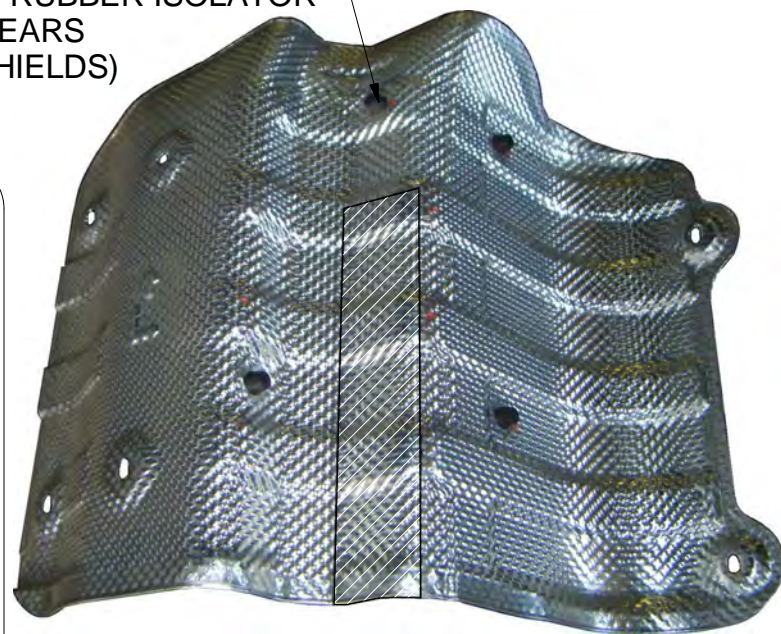

HITCH WEIGHT: 31 LBS.

## INSTALL TIME

PROFESSIONAL: 30 MINUTES

NOVICE (DIY): 60 MINUTES

## INSTALL NOTES:

- LOWER EXHAUST
- DRILLING REQUIRED
- FISHWIRE HARDWARE
- TRIM HEAT SHIELD
- 2 PERSON INSTALL RECOMENDED

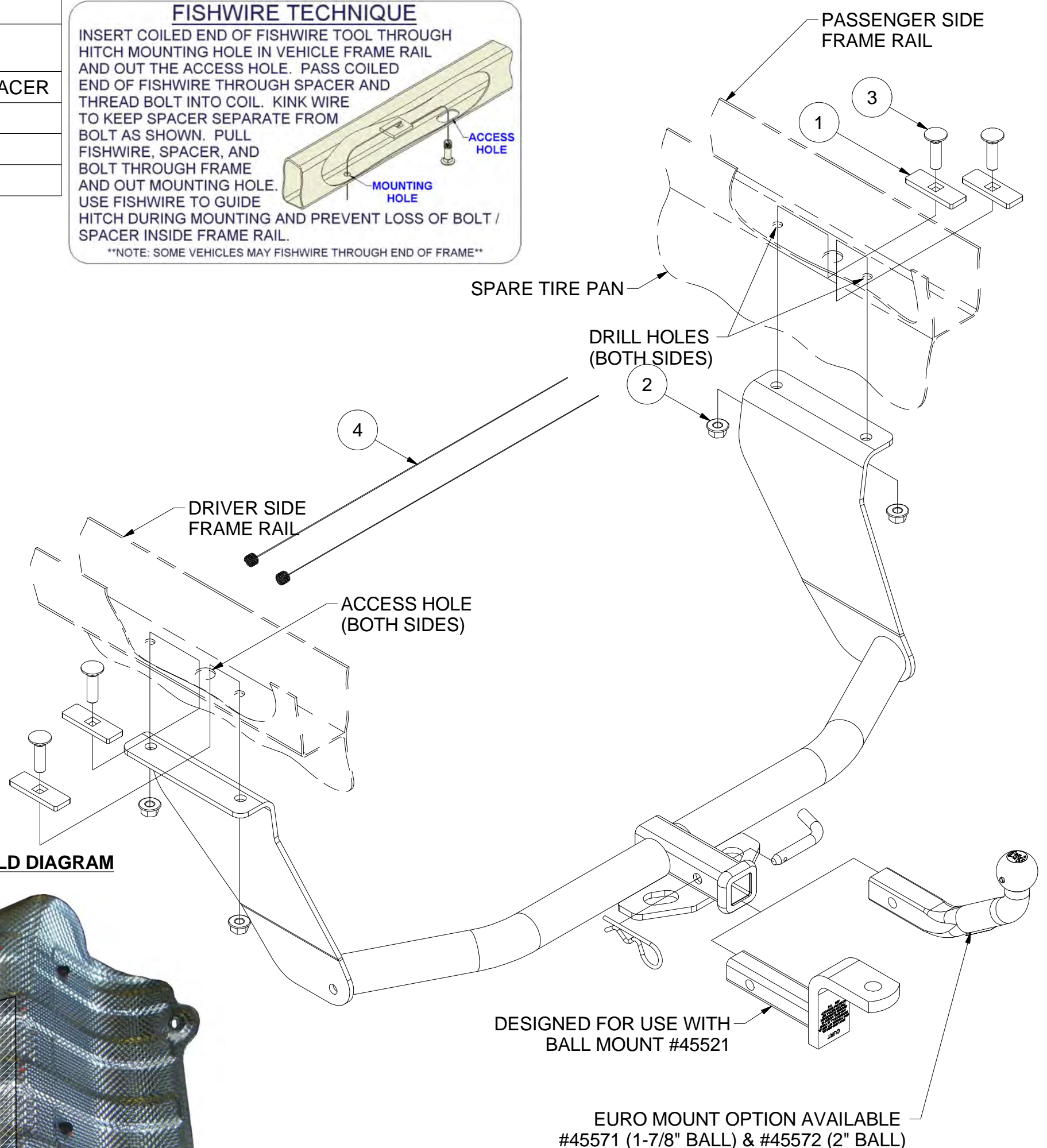

EURO MOUNT OPTION AVAILABLE #45571 (1-7/8" BALL) &amp; #45572 (2" BALL)

## INSTALLATION STEPS

- 1) Remove (4) rear rubber exhaust isolators, and gently lower exhaust. Remove heat shields by removing (6) screws with a 10mm socket, both sides.  
**NOTE:** On 2012 models remove (2) nuts with a 19mm socket in front of mufflers each side.
- 2) Clear away caulk from frame rail on both sides. Mark (1) hole 2.5" rearward of access hole centered along frame rail on each side. Raise hitch into position to use as template to mark out forwardmost hole. Lower hitch and drill (4) holes with 17/32" drill bit for 1/2" fasteners.  
**NOTE:** All dimensions are approximate, confirm fit prior to drilling.
- 3) Fishwire (2) bolts and (2) spacers into position on each side as shown in the Fishwire Diagram.
- 4) Raise hitch back into position and install supplied hex flange nuts. Torque all 1/2" fasteners to 110 lb-ft.
- 5) Modify heat shields as in trim diagram and reinstall with original fasteners. Raise exhaust and reinstall (4) rubber exhaust isolators removed in step (1).  
**NOTE:** On 2012 models bolt exhaust back together with original fasteners.

PERIODICALLY CHECK THIS RECEIVER HITCH TO ENSURE THAT ALL FASTENERS ARE TIGHT AND THAT ALL STRUCTURAL COMPONENTS ARE SOUND.



Scan for more information

CURT Manufacturing LLC., warrants this product to be free of defects in material and/or workmanship at the time of retail purchase by the original purchaser. If the product is found to be defective, CURT Manufacturing LLC., may repair or replace the product, at their option, when the product is returned, prepaid, with proof of purchase. Alteration to, misuse of, or improper installation of this product voids the warranty. CURT Manufacturing LLC.'s liability is limited to repair or replacement of products found to be defective, and specifically excludes liability for incidental or consequential loss or damage.

This product complies with safety specifications and requirements for connecting devices and towing systems of the state of New York, V.E.S.C.Regulation V-5 and SAE J684.